

CABLE MANAGEMENT

For the mechanical and electrical
services industry

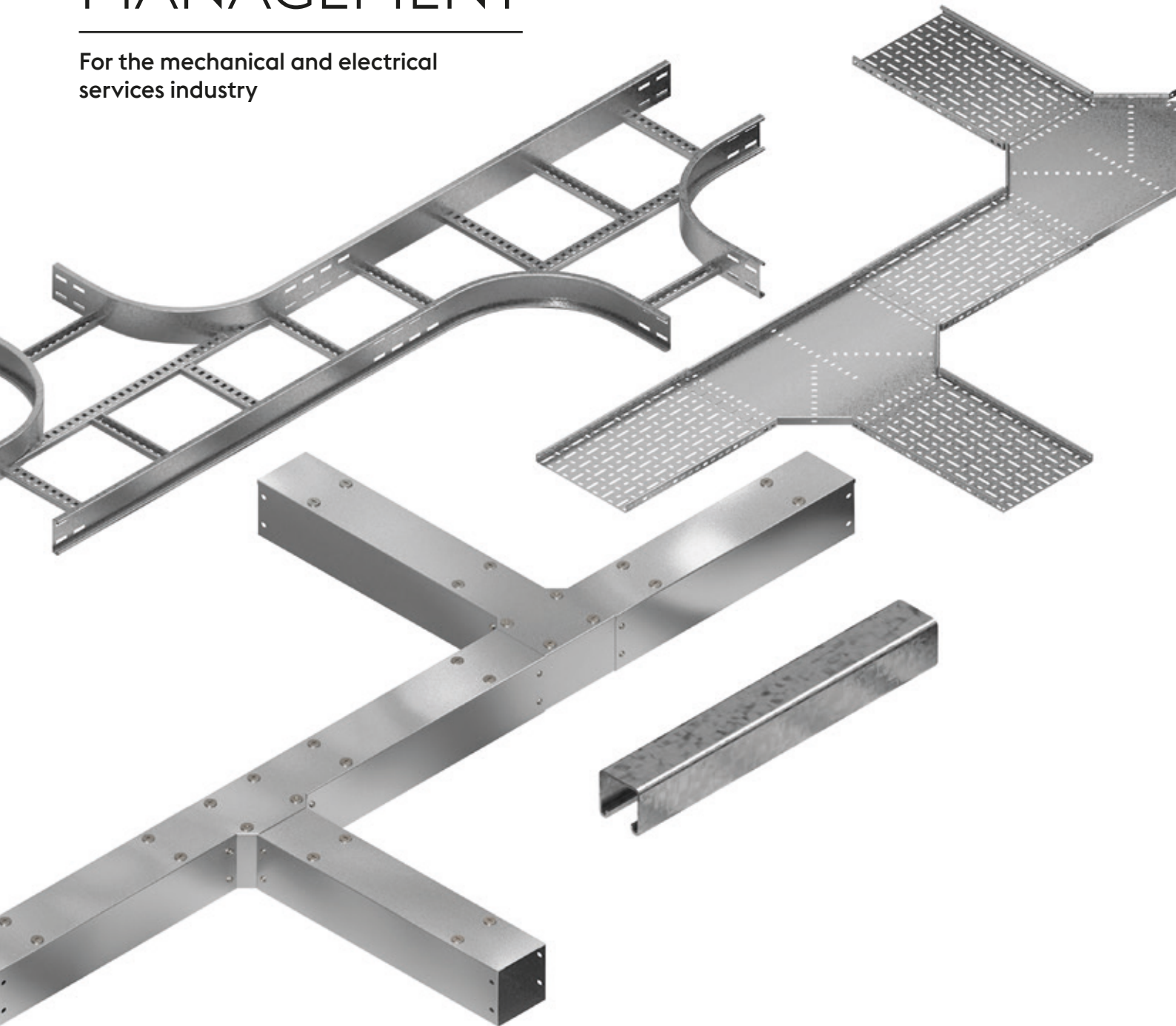

TRUST



Verified by Independent EPD authority



BSI Kitemark for Cable Management



Metsec Design Software



BES 6001 Accredited



London Underground approved supplier



ISO 14001 Accredited



BIM Level 2 Compliant



ISO 9001 Accredited



Fully registered supplier on Achilles UVDB



UKCA & CE Marked Products



Onsite Solutions



Public & Product Liability

CONTENTS

Commercial voestalpine Metsec plc	4	Cable Trunking Systems	82
Introducing Cable Management	5	Introducing SFS Load Bearing	84
Product Range Summary	6	Cable Tray Systems	86
The BSI Kitemark™	8	Standards	88
BES 6001	9	Product Footprint	92
IP4X	10	Straight Lengths & Couplers	93
Design and Collaboration	12	Flat Bends	94
Case Studies	14	Tees	95
The Quality You Expect, The Care You Need	18	Crossovers, Risers & Reducers	96
Our Heritage, This Is Our DNA	20	Accessories	104
Our Organisation, Company Structure	21	Cable Trunking Systems	106
BIM Design	22	Cable Trunking Systems	108
All the Hallmarks of Quality, Industry Standards	24	IP4X	112
Treading Carefully, Delivering Sustainability	26	Standards	114
Cable Ladder Systems	28	Standard Distribution Trunking	118
Cable Ladder Systems	30	Accessories & Lids	122
Post-galvanised & Stainless Steel Ladder	32	Compartmentalised Products	124
Post-galvanised & Stainless Steel Ladder Standards	34	Lighting Trunking	126
Accessory Footprint	38	Metal Framing Systems	128
Straight Lengths	39	Metal Framing Systems	130
Flat Bends	40	Standards	132
Tees & Crossovers	41	Load Tables	134
Reducers & Risers	42	Cantilever Arm Details	146
Covers	46	Channel, Fixings & Accessories	148
Accessories	52	Brackets	150
Pre-galvanised Ladder	56	Fasteners	154
Pre-galvanised Ladder Standards	58	Pre-fabrication	156
Accessory Footprint	64	Cable Management Brochure Updates	158
Straight Lengths	65		
Flat Bends	66		
Tees & Crossovers	67		
Reducers & Risers	68		
Covers	72		
Accessories	78		



INTRODUCING CABLE MANAGEMENT

voestalpine Metsec plc was the first company in the world to be awarded the BSI Kitemark™ for Cable Management. We manufacture a broad range of Cable Management products that includes cable ladder, cable tray, cable trunking, metal framing and rapid installation systems. All are complete systems with simple accessories, offering flexible design solutions.

We focus on adding value through expert design, precision manufacturing and on time, in-full delivery. Our aim is to provide excellent service, and quality products that deliver cost effective solutions to our customers.

- » Lightweight, cold-rolled galvanised steel sections
- » Able to be designed to bespoke customer requirements
- » All products are barcoded which allows for traceability throughout the manufacturing process
- » Comprehensive stocks are carried at all times
- » London Underground approved supplier
- » Fully registered as a supplier on the Achilles UVDB database for its products and services, achieving a 'Category A' rating for our Safety, Health, Environmental & Quality practices and procedures
- » Our design software DesignSPEC allows you to select and accurately specify the correct solutions for your project's Cable Management requirements

KEY BENEFITS

Quality

- » All products have been accredited with the BSI Kitemark™
- » CE Marked

Sustainability

- » Fully recyclable
- » Low carbon footprint

Value

- » A range of accessories manufactured by voestalpine Metsec plc for all our systems
- » Pre-fabrication service is also available for major contracts
- » Systems are fully supported by independent testing
- » Cut to length

PRODUCT RANGE SUMMARY

Manufacturing solutions

voestalpine Metsec plc manufactures a broad range of Cable Management products that includes cable tray, cable ladder, cable trunking, metal framing and rapid installation systems.

Centrally located within the West Midlands close to major motorway networks, Metsec is able to offer a national service through major electrical and mechanical distributors.

With over 10,000 m² of manufacturing and warehouse space, and state of the art equipment, a strong emphasis is placed on service, and a high level of 'on-time in-full' delivery performance is maintained.

Comprehensive stocks are carried at all times and replenished through lean manufacturing principles.

With the ever-increasing demand from clients for value added products and services, Metsec offers a comprehensive pre-fabrication facility that ranges from cut lengths of channel to bolted or welded frames both in 2D and 3D configuration. Cable tray, ladder and trunking can be pre-installed if required. This allows the contractor to schedule their requirements to overcome space and labour restrictions on site. Waste is also greatly reduced and site safety enhanced.

Significant cost savings can be achieved by opting for pre-fabrication off site and skilled electricians are released to do what they are best at.

Metsec also offers a full design service for its products and services to ensure the correct selection is made for the most cost effective solution. Where required, CAD drawings are produced to ensure a full understanding of the solution is achieved.



CABLE LADDER SYSTEMS

Metsec cable ladder systems are widely accepted due to their strength-to-weight ratio and simplicity of design. Easily installed and with a comprehensive range of accessories, Metsec cable ladder systems can be found in applications throughout the UK, Ireland and mainland Europe.



CABLE TRAY SYSTEMS

Metsec cable tray systems have been designed after considerable consultation with end users and installers to arrive at a final design that satisfies all of their requirements. Each cable tray range features a unique slotting pattern in the base and the return flange ranges have slotted sides. Additionally, each tray range has the same footprint to aid setting out when final loadings are not yet available.

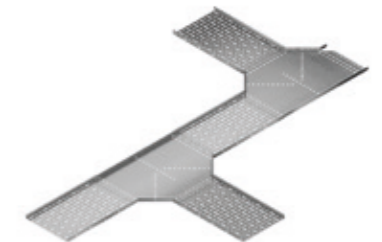

CABLE TRUNKING SYSTEMS

Metsec cable trunking systems are available as both standard distribution and lighting trunking. Manufactured on state of the art computer controlled equipment with a high level of automation, Metsec cable trunking is economically designed to provide competitive solutions.



METAL FRAMING SYSTEMS

Metsec offers the traditional channel system in a variety of profiles and gauges with a large range of fittings and fasteners. The fully tested system can be reliably used for a wide application base for the support of mechanical and electrical services.

A rapid installation version is also available with a unique channel profile and pre-assembled fittings with integral fixings. By using this product range, installation times are drastically reduced.

Both systems can be fully integrated for total flexibility.





METSEC FIRST TO ACHIEVE THE BSI KITEMARK™ FOR CABLE MANAGEMENT

Metsec chose BSI to test its entire product range, which includes cable trays, cable ladders, metal framing and cable trunking, to help highlight its commitment to quality and to provide customers with a 100 per cent guarantee that Metsec's products are of the highest standard. BSI piloted the new Cable Management scheme with Metsec, making it the first company to be certified to the BSI Kitemark™ for Cable Management to date. The rigorous and thorough testing process included dimensional, load, material conformity and electrical safety checks.

The certification further amplifies the company's dedication to quality, with Metsec's cable ladder and cable tray systems already having obtained third party CE markings supported by its previous certification to BS EN 61537 Cable Management.

Whilst not a compulsory certification for Cable Management products, the BSI Kitemark provides a guarantee that a product or service meets the applicable and appropriate British, European and International standards for quality, safety, performance and trust. In order to obtain the certification, all products must be independently tested and verified by BSI.

Being the first to pilot such a rigorous industry certification is a huge step for us at Metsec, and we're proud that our Cable Management products are now carrying the BSI Kitemark. We always strive to ensure that our products are market leaders when it comes to quality, so this third party certification, along with the inclusion of the CE marking on all of our products is a real landmark for us and the industry as a whole.

Malcolm Smith, Certification Technical Expert at BSI said: "By achieving the Kitemark, Metsec is assuring customers that their products are independently and robustly audited on a regular basis and that products are manufactured to an excellent standard of quality and safety, every time. The Kitemark is one of the UK's most trusted marks and will provide customers with peace of mind that they have insisted on the best products for their projects."

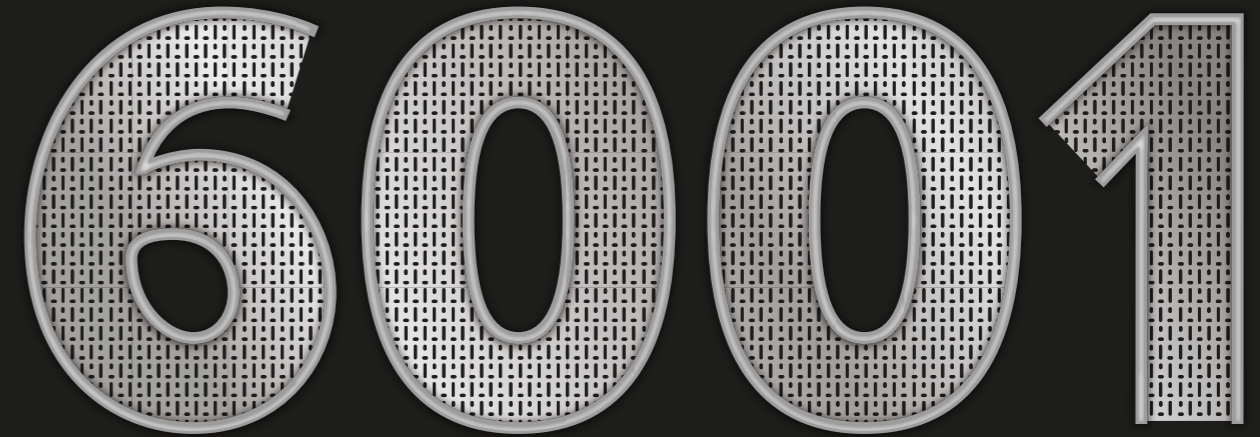

BES 6001

Metsec is one of only a handful of Cable Management suppliers with BES 6001 accreditation. This makes its products an attractive proposition for M&E consultants, specialist contractors, main contractors and their end clients when it comes to responsible procurement.

BES 6001 covers the responsible sourcing of construction products and suppliers must provide evidence of a holistic approach to the mining of raw materials, right through their manufacturing and processing phases. Such an accreditation is an important benefit for end clients and main contractors, whose focus is on driving environmental, social and corporate responsibility at the same time as upholding best practice.

The BES 6001 accreditation that we carry provides a proof point that customers are buying a high quality, audited product. This in turn offers reassurance that our product quality supports the duty of care responsibilities, main contractors and end clients have for health and safety on their sites, along with the important environmental and ethical sourcing of raw materials.

IP4X

CABLE CONTAINMENT COMPLIANCE

Satisfying the Wiring Regulations can become a cumbersome process when metallic electrical enclosures with a protection rating higher of IP30 are required.

Ensuring the safe performance of a trunking installation in line with legislative demands comes down to the correct specification for the application in question. For metal cable containment systems designed as of 2012, the first amendment to BS7671 "Requirements for electrical installations" demands that all single insulated, non-sheathed cables be contained in an enclosure that meets either IP4X or IPXXD rating. In accordance with BS EN 60529 + A2, both ratings aim to provide a specific degree of mechanical protection from the ingress of solid objects to prevent the disturbance of contained, unsheathed cables and potential short circuits, but they also serve to protect installers and service engineers from electrical accidents through unintended ingress of wire – a precautionary measure IP30 does not incorporate.

It is important to note that the two ingress protection (IP) ratings IP4X and IPXXD are not equally robust. The crux lies in the alphanumeric IP code, which classifies the dust-resistance and waterproofing of Cable Management trunking and containment systems. The numerals refer to the level of protection needed against the ingress of solid objects and water. Such protection is indicated by the first and second numeral respectively. It is worth considering, however, that the use of 'X' in any protection rating indicates that, for the range of products covered, protection is not required.

For example, IP4X specifies that protection against a 1.0mm probe is required and that there is no requirement for the protection from the ingress of water. Consequently, IP4X may not be watertight but it protects the cabling from ingress of debris or wire – or generally foreign objects that could all compromise the safety of the cabling within – tested with a 1mm diameter probe that will not penetrate any trunking.

In the case of IPXXD, by contrast, the gap resulting from adjoining trunking need not be protected from solid particle or liquid ingress altogether. Solely the letter 'D' appended to the code indicates that protection be provided against access to hazardous parts with wire. Even though physical contact may not be allowed to hazardous parts enclosed in the trunking during tests, the 1mm diameter probe shows that an IPXXD rated system remains penetrable to the degree of wire.

This goes to show that IPXXD as a protection rating does not make the same robust provision as IP4X, so the specification and installation of a system that complies with IP4X is a more reliable approach. To date, however, available solutions that achieve IP4X compliance have been limited to bespoke cable enclosures. These involve specially designed lengths and accessories that, more often than not, account for additional cost and command a longer lead time, stretching the contractor's installation programme because the required accessories and fittings are not available from distributors as standard stock.

The latest developments in the Cable Management market, however, may change the picture for specifiers, offering a more practical and, importantly, more economical route to IP4X compliance. Cable enclosures are seeing an addition to existing bespoke containment solutions in the form of standard trunking that uses off the shelf clips to deliver IP4X protection. While additional accessories are still required to enable the use of these clips in the bends of standard trunking, for the straight lengths, they can be fitted over the joint between two lids without the need for tailored accessories. This ensures that adjoining trunking stays tightly connected for years after the system installation.

Where a new cable containment solution is required, it is worth considering the benefits of a reduced lead time from the delivery of a standard trunking system that comes with simple, compatible clips. What is more, the use of standard parts ensures that the system retains its usual product footprint when it comes to upgrading the trunking to IP4X at a later point in time. Depending on the trunking in place, some existing installations will already be retrofittable.

By meeting IP4X, specifiers can give installers and those servicing the installation the confidence that the system meets the requirements of the Wiring Regulations in the most robust way. Therefore those responsible for the specification and installation of cable containment solutions should look to IP4X over IPXXD as the standard for best practice.

Manufacturers can support this process by making available products that effect IP4X compliance alongside ordinary Cable Management products in their range, with no special lead times, so M&E contractors can expect an IP4X compliant solution to arrive with the rest of their order and wholesalers need not rearrange stockholdings. In doing so, a supplier that provides standard product solutions adaptable to IP4X rating is able to make a positive contribution to the supply chain by easing lead times, reducing material costs and supporting a sustainable, safe and compliant Cable Management solution.

Ultimately, optimum specification should be the M&E contractor's overall driver. While the specification of IP4X may currently apply to a small number of projects only, advice on the ideal trunking solution is available from expert manufacturers, to meet the needs of the application, comply with the law and work within the end client's budget.

Metsec provides product solutions to IP4X as standard enabling us to make a positive contribution to the supply chain by easing lead times, reducing material costs and supporting a sustainable, safe and compliant Cable Management solution.

- » Fully accredited wide range of products from Metsec Cable Management, formerly Metstrut, includes BES 6001
- » Availability and great service are a direct result of our local manufacturing
- » Quality of our products supports health & safety demands
- » Technical support is drawn from expertise across Metsec and our parent company

DESIGN AND COLLABORATION FOR ON & OFF SITE SOLUTIONS

voestalpine Metsec plc manufacture premier Cable Management products to the highest quality, meeting the latest British and European standards. However, we also understand the need to provide technical and design support throughout the project programme from early tendering, through procurement and finally installation.

Metsec have a dedicated team of technical engineers that can visit sites and collaborate with the project engineers with regards to the design and installation of the Cable Management products. Often bespoke products are designed and manufactured to overcome installation issues on site, whilst maintaining the integrity of the system, meeting the specification and the relevant standards. As Metsec have the capability to manufacture all of its products from its West Midlands, UK facility, we can turnaround bespoke solutions to meet the installers requirements on short lead times. Products can also be manufactured ahead of the site programme at our manufacturing facility, thus reducing the risk of delays on site.

Metsec Cable Management sales team and technical engineers can work with the estimators, buyers and project teams to identify savings with regards to cost and installation times. Our market leading DesignSPEC3 software allows engineers to substitute lighter gauge profiles to value engineer the design of the support systems into cost effective solutions.

Metsec's site solutions will help eliminate hot work permits on site, provide products to the highest quality, reduce site programmes, reduce risk on site, reduce costs, all whilst complying with the specification and the latest British and European standards.

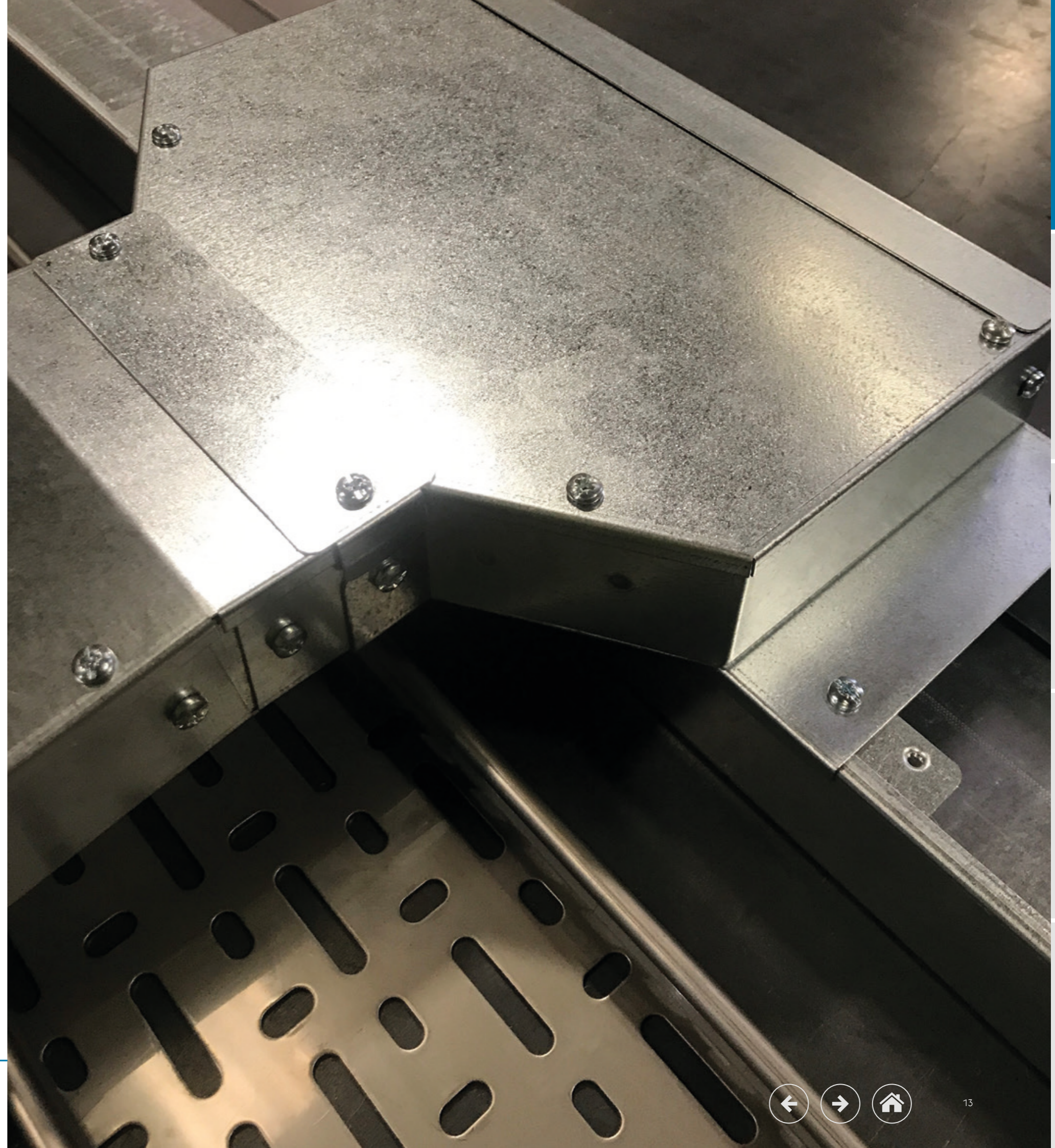

PROJECT: 5 BROADGATE

Metsec steps up with Cable Management for prestigious London office development

Challenge

- » Sustainability
- » Non standard products required for the project

Solution

- » voestalpine Metsec plc BES 6001 accreditation means the products are responsibly sourced, high quality and audited. This helped the project achieve BREEAM Excellent rating
- » Our engineers were able to design bespoke products and solution in collaboration with the site engineers to meet the needs of the project. These bespoke products and solutions were then manufactured effectively and efficiently to meet the site programme

Cold roll-formed steel specialist, voestalpine Metsec plc, has supported the construction of newly developed office space, 5 Broadgate in London through providing crucial Cable Management solutions.

The development opened in 2016 as office space for a global financial services company. Located in the heart of central London within close proximity of Liverpool Street Station, 5 Broadgate will boast 12-storeys of office space within its striking architectural design. Metsec were required to provide made to order cable containment, which were not simply stock designs to Marcoe Electrical, the electrical contractor.

While robust Cable Management is crucial within all modern office space, this was further amplified at 5 Broadgate due to a need for strong performing ventilation to prevent overheating equipment within the office. Having been involved at the beginning of planning stages through the provision of technical submissions, Metsec had the project knowledge and industry expertise to seamlessly step in and provide assurances to Marcoe Electrical, the electrical contractor on the project. 5 Broadgate has achieved a BREEAM Excellent rating, meaning that sustainability is also a must within the project, and Metsec's BES 6001 accreditation, covering responsible sourcing of products, ensures that this is achievable.

Jon Hillier, General Manager of Metsec's Cable Management division, commented:

"Metsec is one of only a handful of Cable Management suppliers with BES 6001 accreditation. Suppliers must provide evidence of a holistic approach from the mining of raw materials, right through to their manufacturing and processing phases. This is particularly important for clients and contractors driving environmental, social and corporate responsibility, while upholding best practice. Accreditation provides proof that customers are buying a high quality, audited product. It also gives reassurance that product quality supports the duty of care responsibilities main contractors and end clients have for health and safety on their sites."

Mark Crilley, Director at Marcoe Electrical, commented:

"We were very impressed with the way Metsec provided made to order, non-stock parts for the project. Their cable ladders and trays are very diverse and come in a wide range of sizes and load capacities, which allowed us a great level of flexibility when utilising the products. We have now specified Metsec products for our next Mace MEP Services Ltd project, Land Securities' major mixed use development Nova, Victoria that incorporates both commercial offices and residential apartments next to London Victoria Train Station."

Metsec's cable ladders and trays come in a wide range of sizes and load capacities, giving maximum flexibility to designers. They are also quick and easy to install, with simple connections between sections. The cable trunking is equally simple to install. Designed as complete systems, sections have integral connectors for all fittings as well as fixing bolts.



PROJECT: QUEENSFERRY CROSSING

Collaborative approach delivers UK's most connected bridge

Challenge

- » Extreme temperatures, thermal movement of the bridge
- » Non-standard lengths of containment were required to meet the requirement of the prefabricated modules and reduce installation time
- » Tight site programme

Solution

- » Thermal extension couplers were designed into the project with the support of the Metsec team
- » voestalpine Metsec plc re-programmed the mills to manufacture specified lengths of containment to meet tight timescales. Cable ladders were manufactured in 6.9 metre lengths and cable trays were manufactured in 3.5 metre lengths. This minimised waste and the amount of couplers required, reduced installation time and ensured an easy fit
- » We were able to meet the just in time capabilities needed to support the tight pre fabrication schedule

A landmark crossing

The landmark Queensferry Crossing Bridge in Scotland promises to be one of the most efficient, high performance bridges ever built. Designed to incorporate a complex array of utilities and communications equipment, a partnership between Cable Management specialist voestalpine Metsec plc, leading M&E fixings supplier in Scotland MEF and lead M&E contractor SES Engineering Services, part of Wates, has been critical in ensuring the delivery of the systems that will support the 2.7km road bridge and ensure its safe and efficient running for decades to come.

Opened 4th September 2017, the Queensferry Crossing forms the centrepiece of a major upgrade to the cross-Forth transport corridor in the east of Scotland. It will be the longest three-tower, cable-stayed bridge in the world and represents an investment of more than £1.3bn.

A major logistical project

The 250-tonne steel bridge sections arrived in Rosyth docks from China, where they were then prefabricated to incorporate all of the services and road surfaces. The Cable Management systems supplied by Metsec are prefabricated into 424 modules by SES and then installed into each of the 110 finished 750-tonne road section decks before they are taken out by barge onto the River Forth and then lifted by crane to connect to the span between the bridge towers.

All of the Cable Management products used had to be pre-approved by the bridge authority, Forth Crossing Bridge Constructors. Due to the extreme temperatures thermal extension couplers for Cable Management were designed into the project with the support of the Metsec team to help compensate for the movement of the bridge due to temperature fluctuations, wind and traffic.

A collaborative approach

Gordon Cullen, project manager at SES explains: "While we have a lot of experience in major infrastructure developments, the Queensferry Crossing is a once-in-a-lifetime project that demanded a highly collaborative approach to ensure we could meet and match the exact requirements to deliver all of the component parts of the bridge on time and in budget."

"MEF are part of the SES approved supply chain and they selected Metsec not only because they were the best from a commercial and quality point of view, but because they were able to supply the Cable Management systems we needed in special sizes, vitally important in terms of minimising waste and ensuring ease of fit. Particularly important was their willingness to adapt the units to minimise the number of joints required. Everything was spot on in terms of enabling the teams to fabricate and install each unit on schedule."

voestalpine Metsec plc supplied hot dip galvanised cable tray and cable ladders cut to special size lengths, the trays to 3.5m and the ladders to 6.9m. The finished modules assembled by SES will hold a complex array of water management and cabling needs from lighting and power to traffic management systems, security, fire alarms, radio communications, structural health monitoring and building monitoring, all designed to give optimal control over the management and performance of the bridge.

Cullen continues: "It's a highly complex installation that effectively acts as the 'brains' of the bridge, controlling everything from the timing of the lights to maintenance planning with a focus on optimising efficiency and communications not just on the bridge itself but on how it communicates with the traffic management systems that feed into it."

Reliability and quality

Alistair Fairweather, at MEF adds: "This is a fantastic project to work on and much of our involvement has been down to the support we have had from Metsec. We have worked with them for six or seven years and we knew that their involvement would be vital to us winning this contract. The sizes needed were not standard, but their UK-based manufacturing capabilities gave us the option to offer a flexible, high quality solution to SES that we knew Metsec could fulfil and deliver on time and in budget. In fact, flexibility was critical not just in securing the project but in meeting evolving requirements as the project has progressed over the past 12 to 18 months."



"We put a lot of faith in partnering with Metsec for what was one of the biggest projects we have ever worked on and it has really paid off. The reliability and the quality of service from the Metsec team has been as important as the quality of the product. The 55 micron hot dipped galvanised steel tray and ladder systems used will need to endure exposure to the elements for up to two years before being completely sealed in under the bridge, and the high quality of the product will contribute to the keeping the whole life costs of the project down."

Jon Hillier, General Manager at voestalpine Metsec plc Cable Management division added: "The Queensferry Crossing project was something we were keen to be involved in from the start. We knew we had the capability to re-programme our mill to allow us to manufacture the specified lengths of ladder and tray in away that would fit perfectly into the required modules. Working with MEF meant that we were also able to offer the just-in time capabilities needed to support the tight pre-fabrication scheduling for each deck for the bridge. We're thrilled to see the bridge completed, knowing that our products are effectively supporting the complex systems, that will drive the functionality of a bridge that is not only destined to be an infrastructure showpiece, but will help drive transport connectivity in the region for years to come."



THE QUALITY YOU EXPECT, THE CARE YOU NEED

At voestalpine Metsec plc, our customers receive our undivided attention from start to finish. For over 100 years we've helped customers to maintain their competitive edge by designing the best steel manufacturing and construction solutions on the market. In each of our products and services, we deliver high quality, added value solutions and have a reputation for short lead times.

Technical excellence

We offer outstanding technical excellence and expertise, providing absolute value through absolute quality.

Complete care

We care passionately about every detail of what we do, from our customer service and design approach, to our precision manufacturing and sustainability credentials.

Project management

Working closely with our customers and consultant engineers – we are an integral part of the project from start to finish.

Compliance

Our products meet the very latest legislation, are CE Marked and responsibly sourced in accordance with BES 6001. We were the first to operate an IMS compliant with the requirements of PAS 99.



OUR HERITAGE, THIS IS OUR DNA

At voestalpine Metsec plc, we're proud of both our past and our present. It gives our customers the best of everything.

Anchored in the traditional industry of the Black Country, Metsec has been at the forefront of UK manufacturing for over 85 years.

voestalpine Metsec is part of the voestalpine group, a globally leading technology group offering high-quality products and system solutions. voestalpine is the largest section rolling group in the world. voestalpine total sales are in excess of €13.6 billion annually.



OUR ORGANISATION, COMPANY STRUCTURE

- **voestalpine AG**

A globally leading steel and technology group with headquarters in Austria.

- **voestalpine – METAL FORMING DIVISION**

voestalpine's center of competence for highly refined sections, tubes and precision strip steel products as well as for ready-to-install system components made of pressed, stamped and roll-formed parts.

- **voestalpine METSEC PLC**

UK's largest specialist cold roll forming company, providing products for the construction and manufacturing industries.



- **Custom Roll Forming**



- **Cable Management**

Metsec Cable Management manufactures cable containment and support systems for the mechanical and electrical services industry.



Our 5 Divisions include:

1. **Custom Roll Forming** – From design concept to precision-fabricated metal profile.
2. **Dry Lining** – Non-load bearing partitioning, wall lining and ceiling solutions.
3. **Purlins** – Structural performance for roofs, walls and mezzanine floors.
4. **Framing (Metframe & SFS)** – Light Gauge Steel Framing Systems (SFS) for internal and external structural construction.
5. **Cable Management** – Cable containment and support systems.

BIM DESIGN

voestalpine Metsec plc is the first tier two organisation globally to be awarded the BSI Kitemark for its BIM capabilities and tier 2 designer and manufacturer complying with BIM Level 2 for Design and Construction in the UK accredited by the BSI. We aim to provide our customers with confidence in our ability to work collaboratively with others in the supply chain enhancing customer satisfaction and providing the following benefits:

- » Faster and efficient processes
- » Increased productivity
- » Reduced uncertainty – right first time philosophy
- » Controlled whole-life costs and environmental data
- » Avoidance and elimination of rework costs
- » Improved safety by working collaboratively within the supply chain
- » Comply with Government requirements for centrally funded projects
- » Reduction of waste
- » Collaborative working



We have the resources to fully detail the cold rolled steel elements of your project in either 2D or 3D environments using Revit allowing the voestalpine Metsec SFS to be detailed within a design team's model.

Alternatively, voestalpine Metsec Framing sections can now be downloaded from the voestalpine Metsec website for direct incorporation into your project BIM file. The individual 3D sections are available for download as Industry Foundation Classes (.ifc files) and Revit files (.rvt) so that they can be readily imported into your BIM model, regardless of the modelling software being used. The .ifc files all contain the necessary data to assist with the production of the Construction Operations Building Information Exchange (COBie) file required by clients at the end of a project.

In addition to the above voestalpine Metsec also offer:

- » A list of approved installers that your estimating/QS teams should be approaching for best prices
- » Free site inspections
- » UKCA and CE Marked product, which is a legal requirement for the SFS market

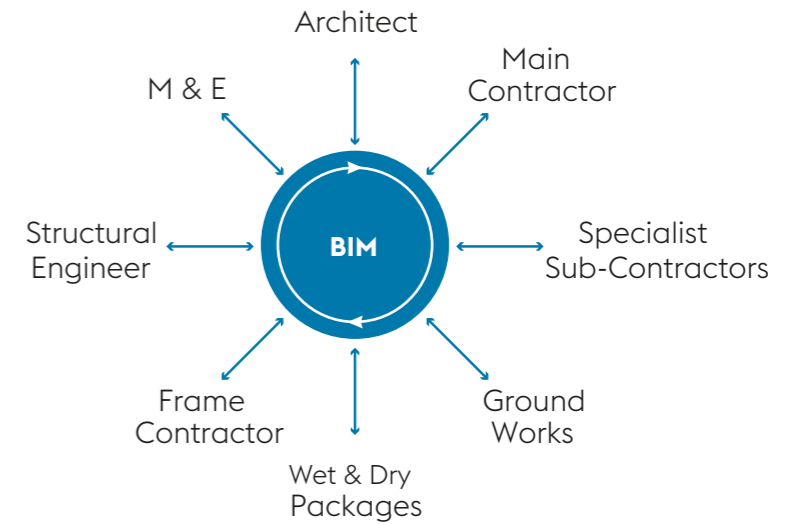
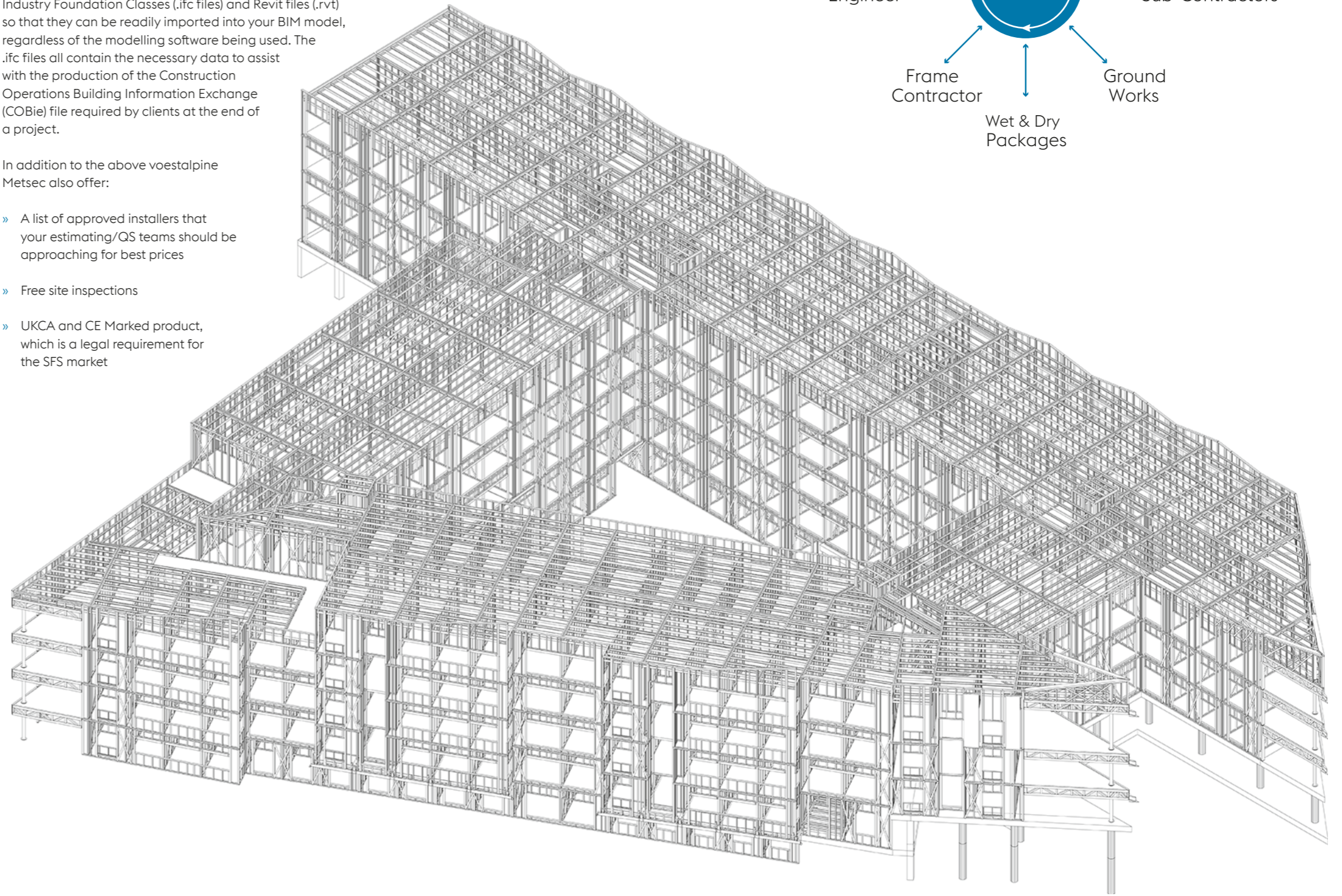

ALL THE HALLMARKS OF QUALITY, INDUSTRY STANDARDS

At voestalpine Metsec plc, we pride ourselves on delivering solutions fully in line with the latest legislation, regulation and industry standards. So whatever you specify, you can be assured of the quality of product you've purchased.

BS EN ISO 9001

Our BS EN ISO 9001 quality management certification assures our customers that we consistently provide products that meet both our customer and applicable regulatory requirements.

BS ISO 45001

BS ISO 45001 is the framework for occupational health and safety adopted by voestalpine Metsec plc, which sets out the minimum requirements for occupational health and safety management best practice in the workplace.

BSI Kitemark™ for Cable Management

We are the first company globally to achieve the BSI Kitemark™ for its Cable Management products. This highlights our commitment to quality and to provide customers with an assurance that Metsec's products are of the highest standard.

PAS 99

PAS 99 is the world's first specification for integrated management systems and provides us with one framework to manage all certified systems.

CE Marking

We were the first in our field to have our products CE Marked not only in design, but on the shop floor too. This ensures that all our bespoke products meet the requirements of the applicable EC directives. Similarly, our processes are certified up to EXC4, the highest standard available.



KM 635696

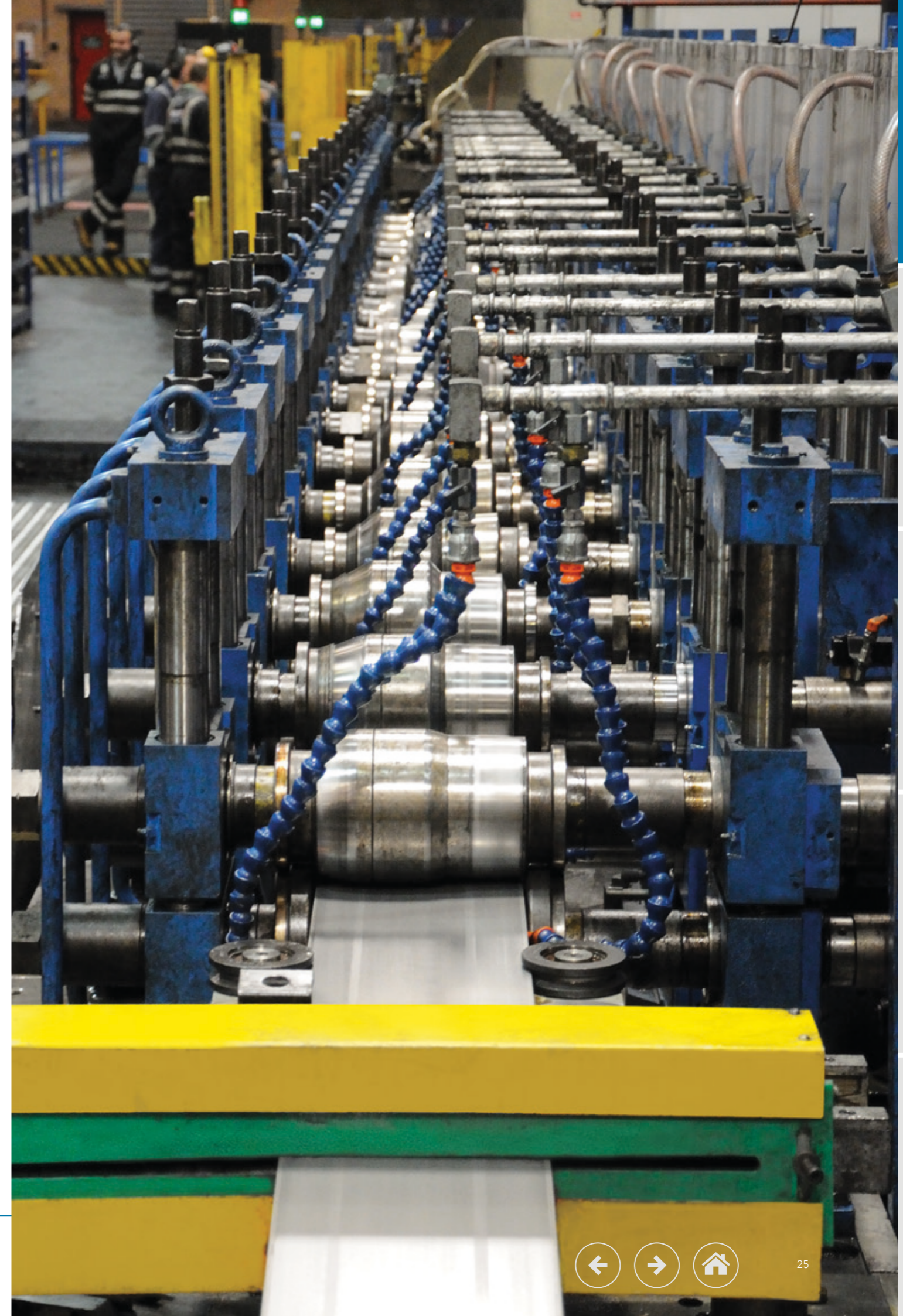

TREADING CAREFULLY, DELIVERING SUSTAINABILITY

We understand sustainability as a global issue.
To us it is a responsibility, not a choice.

Our company policy is to reduce our environmental and resource impacts everywhere that we can – from electricity and gas to water and waste-to-landfill.

We know that every efficiency counts. We also work hard to increase the fundamental sustainability of our steel systems in practice. Ninety four percent of all global steel can be recycled, while the lightness of our steel systems reduces the load on the substructure. The combined effect is to help reduce the carbon footprint of our projects in comparison to alternative methods.

In recognition of our ongoing efforts, voestalpine Metsec plc has received the following certifications:

BES 6001

The standard enables construction product manufacturers to ensure and then prove that their products have been made with constituent materials that have been responsibly sourced.

BS EN ISO 14001

BS EN ISO 14001 sets out the criteria for an environmental management system that can provide assurance to company management and employees as well as external stakeholders that environmental impact is being measured and improved.

BCSA STEEL CONSTRUCTION SUSTAINABILITY CHARTER

The objective of the Steel Construction Sustainability Charter is to develop steel's sustainability in terms of economic viability, social progress and environmental responsibility.



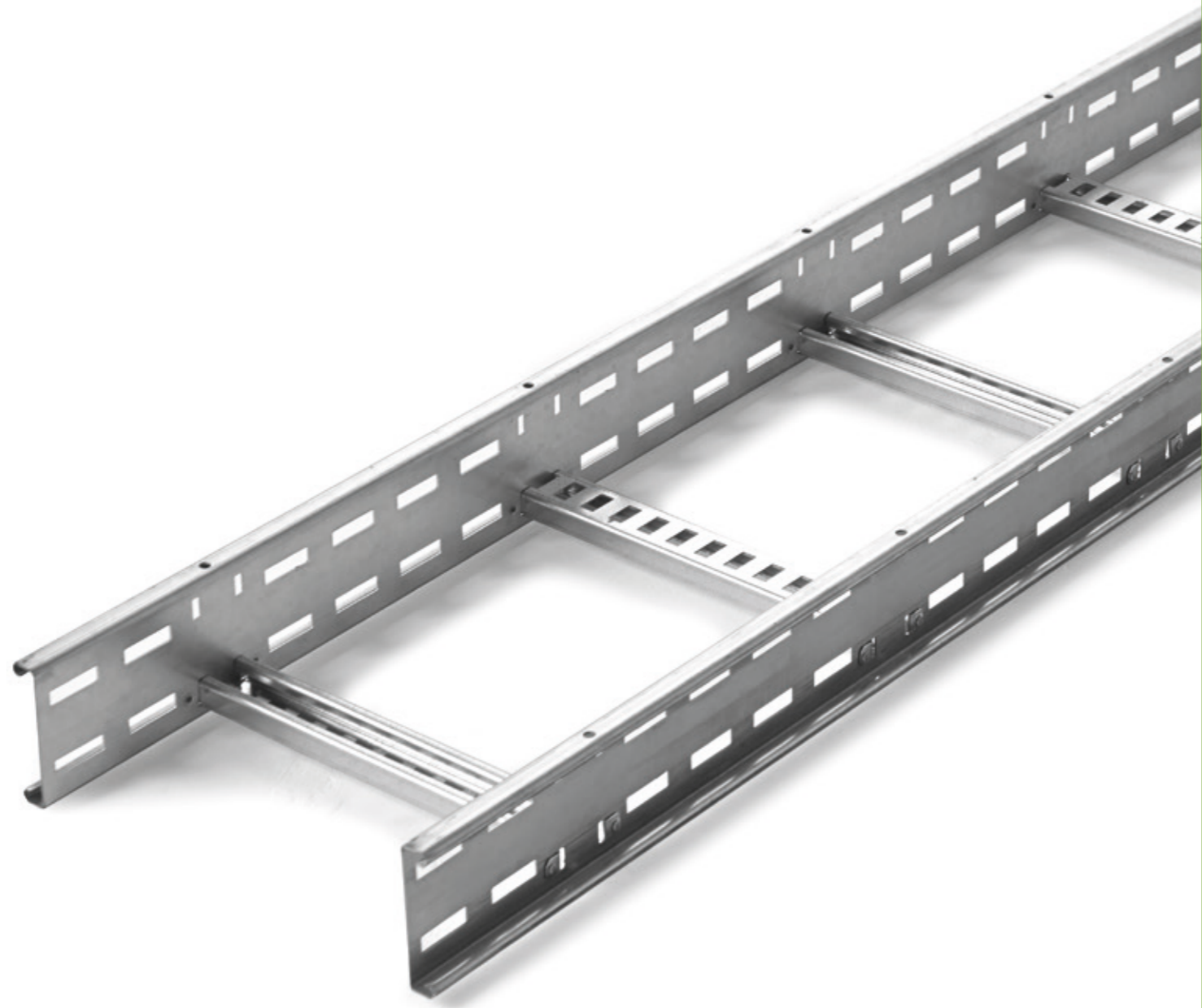

CABLE LADDER SYSTEMS

Post-galvanised and Stainless Steel Ladder
Pre-galvanised Ladder

CABLE LADDER SYSTEMS

Metsec cable ladder systems have been developed to provide cost effective solutions for the support of cables in a wide range of market sectors.

These sectors include:

- » Commercial
- » Education
- » Health
- » Oil and Gas
- » Petrochemical
- » Power Generation
- » Retail
- » Telecoms
- » Tunnels

The comprehensive Metsec cable ladder range consists of four systems commencing with the 50mm deep light duty, up to the 150mm deep extra heavy duty, all with a wide offering of accessories.

Slotted side rails whilst allowing easy connection to each other also allows site cut ladders to be connected generally without the need to drill. Additionally, Metsec cable ladders have an excellent strength to weight ratio providing a versatile approach to the support of cables.

For projects requiring long, straight runs of cable ladder, Metsec manufactures to order 6m lengths of straight ladder that speeds up the installation process and reduces the number of splice plates required for an even more cost effective solution. This would be particularly applicable to tunnel projects and large power stations or petrochemical installations.

Metsec is a leading manufacturer of cable ladder for not only the UK market, but also manufactures for export. European widths of cable ladder are available in increments of 100mm up to 900mm wide.

Rung configurations are traditionally with open faces alternately positioned up and down at 300mm centres. Cable ladders with rungs facing all down or all up are also available to order.

Offering comprehensive design solutions and flexible production through lean manufacturing principles, and with a very high on-time and in full delivery performance, Metsec has earned the reputation for its high level of service.

Development and testing

Metsec cable ladder systems have been developed in house and fully supported by independent testing.

Further verification testing has also been carried out under the requirements of BS EN 61537 – Cable Management – cable tray systems and cable ladder systems. These tests include: impact resistance, marking, connection of re-usable components, safe working load tests, electrical continuity, and performance of steel at extreme temperature ranges.



Load tables

Safe load tables are provided in a unique format for easy comparison and cost optimisation. Load tables assume an even distribution of load across the width of the ladder fixed in a horizontal plane, and that the loading is similar on at least two or more continuous spans. For non-uniform loads or spans/loadings outside the scope of the tables, please contact Metsec for advice.

Load kg/m	Type											
	50mm Deep			100mm Deep			125mm Deep			150mm Deep		
W	s	d	dp	s	d	dp	s	d	dp	s	d	dp
25	3.931	19.7	19.7	6.000	19.6	30.0	6.000	8.7	30.0	6.000	5.4	30.0
50	3.120	15.6	15.6	5.487	27.4	27.4	6.000	17.3	30.0	6.000	10.9	30.0
75	2.725	13.6	13.6	4.643	21.1	23.2	6.000	26.0	30.0	6.000	16.3	30.0
100	2.438	11.6	12.2	4.021	15.8	20.1	5.414	23.0	27.1	5.827	19.4	29.1
125	2.181	9.3	10.9	3.512	11.5	17.6	4.843	18.4	24.2	5.212	15.5	26.1
150	1.991	7.8	10.0	3.132	8.7	15.7	4.421	15.3	22.1	4.685	12.2	23.4
175	1.843	6.6	9.2	2.839	6.9	14.2	4.048	12.5	20.2	4.259	9.7	21.3
200	1.724	5.8	8.6	2.604	5.6	13.0	3.728	10.3	18.6	3.918	7.9	19.6
225	1.625	5.2	8.1	2.411	4.6	12.1	3.464	8.7	17.3	3.636	6.6	18.2
250	1.542	4.7	7.7	2.248	3.9	11.2	3.242	7.4	16.2	3.398	5.6	17.0
275	1.470	4.2	7.4	2.109	3.3	10.5	3.051	6.4	15.3	3.195	4.8	16.0
300	1.405	3.8	7.0	1.988	2.8	9.9	2.885	5.6	14.4	3.018	4.2	15.1

's' – maximum spacing of supports in metres
'd' – maximum deflection in end span in mm
'dp' – allowable deflection (span/200) in mm
'w' – safe working load in kg per linear metre

Loads not applicable to stainless steel, for stainless steel loads please consult the Technical Department for advice.

Example:

Load required = 100kg per linear metre

Options available:-

1. 50mm deep ladder will span up to a maximum of 2.438m with a deflection of 11.6mm
2. 100mm deep ladder will span up to a maximum of 4.021m with a deflection of 15.8mm
3. 125mm deep ladder will span up to a maximum of 5.414m with a deflection of 23.0mm
4. 150mm deep ladder will span up to a maximum of 5.827m with a deflection of 19.4mm



CABLE LADDER SYSTEMS

Post-galvanised and Stainless Steel Ladder

Metsec post-galvanised and stainless steel ladders are made using a welding process to ensure a strong and robust product. The welded products are then either galvanised or passivated, in the case of stainless steel, to ensure optimum corrosion performance. A full range of accessories are available as well as splice plates which come complete with M10 cup square bolts, shake proof washers and nuts.

When installing Metsec cable ladders, care should be taken to ensure the support is within 600mm of a joint. Accessories (e.g. bends, tees, crossovers etc.) should have adequate support. Additional support will be required for larger components.

Technical construction details

Whilst rungs are alternately reversed as standard, other rung orientations can be produced to order. Additionally alternative widths are also available to meet the requirements of the European markets.

Straight ladder

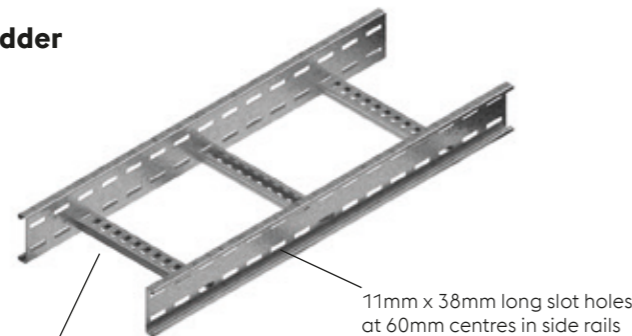

Rungs alternately reversed as standard at 300mm max. centres

Rung types

50, 100, 125 and 150mm deep ladder ranges rung type: 41mm x 21mm channel

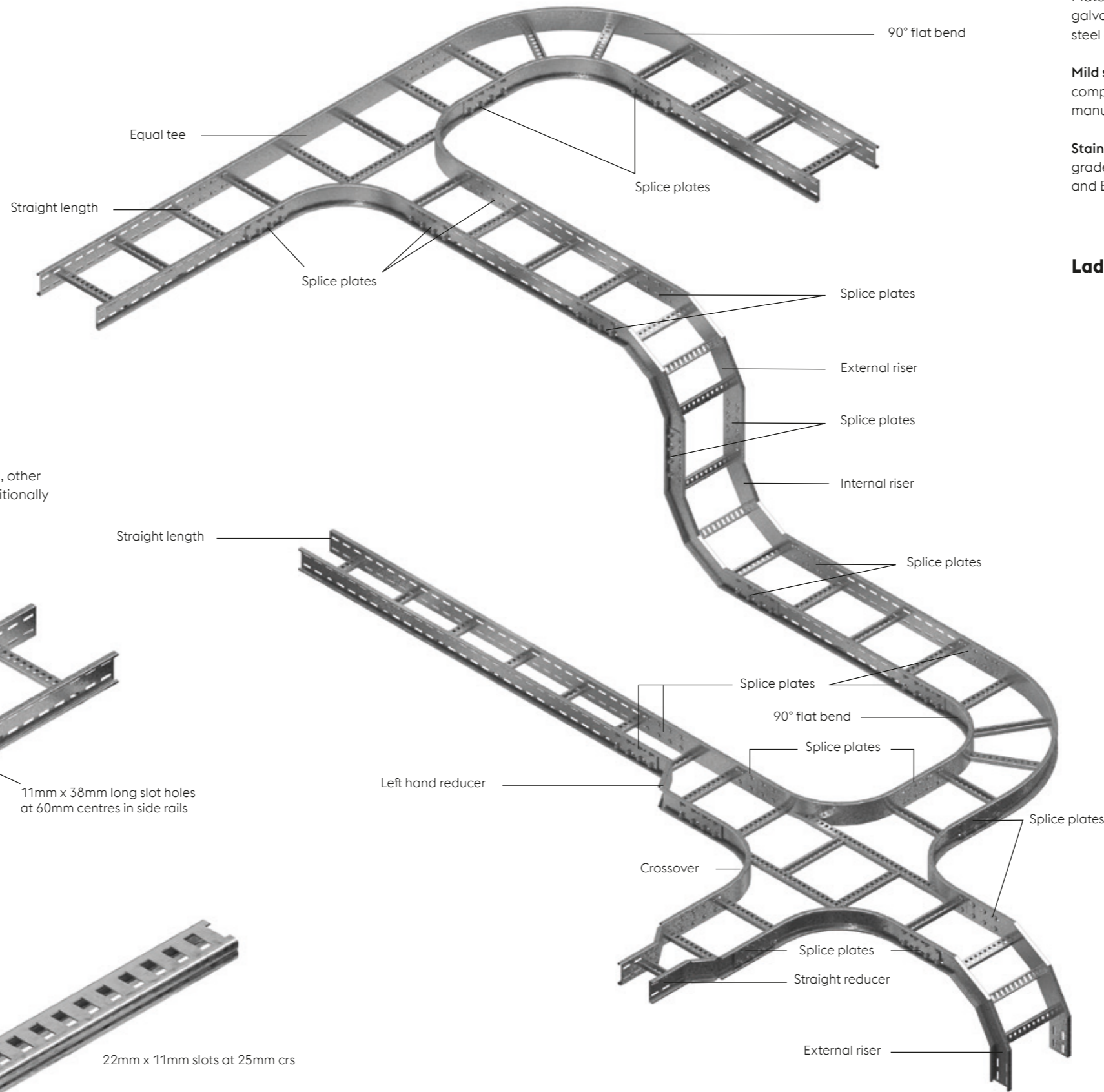
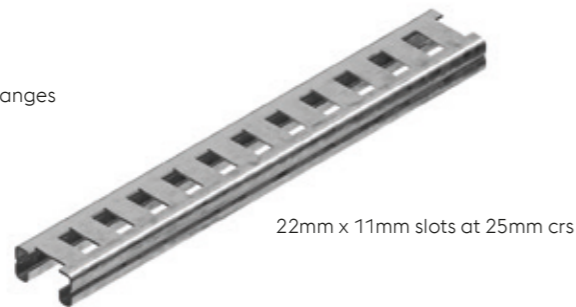

Materials and finishes

Materials and finishes available are mild steel hot dip galvanised after manufacture as standard and stainless steel grade 1.4404 (316L) to order.

Mild steel hot dip galvanised: manufactured from steel complying with BS EN 10025-2 and hot dip galvanised after manufacture to BS EN ISO 1461.

Stainless steel: manufactured from stainless steel grade 1.4404 (316L) complying with BS EN 10088-1 and BS EN 10088-2.

Ladder profiles

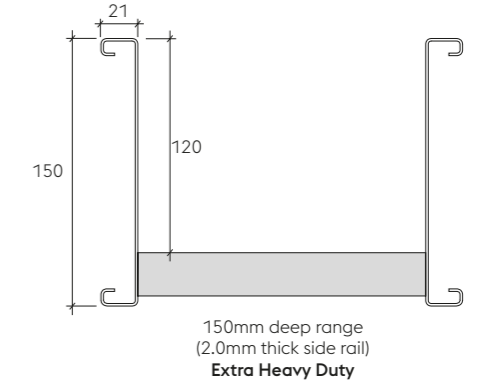
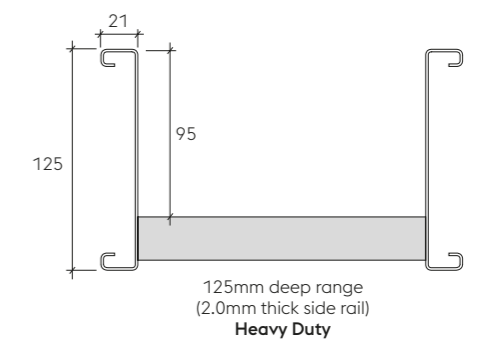
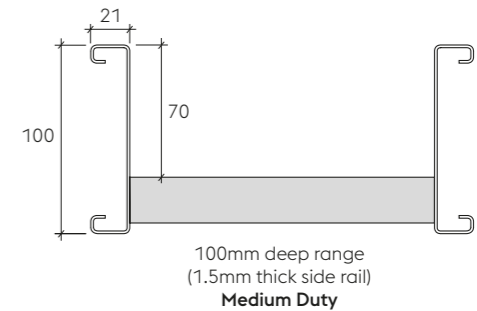
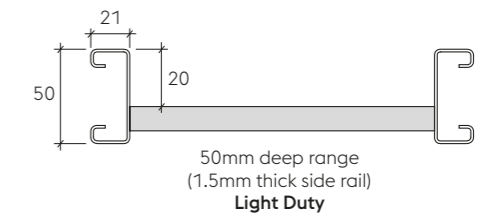

STANDARDS

Metsec cable ladder systems generally conform to BS EN 61537 Cable Management – cable tray systems and cable ladder systems

Information relating to compliance is detailed/highlighted within the following sections of the standard:

6 Classification

6.1	According to material	6.4	According to electrical conductivity
6.1.1	Metsec cable ladder systems are metallic system components	6.4.1	Metsec cable ladder systems are electrically conductive system components
6.2	According to resistance to flame propagation	6.5	According to resistance against corrosion
6.2.2	Metsec cable ladder systems are non-flame propagating system components	6.5.2	Metsec cable ladder systems are made of steel with metallic finishes or stainless steel
6.3	According to electrical continuity characteristics	(Resistance to corrosion is classified according to Table 1. and follow the relevant specification in Table 8, with compliance according to Table 7.)	
6.3.2	Metsec cable ladder systems have electrical continuity characteristics		

Table 1 – Classification for resistance against corrosion

Class	Reference – material and finish
0 (a)	None
1	Electroplated to a minimum thickness of 5 µm
2	Electroplated to a minimum thickness of 12 µm
3	Pre-galvanised to grade 275 to BS EN 10346
4	Pre-galvanised to grade 350 to EN 10346
5	Post-galvanised to a zinc mean coating thickness (minimum) of 45 µm according to BS EN ISO 1461 for zinc thickness only
6	Post-galvanised to a zinc mean coating thickness (minimum) of 55 µm according to ISO 1461 for zinc thickness only
7	Post-galvanised to a zinc mean coating thickness (minimum) of 70 µm according to ISO 1461 for zinc thickness only
8	Post-galvanised to a zinc mean coating thickness (minimum) of 85 µm according to ISO 1461 for zinc thickness only
9A	Stainless steel manufactured to ASTM: A 240/A 240M – 95a designation S30400 or EN 10088 grade 1 – 4301 without a post treatment (b)
9B	Stainless steel manufactured to ASTM: A 240/A 240M – 95a designation S31603 or EN 10088 grade 1 – 4404 without a post treatment (b)
9C	Stainless steel manufactured to ASTM: A 240/A 240M – 95a designation S30400 or EN 10088 grade 1 – 4301 with a post treatment (b)
9D	Stainless steel manufactured to ASTM: A 240/A 240M – 95a designation S31603 or EN 10088 grade 1 – 4404 with a post treatment (b)
(a)	For materials which have no declared corrosion resistance classification
(b)	The post-treatment process is used to improve the protection against crevice crack corrosion and the contamination by other steels

Table 7 – System component compliance and classification for resistance against corrosion

System component material and finishes	Classification according to	Compliance	Subclause for compliance check
Non-metallic	6.5.1	Declaration	14.2.1
Reference – zinc coating as in Table 1.	6.5.2 Table 1 classes 1 to 8	Declaration or measurement	14.2.2
Non-referenced zinc coating	6.5.2 Table 1 classes 1 to 8	By neutral salt spray test NSS	14.2.3
Reference – stainless steel as in Table 1.	6.5.2 Table 1 Class 9A to 9D	Declaration	14.2.2
Non-referenced stainless steel	Not classified	Declaration	None
Other metallic coatings	6.5.2 Table 1 Column 1 classes 1 to 8	By neutral salt spray test NSS	14.2.3
Aluminium alloys or other metals	6.5.3 Under consideration	Under consideration	14.2.4
Organic coatings	6.5.4 Under consideration	Under consideration	14.2.5

Table 8 – Zinc coating thickness of reference materials

Class	Minimum thickness	Minimum coating thickness as given in BS EN 10346	Mean coating thickness (minimum) to ISO 1461
	µm	µm	µm
0 (a)	-	-	-
1	5	-	-
2	12	-	-
3	-	13	-
4	-	17	-
5	-	-	45
6	-	-	55
7	-	-	70
8	-	-	85

a) As declared by the manufacturer or responsible vendor

6.6 According to temperature

6.6.1 Minimum temperature for the system components is given in Table 2.

6.6.2 Maximum temperature for the system components is given in Table 3.

6.8 According to the free base area of the cable ladder length as given in Table 5.**6.9 According to impact resistance**

6.9.5 System component offering impact resistance up to 50 J (as verified by testing in accordance with 10.9 Test for impact resistance.)

7 Marking and Documentation

7.1 Each system component is marked by a label. Labels used fully comply with the rubbing test. Boxed items are labelled on the packaging.

8 Dimensions**Key cross sectional dimensions for straight cable ladders**

Part No	External depth mm	Internal depth mm	External width mm	Internal width mm	X-sectional area mm ²
LSL050/0150#	50	20	192	150	3000
LSL050/0300#	50	20	342	300	6000
LSL050/0450#	50	20	492	450	9000
LSL100/0150#	100	70	192	150	10500
LSL100/0300#	100	70	342	300	21000
LSL100/0450#	100	70	492	450	31500
LSL100/0600#	100	70	642	600	42000
LSL100/0750#	100	70	792	750	52500
LSL100/0900#	100	70	942	900	63000
LSL125/0150#	125	95	192	150	14250
LSL125/0300#	125	95	342	300	28500
LSL125/0450#	125	95	492	450	42750
LSL125/0600#	125	95	642	600	57000
LSL125/0750#	125	95	792	750	71250
LSL125/0900#	125	95	942	900	85500
LSL150/0150#	150	120	192	150	18000
LSL150/0300#	150	120	342	300	36000
LSL150/0450#	150	120	492	450	54000
LSL150/0600#	150	120	642	600	72000
LSL150/0750#	150	120	792	750	90000
LSL150/0900#	150	120	942	900	108000

Table 2 – Minimum temperature classification

Minimum transport, storage installation and application temperature °C
+5
-5
-15
-20
-40
-50

Table 3 – Maximum temperature classification

Maximum transport, storage installation and application temperature °C
+40
+60
+90
+105
+120
+150

Table 5 – Free base area classification

Classification	Perforation in the free base area
X	Up to 80 %
Y	Over 80 % and up to 90 %
Z	More than 90 %

NB: Classification Z relates to IEC 60364-5-52 Subclause A.52.6.2 third paragraph

Minimum internal radius of fittings

Minimal internal radius of fittings available for the accommodation of cables is 300 mm.

9 Construction

- 9.1 Surfaces of system components which are likely to come into contact with cables during installation are inspected to ensure they shall not cause damage to the cables when installed correctly.
- 9.2 As with all metallic system components, care should be exercised that handling is in accordance with the relative COSHH regulations and gloves should be worn.
- 9.3 Screwed connections have been designed to withstand the mechanical stresses occurring during installations and normal use and will not cause damage to cables when correctly inserted. Screwed connections are in general ISO metric threads fully compliant to tests in accordance with 9.3.1 and 9.3.2 of the standard. Metsec cable ladder systems are usually assembled using M10 cup square bolts and hex nuts with lock washers for couplers etc tightened to a torque of 45N/m. Other connections require M10 hex bolts for clamps etc tightened to a torque of 25N/m.

10 Mechanical Properties

Cable ladder lengths have been tested generally in accordance with the standard under 10.2 and 10.3 for verification of the loading graphs. It should be noted that independent testing has been carried out to verify the structural performance of the cable ladders at the minimum and maximum temperature classifications for test conditions under 10.2.2.

All accessories e.g. bends, tees etc should be directly supported by a suitable support device or devices at appropriate positions.

CABLE LADDER SYSTEMS

Accessory Footprint

Cable ladder - accessory foot print standard radius is 300mm

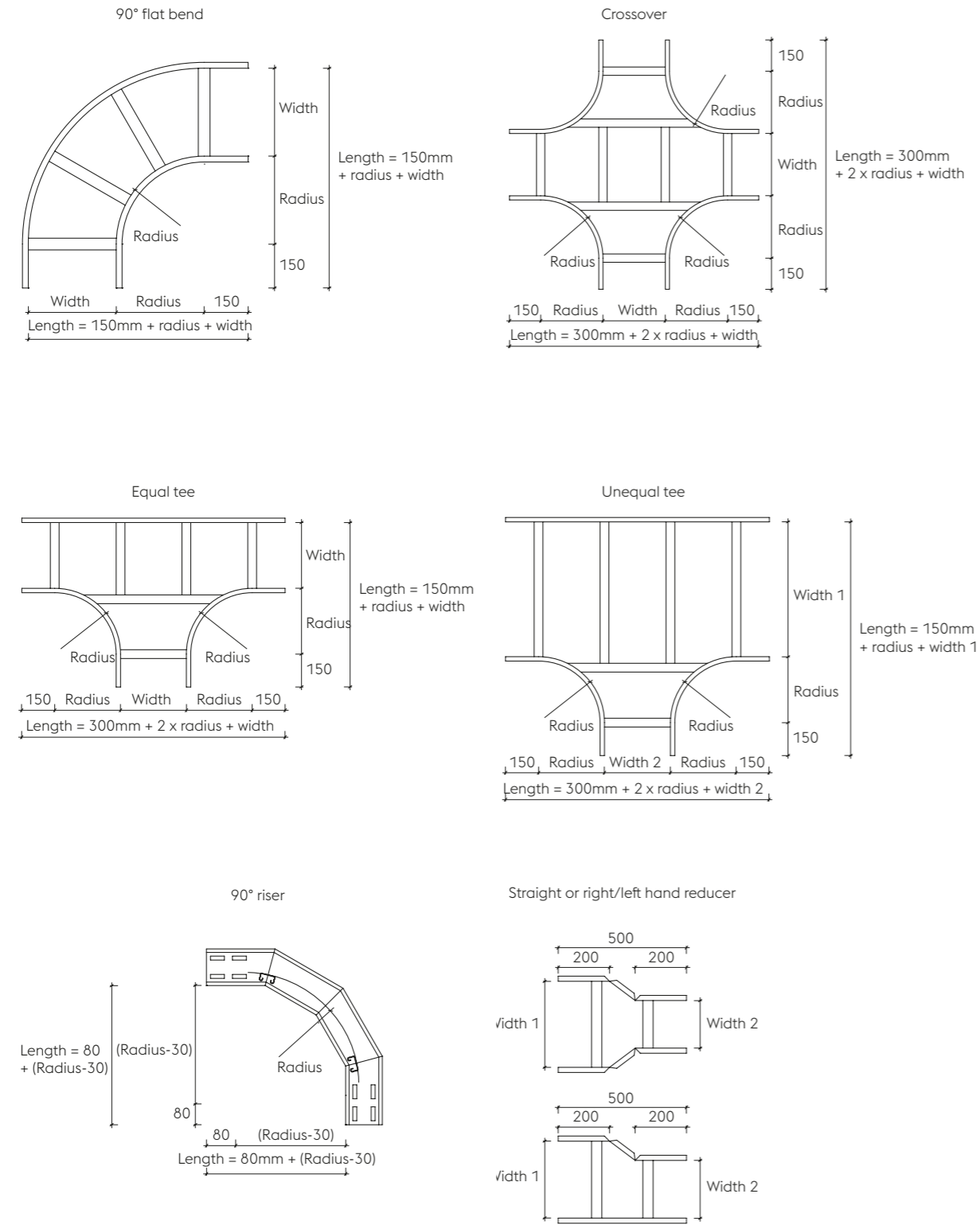

Footprints are identical for all ranges

Straight Lengths

Light duty - 50mm deep

Finish: hot dip galvanised = HDG, substitute SS within part number for stainless steel grade 1.4404 (316L)

Width mm	3m Long	6m Long
150	LSL050/0150HDG/3	N/A
300	LSL050/0300HDG/3	N/A
450	LSL050/0450HDG/3	N/A

Medium duty - 100mm deep

Finish: hot dip galvanised = HDG, substitute SS within part number for stainless steel grade 1.4404 (316L)

Width mm	3m Long	6m Long
150	LSL100/0150HDG/3	LSL100/0150HDG/6
300	LSL100/0300HDG/3	LSL100/0300HDG/6
450	LSL100/0450HDG/3	LSL100/0450HDG/6
600	LSL100/0600HDG/3	LSL100/0600HDG/6
750	LSL100/0750HDG/3	LSL100/0750HDG/6
900	LSL100/0900HDG/3	LSL100/0900HDG/6

Heavy duty - 125mm deep

Finish: hot dip galvanised = HDG, substitute SS within part number for stainless steel grade 1.4404 (316L)

Width mm	3m Long	6m Long
150	LSL125/0150HDG/3	LSL125/0150HDG/6
300	LSL125/0300HDG/3	LSL125/0300HDG/6
450	LSL125/0450HDG/3	LSL125/0450HDG/6
600	LSL125/0600HDG/3	LSL125/0600HDG/6
750	LSL125/0750HDG/3	LSL125/0750HDG/6
900	LSL125/0900HDG/3	LSL125/0900HDG/6

Extra heavy duty - 150mm deep

Finish: hot dip galvanised = HDG, substitute SS within part number for stainless steel grade 1.4404 (316L)

Width mm	3m Long	6m Long
150	LSL150/0150HDG/3	LSL150/0150HDG/6
300	LSL150/0300HDG/3	LSL150/0300HDG/6
450	LSL150/0450HDG/3	LSL150/0450HDG/6
600	LSL150/0600HDG/3	LSL150/0600HDG/6
750	LSL150/0750HDG/3	LSL150/0750HDG/6
900	LSL150/0900HDG/3	LSL150/0900HDG/6

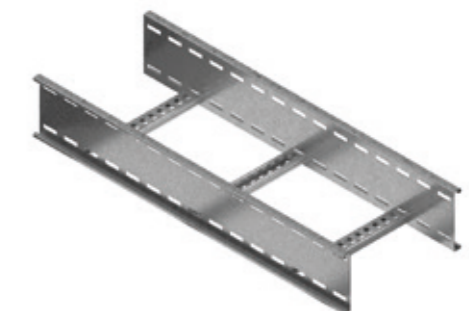
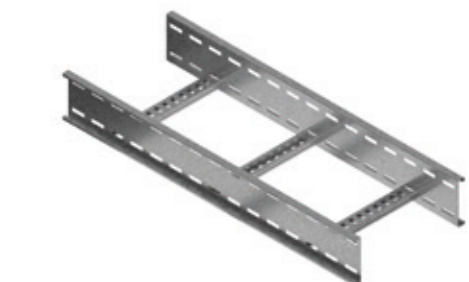
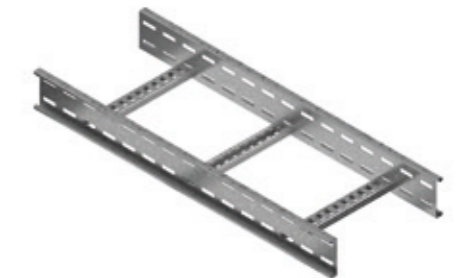

Flat Bends

90° flat bend

Standard radius 300mm = R300, other radii R450, R600, R750 and R900 (made to order).
Finish: hot dip galvanised = HDG, substitute SS within part number for stainless steel grade 1.4404 (316L)

Width mm	Light duty 50mm Deep	Medium duty 100mm Deep	Heavy duty 125mm Deep	Extra heavy duty 150mm Deep
150	LFB050/0150HDG/90R300	LFB100/0150HDG/90R300	LFB125/0150HDG/90R300	LFB150/0150HDG/90R300
300	LFB050/0300HDG/90R300	LFB100/0300HDG/90R300	LFB125/0300HDG/90R300	LFB150/0300HDG/90R300
450	LFB050/0450HDG/90R300	LFB100/0450HDG/90R300	LFB125/0450HDG/90R300	LFB150/0450HDG/90R300
600	N/A	LFB100/0600HDG/90R300	LFB125/0600HDG/90R300	LFB150/0600HDG/90R300
750	N/A	LFB100/0750HDG/90R300	LFB125/0750HDG/90R300	LFB150/0750HDG/90R300
900	N/A	LFB100/0900HDG/90R300	LFB125/0900HDG/90R300	LFB150/0900HDG/90R300



60° flat bend (made to order)

Standard radius 300mm = R300, other radii R450, R600, R750 and R900 (made to order).
Finish: hot dip galvanised = HDG, substitute SS within part number for stainless steel grade 1.4404 (316L)

Width mm	Light duty 50mm Deep	Medium duty 100mm Deep	Heavy duty 125mm Deep	Extra heavy duty 150mm Deep
150	LFB050/0150HDG/60R300	LFB100/0150HDG/60R300	LFB125/0150HDG/60R300	LFB150/0150HDG/60R300
300	LFB050/0300HDG/60R300	LFB100/0300HDG/60R300	LFB125/0300HDG/60R300	LFB150/0300HDG/60R300
450	LFB050/0450HDG/60R300	LFB100/0450HDG/60R300	LFB125/0450HDG/60R300	LFB150/0450HDG/60R300
600	N/A	LFB100/0600HDG/60R300	LFB125/0600HDG/60R300	LFB150/0600HDG/60R300
750	N/A	LFB100/0750HDG/60R300	LFB125/0750HDG/60R300	LFB150/0750HDG/60R300
900	N/A	LFB100/0900HDG/60R300	LFB125/0900HDG/60R300	LFB150/0900HDG/60R300



45° flat bend (made to order)

Standard radius 300mm = R300, other radii R450, R600, R750 and R900 (made to order).
Finish: hot dip galvanised = HDG, substitute SS within part number for stainless steel grade 1.4404 (316L)

Width mm	Light duty 50mm Deep	Medium duty 100mm Deep	Heavy duty 125mm Deep	Extra heavy duty 150mm Deep
150	LFB050/0150HDG/45R300	LFB100/0150HDG/45R300	LFB125/0150HDG/45R300	LFB150/0150HDG/45R300
300	LFB050/0300HDG/45R300	LFB100/0300HDG/45R300	LFB125/0300HDG/45R300	LFB150/0300HDG/45R300
450	LFB050/0450HDG/45R300	LFB100/0450HDG/45R300	LFB125/0450HDG/45R300	LFB150/0450HDG/45R300
600	N/A	LFB100/0600HDG/45R300	LFB125/0600HDG/45R300	LFB150/0600HDG/45R300
750	N/A	LFB100/0750HDG/45R300	LFB125/0750HDG/45R300	LFB150/0750HDG/45R300
900	N/A	LFB100/0900HDG/45R300	LFB125/0900HDG/45R300	LFB150/0900HDG/45R300



30° flat bend (made to order)

Standard radius 300mm = R300, other radii R450, R600, R750 and R900 (made to order).
Finish: hot dip galvanised = HDG, substitute SS within part number for stainless steel grade 1.4404 (316L)

Width mm	Light duty 50mm Deep	Medium duty 100mm Deep	Heavy duty 125mm Deep	Extra heavy duty 150mm Deep
150	LFB050/0150HDG/30R300	LFB100/0150HDG/30R300	LFB125/0150HDG/30R300	LFB150/0150HDG/30R300
300	LFB050/0300HDG/30R300	LFB100/0300HDG/30R300	LFB125/0300HDG/30R300	LFB150/0300HDG/30R300
450	LFB050/0450HDG/30R300	LFB100/0450HDG/30R300	LFB125/0450HDG/30R300	LFB150/0450HDG/30R300
600	N/A	LFB100/0600HDG/30R300	LFB125/0600HDG/30R300	LFB150/0600HDG/30R300
750	N/A	LFB100/0750HDG/30R300	LFB125/0750HDG/30R300	LFB150/0750HDG/30R300
900	N/A	LFB100/0900HDG/30R300	LFB125/0900HDG/30R300	LFB150/0900HDG/30R300



Tees & Crossovers

Equal tee

Standard radius 300mm = R300, other radii R450, R600, R750 and R900 (made to order).
Finish: hot dip galvanised = HDG, substitute SS within part number for stainless steel grade 1.4404 (316L)

Width mm	Light duty 50mm Deep	Medium duty 100mm Deep	Heavy duty 125mm Deep	Extra heavy duty 150mm Deep
150	LET050/0150HDGR300	LET100/0150HDGR300	LET125/0150HDGR300	LET150/0150HDGR300
300	LET050/0300HDGR300	LET100/0300HDGR300	LET125/0300HDGR300	LET150/0300HDGR300
450	LET050/0450HDGR300	LET100/0450HDGR300	LET125/0450HDGR300	LET150/0450HDGR300
600	N/A	LET100/0600HDGR300	LET125/0600HDGR300	LET150/0600HDGR300
750	N/A	LET100/0750HDGR300	LET125/0750HDGR300	LET150/0750HDGR300
900	N/A	LET100/0900HDGR300	LET125/0900HDGR300	LET150/0900HDGR300



Unequal tee (made to order)

Standard radius 300mm = R300, other radii R450, R600, R750 and R900.
Finish: hot dip galvanised = HDG, substitute SS within part number for stainless steel grade 1.4404 (316L)

How to generate the part number – LUT (depth)/W1/W2(finish) (radius)
Example – LUT100/0300/0150HDGR300

Table below shows a complete list of W1 and W2 combinations.

W1	W2
150	300, 450, 600, 750, 900
300	150, 450, 600, 750, 900
450	150, 300, 600, 750, 900
600	150, 300, 450, 750, 900
750	150, 300, 450, 600, 900
900	150, 300, 450, 600, 750



Crossovers (made to order)

Standard radius 300mm = R300, other radii R450, R600, R750 and R900 (made to order).
Finish: hot dip galvanised = HDG, substitute SS within part number for stainless steel grade 1.4404 (316L)

Width mm	Light duty 50mm Deep	Medium duty 100mm Deep	Heavy duty 125mm Deep	Extra heavy duty 150mm Deep
150	LCO050/0150HDGR300	LCO100/0150HDGR300	LCO125/0150HDGR300	LCO150/0150HDGR300
300	LCO050/0300HDGR300	LCO100/0300HDGR300	LCO125/0300HDGR300	LCO150/0300HDGR300
450	LCO050/0450HDGR300	LCO100/0450HDGR300	LCO125/0450HDGR300	LCO150/0450HDGR300
600	N/A	LCO100/0600HDGR300	LCO125/0600HDGR300	LCO150/0600HDGR300
750	N/A	LCO100/0750HDGR300	LCO125/0750HDGR300	LCO150/0750HDGR300
900	N/A	LCO100/0900HDGR300	LCO125/0900HDGR300	LCO150/0900HDGR300



Reducers

Straight reducer (made to order)

Finish: hot dip galvanised = HDG, substitute SS within part number for stainless steel grade 1.4404 (316L)

Width mm		Light duty 50mm Deep	Medium duty 100mm Deep	Heavy duty 125mm Deep	Extra heavy duty 150mm Deep
W1	W2				
300	150	LSR050/0300/0150HDG	LSR100/0300/0150HDG	LSR125/0300/0150HDG	LSR150/0300/0150HDG
450	150	LSR050/0450/0150HDG	LSR100/0450/0150HDG	LSR125/0450/0150HDG	LSR150/0450/0150HDG
600	150	N/A	LSR100/0600/0150HDG	LSR125/0600/0150HDG	LSR150/0600/0150HDG
750	150	N/A	LSR100/0750/0150HDG	LSR125/0750/0150HDG	LSR150/0750/0150HDG
900	150	N/A	LSR100/0900/0150HDG	LSR125/0900/0150HDG	LSR150/0900/0150HDG
450	300	LSR050/0450/0300HDG	LSR100/0450/0300HDG	LSR125/0450/0300HDG	LSR150/0450/0300HDG
600	300	N/A	LSR100/0600/0300HDG	LSR125/0600/0300HDG	LSR150/0600/0300HDG
750	300	N/A	LSR100/0750/0300HDG	LSR125/0750/0300HDG	LSR150/0750/0300HDG
900	300	N/A	LSR100/0900/0300HDG	LSR125/0900/0300HDG	LSR150/0900/0300HDG
600	450	N/A	LSR100/0600/0450HDG	LSR125/0600/0450HDG	LSR150/0600/0450HDG
750	450	N/A	LSR100/0750/0450HDG	LSR125/0750/0450HDG	LSR150/0750/0450HDG
900	450	N/A	LSR100/0900/0450HDG	LSR125/0900/0450HDG	LSR150/0900/0450HDG
750	600	N/A	LSR100/0750/0600HDG	LSR125/0750/0600HDG	LSR150/0750/0600HDG
900	600	N/A	LSR100/0900/0600HDG	LSR125/0900/0600HDG	LSR150/0900/0600HDG
900	750	N/A	LSR100/0900/0750HDG	LSR125/0900/0750HDG	LSR150/0900/0750HDG



Right hand reducer (made to order)

Finish: hot dip galvanised = HDG, substitute SS within part number for stainless steel grade 1.4404 (316L)

Width mm		Light duty 50mm Deep	Medium duty 100mm Deep	Heavy duty 125mm Deep	Extra heavy duty 150mm Deep
W1	W2				
300	150	LRR050/0300/0150HDG	LRR100/0300/0150HDG	LRR125/0300/0150HDG	LRR150/0300/0150HDG
450	150	LRR050/0450/0150HDG	LRR100/0450/0150HDG	LRR125/0450/0150HDG	LRR150/0450/0150HDG
600	150	N/A	LRR100/0600/0150HDG	LRR125/0600/0150HDG	LRR150/0600/0150HDG
750	150	N/A	LRR100/0750/0150HDG	LRR125/0750/0150HDG	LRR150/0750/0150HDG
900	150	N/A	LRR100/0900/0150HDG	LRR125/0900/0150HDG	LRR150/0900/0150HDG
450	300	LRR050/0450/0300HDG	LRR100/0450/0300HDG	LRR125/0450/0300HDG	LRR150/0450/0300HDG
600	300	N/A	LRR100/0600/0300HDG	LRR125/0600/0300HDG	LRR150/0600/0300HDG
750	300	N/A	LRR100/0750/0300HDG	LRR125/0750/0300HDG	LRR150/0750/0300HDG
900	300	N/A	LRR100/0900/0300HDG	LRR125/0900/0300HDG	LRR150/0900/0300HDG
600	450	N/A	LRR100/0600/0450HDG	LRR125/0600/0450HDG	LRR150/0600/0450HDG
750	450	N/A	LRR100/0750/0450HDG	LRR125/0750/0450HDG	LRR150/0750/0450HDG
900	450	N/A	LRR100/0900/0450HDG	LRR125/0900/0450HDG	LRR150/0900/0450HDG
750	600	N/A	LRR100/0750/0600HDG	LRR125/0750/0600HDG	LRR150/0750/0600HDG
900	600	N/A	LRR100/0900/0600HDG	LRR125/0900/0600HDG	LRR150/0900/0600HDG
900	750	N/A	LRR100/0900/0750HDG	LRR125/0900/0750HDG	LRR150/0900/0750HDG

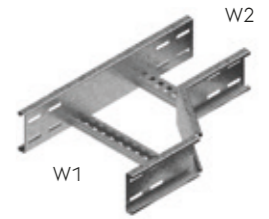

Left hand reducer (made to order)

Finish: hot dip galvanised = HDG, substitute SS within part number for stainless steel grade 1.4404 (316L)

Width mm		Light duty 50mm Deep	Medium duty 100mm Deep	Heavy duty 125mm Deep	Extra heavy duty 150mm Deep
W1	W2				
300	150	LLR050/0300/0150HDG	LLR100/0300/0150HDG	LLR125/0300/0150HDG	LLR150/0300/0150HDG
450	150	LLR050/0450/0150HDG	LLR100/0450/0150HDG	LLR125/0450/0150HDG	LLR150/0450/0150HDG
600	150	N/A	LLR100/0600/0150HDG	LLR125/0600/0150HDG	LLR150/0600/0150HDG
750	150	N/A	LLR100/0750/0150HDG	LLR125/0750/0150HDG	LLR150/0750/0150HDG
900	150	N/A	LLR100/0900/0150HDG	LLR125/0900/0150HDG	LLR150/0900/0150HDG
450	300	LLR050/0450/0300HDG	LLR100/0450/0300HDG	LLR125/0450/0300HDG	LLR150/0450/0300HDG
600	300	N/A	LLR100/0600/0300HDG	LLR125/0600/0300HDG	LLR150/0600/0300HDG
750	300	N/A	LLR100/0750/0300HDG	LLR125/0750/0300HDG	LLR150/0750/0300HDG
900	300	N/A	LLR100/0900/0300HDG	LLR125/0900/0300HDG	LLR150/0900/0300HDG
600	450	N/A	LLR100/0600/0450HDG	LLR125/0600/0450HDG	LLR150/0600/0450HDG
750	450	N/A	LLR100/0750/0450HDG	LLR125/0750/0450HDG	LLR150/0750/0450HDG
900	450	N/A	LLR100/0900/0450HDG	LLR125/0900/0450HDG	LLR150/0900/0450HDG
750	600	N/A	LLR100/0750/0600HDG	LLR125/0750/0600HDG	LLR150/0750/0600HDG
900	600	N/A	LLR100/0900/0600HDG	LLR125/0900/0600HDG	LLR150/0900/0600HDG
900	750	N/A	LLR100/0900/0750HDG	LLR125/0900/0750HDG	LLR150/0900/0750HDG



Risers

90° external riser

Standard radius 300mm = R300, other radii R450, R600, R750 and R900 (made to order).

Finish: hot dip galvanised = HDG, substitute SS within part number for stainless steel grade 1.4404 (316L)

Width mm	Light duty 50mm Deep	Medium duty 100mm Deep	Heavy duty 125mm Deep	Extra heavy duty 150mm Deep
150	LER050/0150HDG/90R300	LER100/0150HDG/90R300	LER125/0150HDG/90R300	LER150/0150HDG/90R300
300	LER050/0300HDG/90R300	LER100/0300HDG/90R300	LER125/0300HDG/90R300	LER150/0300HDG/90R300
450	LER050/0450HDG/90R300	LER100/0450HDG/90R300	LER125/0450HDG/90R300	LER150/0450HDG/90R300
600	N/A	LER100/0600HDG/90R300	LER125/0600HDG/90R300	LER150/0600HDG/90R300
750	N/A	LER100/0750HDG/90R300	LER125/0750HDG/90R300	LER150/0750HDG/90R300
900	N/A	LER100/0900HDG/90R300	LER125/0900HDG/90R300	LER150/0900HDG/90R300



60° external riser (made to order)

Standard radius 300mm = R300, other radii R450, R600, R750 and R900 (made to order).

Finish: hot dip galvanised = HDG, substitute SS within part number for stainless steel grade 1.4404 (316L)

Width mm	Light duty 50mm Deep	Medium duty 100mm Deep	Heavy duty 125mm Deep	Extra heavy duty 150mm Deep
150	LER050/0150HDG/60R300	LER100/0150HDG/60R300	LER125/0150HDG/60R300	LER150/0150HDG/60R300
300	LER050/0300HDG/60R300	LER100/0300HDG/60R300	LER125/0300HDG/60R300	LER150/0300HDG/60R300
450	LER050/0450HDG/60R300	LER100/0450HDG/60R300	LER125/0450HDG/60R300	LER150/0450HDG/60R300
600	N/A	LER100/0600HDG/60R300	LER125/0600HDG/60R300	LER150/0600HDG/60R300
750	N/A	LER100/0750HDG/60R300	LER125/0750HDG/60R300	LER150/0750HDG/60R300
900	N/A	LER100/0900HDG/60R300	LER125/0900HDG/60R300	LER150/0900HDG/60R300



45° external riser (made to order)

Standard radius 300mm = R300, other radii R450, R600, R750 and R900 (made to order).

Finish: hot dip galvanised = HDG, substitute SS within part number for stainless steel grade 1.4404 (316L)

Width mm	Light duty 50mm Deep	Medium duty 100mm Deep	Heavy duty 125mm Deep	Extra heavy duty 150mm Deep
150	LER050/0150HDG/45R300	LER100/0150HDG/45R300	LER125/0150HDG/45R300	LER150/0150HDG/45R300
300	LER050/0300HDG/45R300	LER100/0300HDG/45R300	LER125/0300HDG/45R300	LER150/0300HDG/45R300
450	LER050/0450HDG/45R300	LER100/0450HDG/45R300	LER125/0450HDG/45R300	LER150/0450HDG/45R300
600	N/A	LER100/0600HDG/45R300	LER125/0600HDG/45R300	LER150/0600HDG/45R300
750	N/A	LER100/0750HDG/45R300	LER125/0750HDG/45R300	LER150/0750HDG/45R300
900	N/A	LER100/0900HDG/45R300	LER125/0900HDG/45R300	LER150/0900HDG/45R300

**45° internal riser (made to order)**

Standard radius 300mm = R300, other radii R450, R600, R750 and R900 (made to order).

Finish: hot dip galvanised = HDG, substitute SS within part number for stainless steel grade 1.4404 (316L)

Width mm	Light duty 50mm Deep	Medium duty 100mm Deep	Heavy duty 125mm Deep	Extra heavy duty 150mm Deep
150	LIR050/0150HDG/45R300	LIR100/0150HDG/45R300	LIR125/0150HDG/45R300	LIR150/0150HDG/45R300
300	LIR050/0300HDG/45R300	LIR100/0300HDG/45R300	LIR125/0300HDG/45R300	LIR150/0300HDG/45R300
450	LIR050/0450HDG/45R300	LIR100/0450HDG/45R300	LIR125/0450HDG/45R300	LIR150/0450HDG/45R300
600	N/A	LIR100/0600HDG/45R300	LIR125/0600HDG/45R300	LIR150/0600HDG/45R300
750	N/A	LIR100/0750HDG/45R300	LIR125/0750HDG/45R300	LIR150/0750HDG/45R300
900	N/A	LIR100/0900HDG/45R300	LIR125/0900HDG/45R300	LIR150/0900HDG/45R300

**30° external riser (made to order)**

Standard radius 300mm = R300, other radii R450, R600, R750 and R900 (made to order).

Finish: hot dip galvanised = HDG, substitute SS within part number for stainless steel grade 1.4404 (316L)

Width mm	Light duty 50mm Deep	Medium duty 100mm Deep	Heavy duty 125mm Deep	Extra heavy duty 150mm Deep
150	LER050/0150HDG/30R300	LER100/0150HDG/30R300	LER125/0150HDG/30R300	LER150/0150HDG/30R300
300	LER050/0300HDG/30R300	LER100/0300HDG/30R300	LER125/0300HDG/30R300	LER150/0300HDG/30R300
450	LER050/0450HDG/30R300	LER100/0450HDG/30R300	LER125/0450HDG/30R300	LER150/0450HDG/30R300
600	N/A	LER100/0600HDG/30R300	LER125/0600HDG/30R300	LER150/0600HDG/30R300
750	N/A	LER100/0750HDG/30R300	LER125/0750HDG/30R300	LER150/0750HDG/30R300
900	N/A	LER100/0900HDG/30R300	LER125/0900HDG/30R300	LER150/0900HDG/30R300

**30° internal riser (made to order)**

Standard radius 300mm = R300, other radii R450, R600, R750 and R900 (made to order).

Finish: hot dip galvanised = HDG, substitute SS within part number for stainless steel grade 1.4404 (316L)

Width mm	Light duty 50mm Deep	Medium duty 100mm Deep	Heavy duty 125mm Deep	Extra heavy duty 150mm Deep
150	LIR050/0150HDG/30R300	LIR100/0150HDG/30R300	LIR125/0150HDG/30R300	LIR150/0150HDG/30R300
300	LIR050/0300HDG/30R300	LIR100/0300HDG/30R300	LIR125/0300HDG/30R300	LIR150/0300HDG/30R300
450	LIR050/0450HDG/30R300	LIR100/0450HDG/30R300	LIR125/0450HDG/30R300	LIR150/0450HDG/30R300
600	N/A	LIR100/0600HDG/30R300	LIR125/0600HDG/30R300	LIR150/0600HDG/30R300
750	N/A	LIR100/0750HDG/30R300	LIR125/0750HDG/30R300	LIR150/0750HDG/30R300
900	N/A	LIR100/0900HDG/30R300	LIR125/0900HDG/30R300	LIR150/0900HDG/30R300

**90° internal riser**

Standard radius 300mm = R300, other radii R450, R600, R750 and R900 (made to order).

Finish: hot dip galvanised = HDG, substitute SS within part number for stainless steel grade 1.4404 (316L)

Width mm	Light duty 50mm Deep	Medium duty 100mm Deep	Heavy duty 125mm Deep	Extra heavy duty 150mm Deep
150	LIR050/0150HDG/90R300	LIR100/0150HDG/90R300	LIR125/0150HDG/90R300	LIR150/0150HDG/90R300
300	LIR050/0300HDG/90R300	LIR100/0300HDG/90R300	LIR125/0300HDG/90R300	LIR150/0300HDG/90R300
450	LIR050/0450HDG/90R300	LIR100/0450HDG/90R300	LIR125/0450HDG/90R300	LIR150/0450HDG/90R300
600	N/A	LIR100/0600HDG/90R300	LIR125/0600HDG/90R300	LIR150/0600HDG/90R300
750	N/A	LIR100/0750HDG/90R300	LIR125/0750HDG/90R300	LIR150/0750HDG/90R300
900	N/A	LIR100/0900HDG/90R300	LIR125/0900HDG/90R300	LIR150/0900HDG/90R300

**Articulated riser (made to order)**

Finish: hot dip galvanised = HDG, substitute SS within part number for stainless steel grade 1.4404 (316L)

Width mm	Light duty 50mm Deep	Medium duty 100mm Deep	Heavy duty 125mm Deep	Extra heavy duty 150mm Deep
150	N/A	L/AR100/0150HDG	L/AR125/0150HDG	L/AR150/0150HDG
300	N/A	L/AR100/0300HDG	L/AR125/0300HDG	L/AR150/0300HDG
450	N/A	L/AR100/0450HDG	L/AR125/0450HDG	L/AR150/0450HDG
600	N/A	L/AR100/0600HDG	L/AR125/0600HDG	L/AR150/0600HDG
750	N/A	L/AR100/0750HDG	L/AR125/0750HDG	L/AR150/0750HDG
900	N/A	L/AR100/0900HDG	L/AR125/0900HDG	L/AR150/0900HDG

**60° internal riser (made to order)**

Standard radius 300mm = R300, other radii R450, R600, R750 and R900 (made to order).

Finish: hot dip galvanised = HDG, substitute SS within part number for stainless steel grade 1.4404 (316L)



Width mm	Light duty 50mm Deep	Medium duty 100mm Deep	Heavy duty 125mm Deep	Extra heavy duty 150mm Deep
150	LIR050/0150HDG/60R300	LIR100/0150HDG/60R300	LIR125/0150HDG/60R300	LIR150/0150HDG/60R300
300	LIR050/0300HDG/60R300	LIR100/0300HDG/60R300	LIR125/0300HDG/60R300	LIR150/0300HDG/60R300
450	LIR050/0450HDG/60R300	LIR100/0450HDG/60R300	LIR125/0450HDG/60R300	LIR150/0450HDG/60R300
600	N/A	LIR100/0600HDG/60R300	LIR125/0600HDG/60R300	LIR150/0600HDG/60R300
750	N/A	LIR100/0750HDG/60R300	LIR125/0750HDG/60R300	LIR150/0750HDG/60R300
900	N/A	LIR100/0900HDG/60R300	LIR125/0900HDG/60R300	LIR150/0900HDG/60R300



Covers

Straight length covers – 1.5mm long (made to order)

Finish: hot dip galvanised = HDG, substitute SS within part number for stainless steel grade 1.4404 (316L)
 Standard closed covers = C, ventilated cover = CV
 Includes fixing clamps and fasteners, 2 covers required for 3m ladder, 4 covers for 6m ladder

Width mm		Extra fixing clamps Pack of 10 (includes fasteners)	
150	LSLC/0150HDG/1.5	Closed cover clip	
300	LSLC/0300HDG/1.5	L/CCC	
450	LSLC/0450HDG/1.5		
600	LSLC/0600HDG/1.5	Ventilated cover clip	
750	LSLC/0750HDG/1.5		
900	LSLC/0900HDG/1.5	L/CCV	



90° flat bend covers (made to order)

Standard radius 300mm = R300, other radii R450, R600, R750 and R900 (made to order).
 Finish: hot dip galvanised = HDG, substitute SS within part number for stainless steel grade 1.4404 (316L)
 Standard closed covers = C, ventilated cover = CV
 Includes fixing clamps and fasteners

Width mm	
150	LFBC/0150HDG/90R300
300	LFBC/0300HDG/90R300
450	LFBC/0450HDG/90R300
600	LFBC/0600HDG/90R300
750	LFBC/0750HDG/90R300
900	LFBC/0900HDG/90R300



60° flat bend covers (made to order)

Standard radius 300mm = R300, other radii R450, R600, R750 and R900 (made to order).
 Finish: hot dip galvanised = HDG, substitute SS within part number for stainless steel grade 1.4404 (316L)
 Standard closed covers = C, ventilated cover = CV
 Includes fixing clamps and fasteners

Width mm	
150	LFBC/0150HDG/60R300
300	LFBC/0300HDG/60R300
450	LFBC/0450HDG/60R300
600	LFBC/0600HDG/60R300
750	LFBC/0750HDG/60R300
900	LFBC/0900HDG/60R300



45° flat bend covers (made to order)

Standard radius 300mm = R300, other radii R450, R600, R750 and R900 (made to order).
 Finish: hot dip galvanised = HDG, substitute SS within part number for stainless steel grade 1.4404 (316L)
 Standard closed covers = C, ventilated cover = CV
 Includes fixing clamps and fasteners

Width mm	
150	LFBC/0150HDG/45R300
300	LFBC/0300HDG/45R300
450	LFBC/0450HDG/45R300
600	LFBC/0600HDG/45R300
750	LFBC/0750HDG/45R300
900	LFBC/0900HDG/45R300



30° flat bend covers (made to order)

Standard radius 300mm = R300, other radii R450, R600, R750 and R900 (made to order).
 Finish: hot dip galvanised = HDG, substitute SS within part number for stainless steel grade 1.4404 (316L)
 Standard closed covers = C, ventilated cover = CV
 Includes fixing clamps and fasteners

Width mm	
150	LFBC/0150HDG/30R300
300	LFBC/0300HDG/30R300
450	LFBC/0450HDG/30R300
600	LFBC/0600HDG/30R300
750	LFBC/0750HDG/30R300
900	LFBC/0900HDG/30R300



Equal tee covers (made to order)

Standard radius 300mm = R300, other radii R450, R600, R750 and R900 (made to order).
 Finish: hot dip galvanised = HDG, substitute SS within part number for stainless steel grade 1.4404 (316L)
 Standard closed covers = C, ventilated cover = CV
 Includes fixing clamps and fasteners

Width mm	
150	LETC/0150HDGR300
300	LETC/0300HDGR300
450	LETC/0450HDGR300
600	LETC/0600HDGR300
750	LETC/0750HDGR300
900	LETC/0900HDGR300

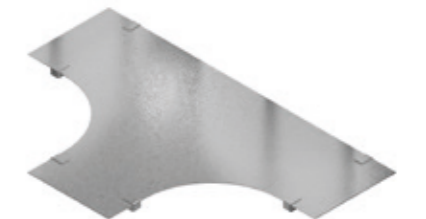

Unequal tee covers (made to order)

Standard radius 300mm = R300, other radii R450, R600, R750 and R900.
 Finish: hot dip galvanised = HDG, substitute SS within part number for stainless steel grade 1.4404 (316L)
 Standard closed covers = C, ventilated cover = CV
 Includes fixing clamps and fasteners
 How to generate the part number – LUTC (cover type)/W1/W2 (finish) (radius)
 Example – LUTC/0300/0150HDGR300
 Table below shows a complete list of W1 and W2 combinations.

W1	W2
150	300, 450, 600, 750, 900
300	150, 450, 600, 750, 900
450	150, 300, 600, 750, 900
600	150, 300, 450, 750, 900
750	150, 300, 450, 600, 900
900	150, 300, 450, 600, 750



Crossover covers (made to order)

Standard radius 300mm = R300, other radii R450, R600, R750 and R900 (made to order).
 Finish: hot dip galvanised = HDG, substitute SS within part number for stainless steel grade 1.4404 (316L)
 Standard closed covers = C, ventilated cover = CV
 Includes fixing clamps and fasteners

Width mm	
150	LCOC/0150HDGR300
300	LCOC/0300HDGR300
450	LCOC/0450HDGR300
600	LCOC/0600HDGR300
750	LCOC/0750HDGR300
900	LCOC/0900HDGR300

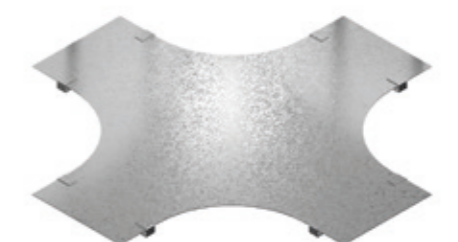

Straight reducer covers (made to order)

Finish: hot dip galvanised = HDG, substitute SS within part number for stainless steel grade 1.4404 (316L)
Standard closed covers = C, ventilated cover = CV
Includes fixing clamps and fasteners

Width mm		
W1	W2	
300	150	LSRC/0300/0150HDG
450	150	LSRC/0450/0150HDG
600	150	LSRC/0600/0150HDG
750	150	LSRC/0750/0150HDG
900	150	LSRC/0900/0150HDG
450	300	LSRC/0450/0300HDG
600	300	LSRC/0600/0300HDG
750	300	LSRC/0750/0300HDG
900	300	LSRC/0900/0300HDG
600	450	LSRC/0600/0450HDG
750	450	LSRC/0750/0450HDG
900	450	LSRC/0900/0450HDG
750	600	LSRC/0750/0600HDG
900	600	LSRC/0900/0600HDG
900	750	LSRC/0900/0750HDG

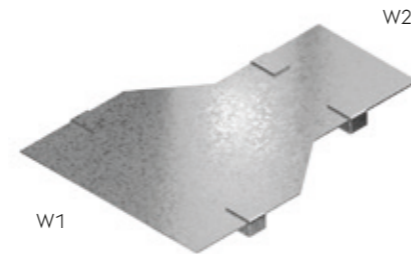
**Right hand reducer covers (made to order)**

Finish: hot dip galvanised = HDG, substitute SS within part number for stainless steel grade 1.4404 (316L)
Standard closed covers = C, ventilated cover = CV
Includes fixing clamps and fasteners

Width mm		
W1	W2	
300	150	LRRC/0300/0150HDG
450	150	LRRC/0450/0150HDG
600	150	LRRC/0600/0150HDG
750	150	LRRC/0750/0150HDG
900	150	LRRC/0900/0150HDG
450	300	LRRC/0450/0300HDG
600	300	LRRC/0600/0300HDG
750	300	LRRC/0750/0300HDG
900	300	LRRC/0900/0300HDG
600	450	LRRC/0600/0450HDG
750	450	LRRC/0750/0450HDG
900	450	LRRC/0900/0450HDG
750	600	LRRC/0750/0600HDG
900	600	LRRC/0900/0600HDG
900	750	LRRC/0900/0750HDG

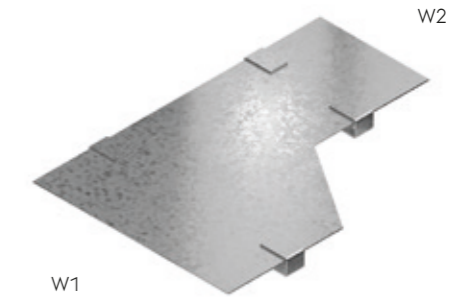
**Left hand reducer covers (made to order)**

Finish: hot dip galvanised = HDG, substitute SS within part number for stainless steel grade 1.4404 (316L)
Standard closed covers = C, ventilated cover = CV
Includes fixing clamps and fasteners

Width mm		
W1	W2	
300	150	LLRC/0300/0150HDG
450	150	LLRC/0450/0150HDG
600	150	LLRC/0600/0150HDG
750	150	LLRC/0750/0150HDG
900	150	LLRC/0900/0150HDG
450	300	LLRC/0450/0300HDG
600	300	LLRC/0600/0300HDG
750	300	LLRC/0750/0300HDG
900	300	LLRC/0900/0300HDG
600	450	LLRC/0600/0450HDG
750	450	LLRC/0750/0450HDG
900	450	LLRC/0900/0450HDG
750	600	LLRC/0750/0600HDG
900	600	LLRC/0900/0600HDG
900	750	LLRC/0900/0750HDG

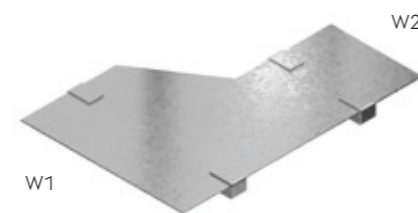
**90° external riser covers (made to order)**

Standard radius 300mm = R300, other radii R450, R600, R750 and R900 (made to order)
Finish: hot dip galvanised = HDG, substitute SS within part number for stainless steel grade 1.4404 (316L)
Standard closed covers = C, ventilated cover = CV
Includes fixing clamps and fasteners

Width mm	Light duty 50mm Deep	Medium duty 100mm Deep	Heavy duty 125mm Deep	Extra heavy duty 150mm Deep
150	LERC050/0150HDG/90R300	LERC100/0150HDG/90R300	LERC125/0150HDG/90R300	LERC150/0150HDG/90R300
300	LERC050/0300HDG/90R300	LERC100/0300HDG/90R300	LERC125/0300HDG/90R300	LERC150/0300HDG/90R300
450	LERC050/0450HDG/90R300	LERC100/0450HDG/90R300	LERC125/0450HDG/90R300	LERC150/0450HDG/90R300
600	N/A	LERC100/0600HDG/90R300	LERC125/0600HDG/90R300	LERC150/0600HDG/90R300
750	N/A	LERC100/0750HDG/90R300	LERC125/0750HDG/90R300	LERC150/0750HDG/90R300
900	N/A	LERC100/0900HDG/90R300	LERC125/0900HDG/90R300	LERC150/0900HDG/90R300

**60° external riser covers (made to order)**

Standard radius 300mm = R300, other radii R450, R600, R750 and R900 (made to order)
Finish: hot dip galvanised = HDG, substitute SS within part number for stainless steel grade 1.4404 (316L)
Standard closed covers = C, ventilated cover = CV
Includes fixing clamps and fasteners

Width mm	Light duty 50mm Deep	Medium duty 100mm Deep	Heavy duty 125mm Deep	Extra heavy duty 150mm Deep
150	LERC050/0150HDG/60R300	LERC100/0150HDG/60R300	LERC125/0150HDG/60R300	LERC150/0150HDG/60R300
300	LERC050/0300HDG/60R300	LERC100/0300HDG/60R300	LERC125/0300HDG/60R300	LERC150/0300HDG/60R300
450	LERC050/0450HDG/60R300	LERC100/0450HDG/60R300	LERC125/0450HDG/60R300	LERC150/0450HDG/60R300
600	N/A	LERC100/0600HDG/60R300	LERC125/0600HDG/60R300	LERC150/0600HDG/60R300
750	N/A	LERC100/0750HDG/60R300	LERC125/0750HDG/60R300	LERC150/0750HDG/60R300
900	N/A	LERC100/0900HDG/60R300	LERC125/0900HDG/60R300	LERC150/0900HDG/60R300

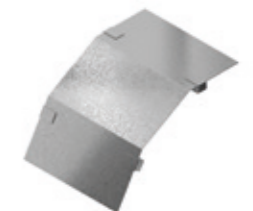

45° external riser covers (made to order)

Standard radius 300mm = R300, other radii R450, R600, R750 and R900 (made to order)

Finish: hot dip galvanised = HDG, substitute SS within part number for stainless steel grade 1.4404 (316L)

Standard closed covers = C, ventilated cover = CV

Includes fixing clamps and fasteners

Width mm	Light duty 50mm Deep	Medium duty 100mm Deep	Heavy duty 125mm Deep	Extra heavy duty 150mm Deep
150	LERC050/0150HDG/45R300	LERC100/0150HDG/45R300	LERC125/0150HDG/45R300	LERC150/0150HDG/45R300
300	LERC050/0300HDG/45R300	LERC100/0300HDG/45R300	LERC125/0300HDG/45R300	LERC150/0300HDG/45R300
450	LERC050/0450HDG/45R300	LERC100/0450HDG/45R300	LERC125/0450HDG/45R300	LERC150/0450HDG/45R300
600	N/A	LERC100/0600HDG/45R300	LERC125/0600HDG/45R300	LERC150/0600HDG/45R300
750	N/A	LERC100/0750HDG/45R300	LERC125/0750HDG/45R300	LERC150/0750HDG/45R300
900	N/A	LERC100/0900HDG/45R300	LERC125/0900HDG/45R300	LERC150/0900HDG/45R300

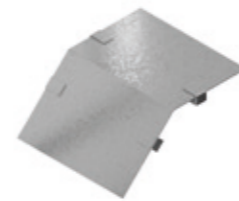
**30° external riser covers (made to order)**

Standard radius 300mm = R300, other radii R450, R600, R750 and R900 (made to order)

Finish: hot dip galvanised = HDG, substitute SS within part number for stainless steel grade 1.4404 (316L)

Standard closed covers = C, ventilated cover = CV

Includes fixing clamps and fasteners

Width mm	Light duty 50mm Deep	Medium duty 100mm Deep	Heavy duty 125mm Deep	Extra heavy duty 150mm Deep
150	LERC050/0150HDG/30R300	LERC100/0150HDG/30R300	LERC125/0150HDG/30R300	LERC150/0150HDG/30R300
300	LERC050/0300HDG/30R300	LERC100/0300HDG/30R300	LERC125/0300HDG/30R300	LERC150/0300HDG/30R300
450	LERC050/0450HDG/30R300	LERC100/0450HDG/30R300	LERC125/0450HDG/30R300	LERC150/0450HDG/30R300
600	N/A	LERC100/0600HDG/30R300	LERC125/0600HDG/30R300	LERC150/0600HDG/30R300
750	N/A	LERC100/0750HDG/30R300	LERC125/0750HDG/30R300	LERC150/0750HDG/30R300
900	N/A	LERC100/0900HDG/30R300	LERC125/0900HDG/30R300	LERC150/0900HDG/30R300

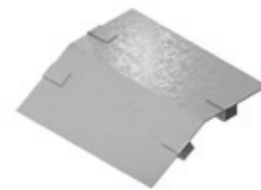
**90° internal riser covers (made to order)**

Standard radius 300mm = R300, other radii R450, R600, R750 and R900 (made to order)

Finish: hot dip galvanised = HDG, substitute SS within part number for stainless steel grade 1.4404 (316L)

Standard closed covers = C, ventilated cover = CV

Includes fixing clamps and fasteners

Width mm	
150	LIRC/0150HDG/90R300
300	LIRC/0300HDG/90R300
450	LIRC/0450HDG/90R300
600	LIRC/0600HDG/90R300
750	LIRC/0750HDG/90R300
900	LIRC/0900HDG/90R300

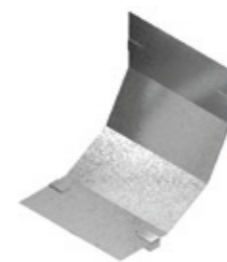
**60° internal riser covers (made to order)**

Standard radius 300mm = R300, other radii R450, R600, R750 and R900 (made to order)

Finish: hot dip galvanised = HDG, substitute SS within part number for stainless steel grade 1.4404 (316L)

Standard closed covers = C, ventilated cover = CV

Includes fixing clamps and fasteners

Width mm	
150	LIRC/0150HDG/60R300
300	LIRC/0300HDG/60R300
450	LIRC/0450HDG/60R300
600	LIRC/0600HDG/60R300
750	LIRC/0750HDG/60R300
900	LIRC/0900HDG/60R300

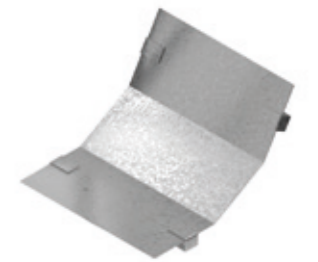
**45° internal riser covers (made to order)**

Standard radius 300mm = R300, other radii R450, R600, R750 and R900 (made to order)

Finish: hot dip galvanised = HDG, substitute SS within part number for stainless steel grade 1.4404 (316L)

Standard closed covers = C, ventilated cover = CV

Includes fixing clamps and fasteners

Width mm	
150	LIRC/0150HDG/45R300
300	LIRC/0300HDG/45R300
450	LIRC/0450HDG/45R300
600	LIRC/0600HDG/45R300
750	LIRC/0750HDG/45R300
900	LIRC/0900HDG/45R300

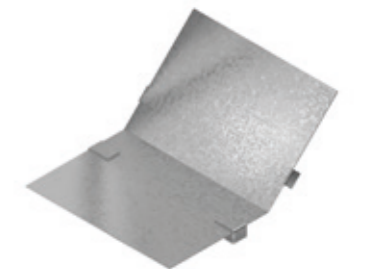
**30° internal riser covers (made to order)**

Standard radius 300mm = R300, other radii R450, R600, R750 and R900 (made to order)

Finish: hot dip galvanised = HDG, substitute SS within part number for stainless steel grade 1.4404 (316L)

Standard closed covers = C, ventilated cover = CV

Includes fixing clamps and fasteners

Width mm	
150	LIRC/0150HDG/30R300
300	LIRC/0300HDG/30R300
450	LIRC/0450HDG/30R300
600	LIRC/0600HDG/30R300
750	LIRC/0750HDG/30R300
900	LIRC/0900HDG/30R300

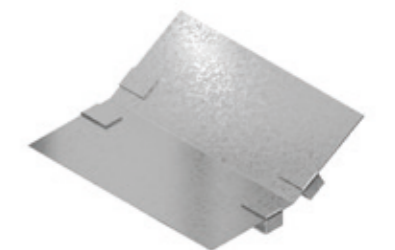

Accessories

Splice plates

Finish: hot dip galvanised as standard. For stainless steel grade 1.4404 (316L) add SS e.g. L/SSP100SSPR

Ladder depth mm	Sold in pairs (includes 16 nuts, bolts and washers)
50	L/SSP50PR
100	L/SSP100PR
125	L/SSP125PR
150	L/SSP150PR



Vertical splice plates

Finish: hot dip galvanised as standard. For stainless steel grade 1.4404 (316L) add SS e.g. L/VSP100SSPR

Ladder depth mm	Sold in pairs (includes 16 nuts, bolts and washers)
50	L/VSP50PR
100	L/VSP100PR
125	L/VSP125PR
150	L/VSP150PR

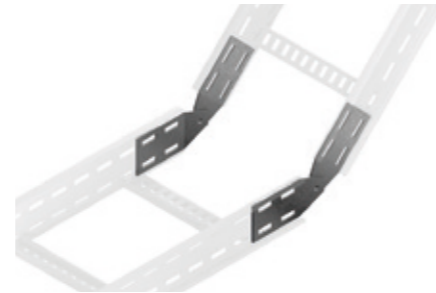

Horizontal splice plates

Finish: hot dip galvanised as standard. For stainless steel grade 1.4404 (316L) add SS e.g. L/HSP100SSPR

Ladder depth mm	Sold in pairs (includes 16 nuts, bolts and washers)
50	L/HSP50PR
100	L/HSP100PR
125	L/HSP125PR
150	L/HSP150PR

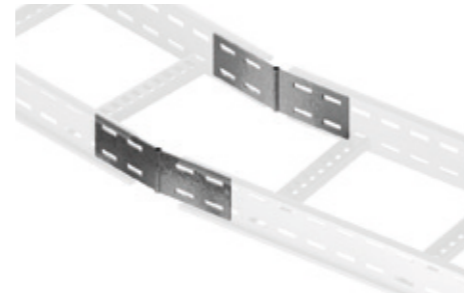

Hold down bracket

Finish: hot dip galvanised as standard. For stainless steel grade 1.4404 (316L) add SS e.g. L/HDB100SS

Ladder depth mm	Sold as single item (fasteners excluded)
50	L/HDB50
100	L/HDB100
125	L/HDB125
150	L/HDB150

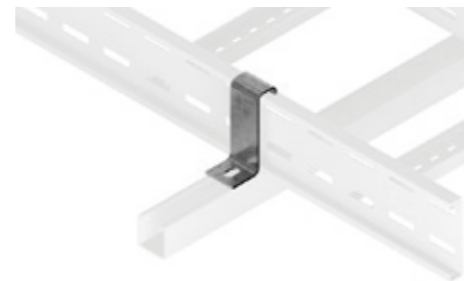

Suspension clip

Finish: hot dip galvanised as standard. For stainless steel grade 1.4404 (316L) add SS e.g. L/SC100SS
Slot diameter is 12mm x 20mm.

Ladder depth mm	Sold as single item (fasteners excluded)
50	L/SC50
100	L/SC100
125	L/SC125
150	L/SC150



Hold down clip

Finish: hot dip galvanised as standard. For stainless steel grade 1.4404 (316L) add SS e.g. L/HDC/ASS

Sold as single item (fasteners excluded)

L/HDC/A

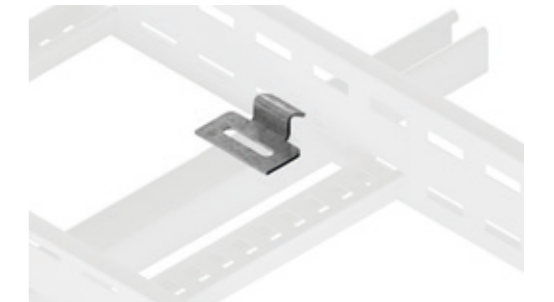

Bolted hold down clip

Finish: hot dip galvanised as standard. For stainless steel grade 1.4404 (316L) add SS e.g. L/HDC/BSS

Sold as single item (fasteners excluded)

L/HDC/B



Side rail clamp

Finish: hot dip galvanised as standard. For stainless steel grade 1.4404 (316L) add SS e.g. L/SRC/SS

Sold as single item (fasteners excluded)

L/SRC



Bendable splice plates

Finish: hot dip galvanised as standard. For stainless steel grade 1.4404 (316L) add SS e.g. L/BSP100/SSPR

Ladder depth mm	Sold in pairs (includes 16 nuts, bolts and washers)
50	L/BSP050PR
100	L/BSP100PR
125	L/BSP125PR
150	L/BSP150PR

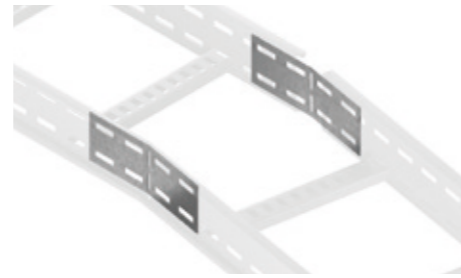
**End connectors**

Finish: hot dip galvanised as standard. For stainless steel grade 1.4404 (316L) add SS e.g. L/ECO100SSPR

Ladder depth mm	Sold in pairs (fasteners excluded)
50	L/ECO50PR
100	L/ECO100PR
125	L/ECO125PR
150	L/ECO150PR

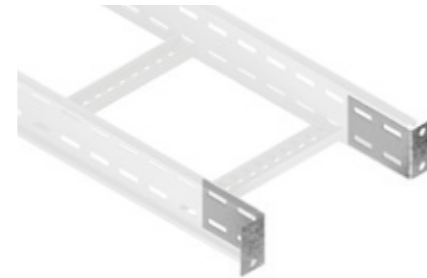
**Stop ends**

Finish: hot dip galvanised as standard. For stainless steel grade 1.4404 (316L) add SS e.g. L/SE100/0300SS.
Sold as single item (fasteners excluded)

Width mm	Light duty 50mm Deep	Medium duty 100mm Deep	Heavy duty 125mm Deep	Extra heavy duty 150mm Deep
150	L/SE050/0150	L/SE100/0150	L/SE125/0150	L/SE150/0150
300	L/SE050/0300	L/SE100/0300	L/SE125/0300	L/SE150/0300
450	L/SE050/0450	L/SE100/0450	L/SE125/0450	L/SE150/0450
600	N/A	L/SE100/0600	L/SE125/0600	L/SE150/0600
750	N/A	L/SE100/0750	L/SE125/0750	L/SE150/0750
900	N/A	L/SE100/0900	L/SE125/0900	L/SE150/0900

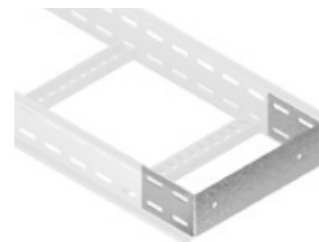
**Drop out plates**

Finish: hot dip galvanised as standard. For stainless steel grade 1.4404 (316L) add SS e.g. L/DOP150SS

Ladder depth mm	Sold as single item (fasteners excluded)
150	L/DOP150
300	L/DOP300
450	L/DOP450
600	L/DOP600
750	L/DOP750
900	L/DOP900

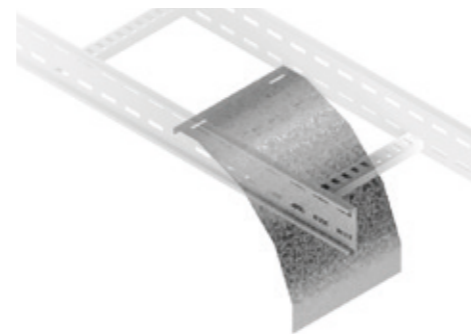
**Drop out brackets**

Finish: hot dip galvanised as standard. For stainless steel grade 1.4404 (316L) add SS e.g. L/RTR100SSPR

Ladder depth mm	Sold in pairs (fasteners excluded)
50	N/A
100	L/RTR100PR
125	L/RTR125PR
150	L/RTR150PR

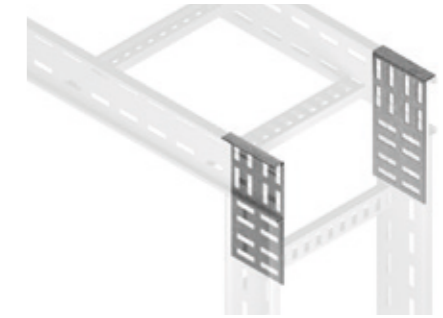
**Wall brackets**

Finish: hot dip galvanised as standard. For stainless steel grade 1.4404 (316L) add SS e.g. L/WSB100SSPR

Ladder depth mm	Sold in pairs (fasteners excluded)
50	L/WSB050PR
100	L/WSB100PR
125	L/WSB125PR
150	L/WSB150PR

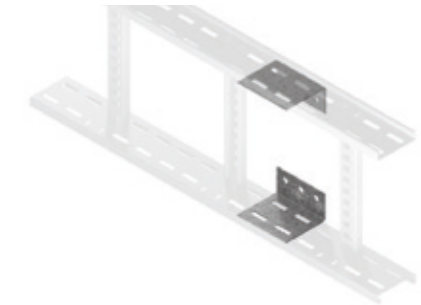
**Straight divider – 3m long**

Finish: hot dip galvanised as standard. For stainless steel grade 1.4404 (316L) add SS e.g. LSD100/3SS

Ladder depth mm	Sold as single item (fasteners excluded)
50	LSD050/3
100	LSD100/3
125	LSD125/3
150	LSD150/3

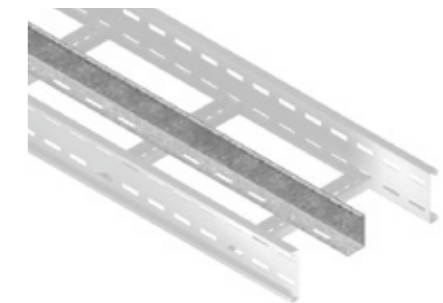
**Bendable divider – 1m long**

Finish: hot dip galvanised as standard. For stainless steel grade 1.4404 (316L) add SS e.g. LBD100SS

Ladder depth mm	Sold as single item (fasteners excluded)
50	LBD050
100	LBD100
125	LBD125
150	LBD150

**Earth straps**

Finish: copper braid Electro Tinned – 16mm²
Hole diameter is 12mm.

250mm long (fasteners excluded)

L/ES250



CABLE LADDER SYSTEMS

Pre-Galvanised Cable Ladder Systems

Metsec pre-galvanised ladders are made using a non-destructive jointing method called clinching. This enables a strong and robust product to be created without damage to the corrosion resistant coating, to ensure the optimum level of protection is maintained. A full range of accessories are available as well as splice plates which come complete with M10 cup square bolts, shake proof washers and nuts.

When installing metsec cable ladders, care should be taken to ensure the support is within 600mm of a joint. Accessories (e.g. bends, tees, crossovers etc.) should have adequate support. Additional support will be required for larger components.

Technical construction details

Whilst rungs are alternately reversed as standard, other rung orientations can be produced to order. Additionally alternative widths are also available to meet the requirements of the European markets.

Straight ladder

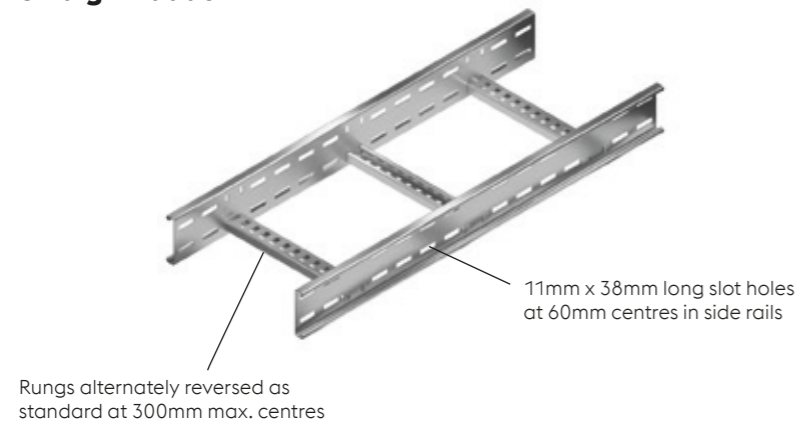

Rung types

50, 100, 125 and 150mm deep ladder ranges
rung type: 41mm x 21mm channel

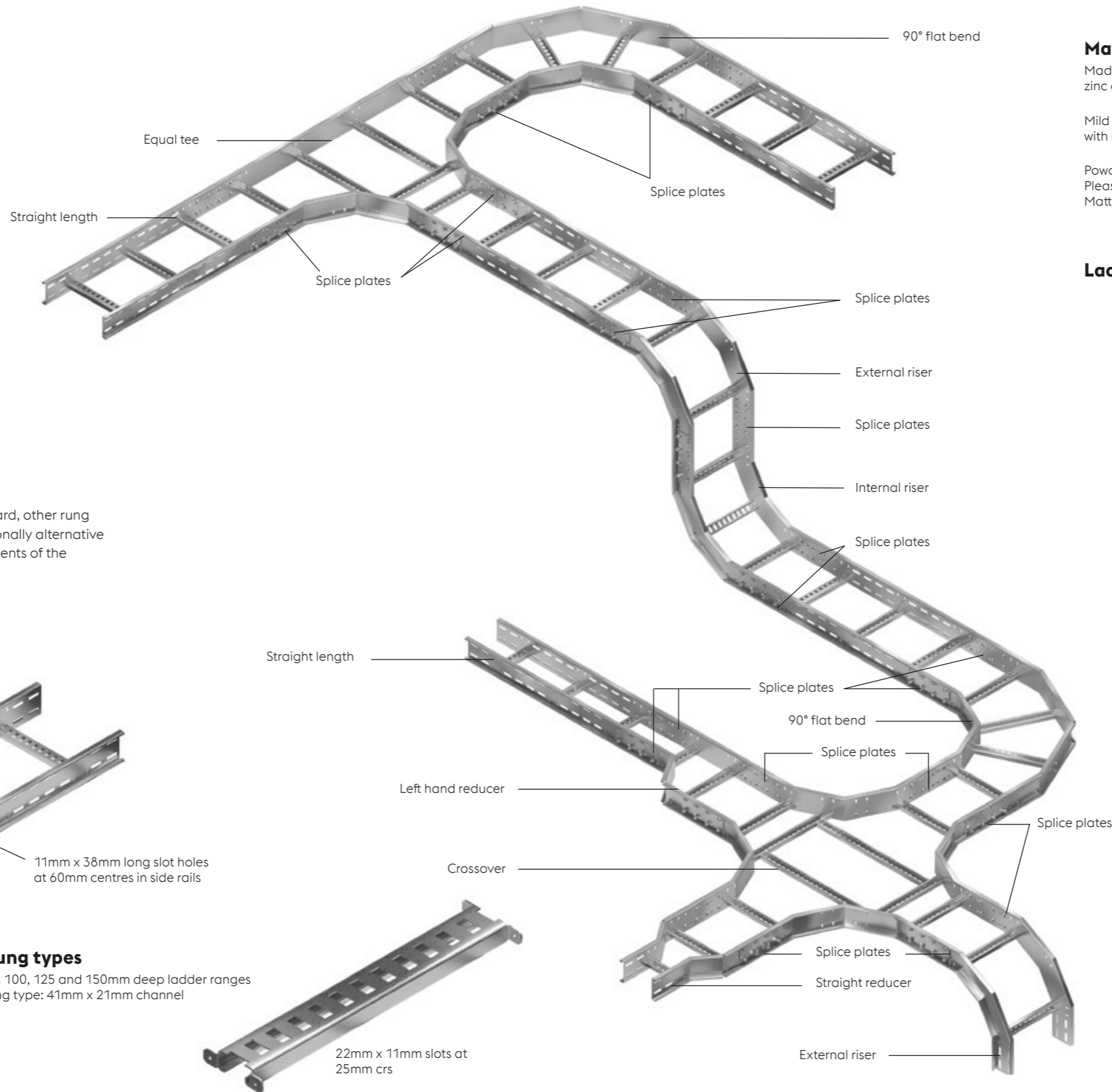
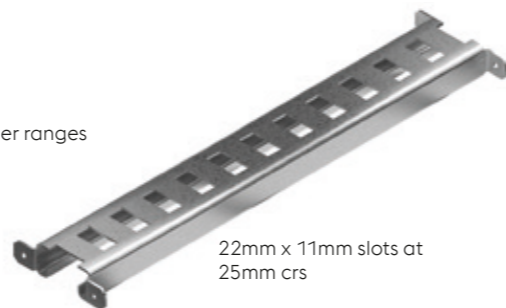

Materials and finishes

Made from pre-galvanised steel grade S280 with a 275g/m² zinc coating.

Mild steel Pre-galvanised: manufactured from steel complying with BS EN 10346.

Powder coating is available as an additional surface finish. Please provide the required RAL or BS colour and the level of Matt/Semi or Gloss when ordering.

Ladder profiles

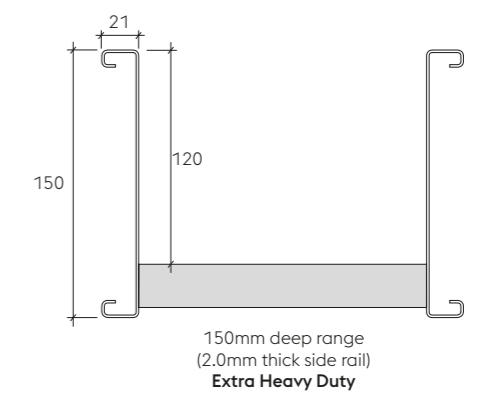
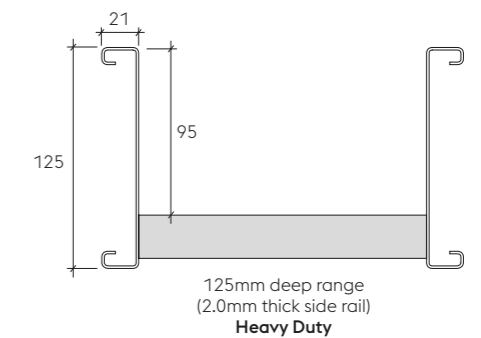
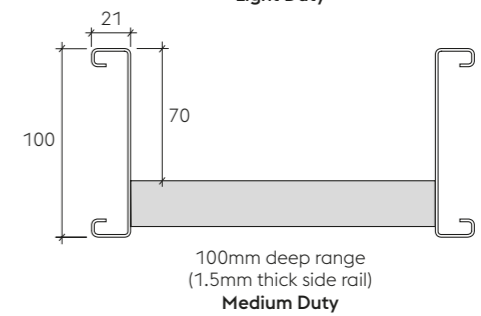
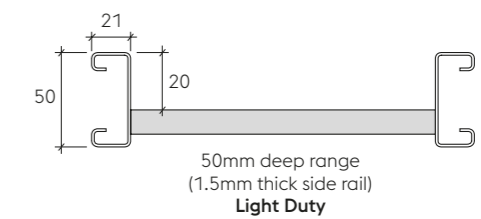

The Metsec Pre-Galvanised Ladder has been specially designed to provide a high quality, Cable Management solution across a wide range of market sectors.



Features

- » Metsec's team of specialist engineers manufacture flat bends, tees and crossovers, risers, reducers and covers, all designed to fit into a complete ladder system with a range of accessories for ease of installation
- » For projects requiring long, straight runs of cable ladder, lengths of up to 6m can be manufactured to order
- » Aesthetically superior to traditional hot dipped finish
- » Splice plates are supplied complete with M10 cup square bolts, shake proof washers, and nuts with a high tolerance fit for optimum structural performance.

Key Benefits

- » Proven to meet recognised industry standards through rigorous BSI Kitemark™ testing, demonstrating safety, reliability and quality
- » Conforms to BS EN 61537 for Cable Management, cable tray systems and cable ladder systems
- » Assembled using a non-destructive process, eliminating any risk of damage to the galvanised coating
- » Offers equivalent loading performance of our welded ladder system.



Industry Sectors

The Pre-Galvanised ladder is suitable for many industries: Commercial, Education, Health, Retail, Telecoms and Tunnels.

Load Table

Our load table is provided to enable easy comparison and cost optimisation. This data assumes an even distribution across the width of the ladder in a horizontal plane and that the load is similar across two or more continuous spans. For non-uniform loads, or spans/loadings outside the scope of the tables, please contact Metsec for advice.

Example

Load required = 100kg per linear metre options available

1. 50mm deep ladder will span up to a maximum of 2.438m with a deflection of 11.6mm
2. 100mm deep ladder will span up to a maximum of 4.021m with a deflection of 15.8mm
3. 125mm deep ladder will span up to a maximum of 5.414m with a deflection of 23.0mm
4. 150mm deep ladder will span up to a maximum of 5.827m with a deflection of 19.4mm

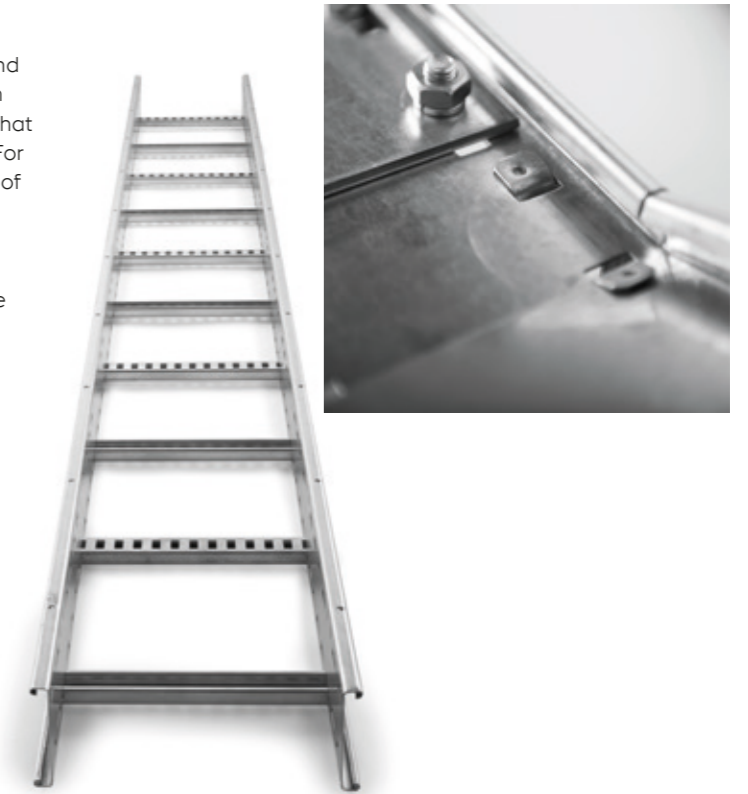

Load W kg/m	Type											
	50mm Deep			100mm Deep			125mm Deep			150mm Deep		
	s	d	dp	s	d	dp	s	d	dp	s	d	dp
25	3.931	19.7	19.7	6.000	19.6	30.0	6.000	8.7	30.0	6.000	5.4	30.0
50	3.120	15.6	15.6	5.487	27.4	27.4	6.000	17.3	30.0	6.000	10.9	30.0
75	2.725	13.6	13.6	4.643	21.1	23.2	6.000	26.0	30.0	6.000	16.3	30.0
100	2.438	11.6	12.2	4.021	15.8	20.1	5.414	23.0	27.1	5.827	19.4	29.1
125	2.181	9.3	10.9	3.512	11.5	17.6	4.843	18.4	24.2	5.212	15.5	26.1
150	1.991	7.8	10.0	3.132	8.7	15.7	4.421	15.3	22.1	4.685	12.2	23.4
175	1.843	6.6	9.2	2.839	6.9	14.2	4.048	12.5	20.2	4.259	9.7	21.3
200	1.724	5.8	8.6	2.604	5.6	13.0	3.728	10.3	18.6	3.918	7.9	19.6
225	1.625	5.2	8.1	2.411	4.6	12.1	3.464	8.7	17.3	3.636	6.6	18.2
250	1.542	4.7	7.7	2.248	3.9	11.2	3.242	7.4	16.2	3.398	5.6	17.0
275	1.470	4.2	7.4	2.109	3.3	10.5	3.051	6.4	15.3	3.195	4.8	16.0
300	1.405	3.8	7.0	1.988	2.8	9.9	2.885	5.6	14.4	3.018	4.2	15.1

's'- maximum spacing of supports in metres

'dp'- allowable deflection (span/200) in mm

'd'- maximum deflection in end span in mm

'w'- safe working load in kg per linear metre

STANDARDS

Metsec cable ladder systems generally conform to BS EN 61537 Cable Management – cable tray systems and cable ladder systems

Information relating to compliance is detailed/highlighted within the following sections of the standard:

6 Classification

6.1	According to material	6.4	According to electrical conductivity
6.1.1	Metsec cable ladder systems are metallic system components	6.4.1	Metsec cable ladder systems are electrically conductive system components
6.2	According to resistance to flame propagation	6.5	According to resistance against corrosion
6.2.2	Metsec cable ladder systems are non-flame propagating system components	6.5.2	Metsec cable ladder systems are made of steel with metallic finishes or stainless steel
6.3	According to electrical continuity characteristics		(Resistance to corrosion is classified according to Table 1. and follow the relevant specification in Table 8, with compliance according to Table 7.)
6.3.2	Metsec cable ladder systems have electrical continuity characteristics		

Table 1 – Classification for resistance against corrosion

Class	Reference – material and finish
0 (a)	None
1	Electroplated to a minimum thickness of 5 µm
2	Electroplated to a minimum thickness of 12 µm
3	Pre-galvanised to grade 275 to BS EN 10346
4	Pre-galvanised to grade 350 to EN 10346
5	Post-galvanised to a zinc mean coating thickness (minimum) of 45 µm according to BS EN ISO 1461 for zinc thickness only
6	Post-galvanised to a zinc mean coating thickness (minimum) of 55 µm according to ISO 1461 for zinc thickness only
7	Post-galvanised to a zinc mean coating thickness (minimum) of 70 µm according to ISO 1461 for zinc thickness only
8	Post-galvanised to a zinc mean coating thickness (minimum) of 85 µm according to ISO 1461 for zinc thickness only
9A	Stainless steel manufactured to ASTM: A 240/A 240M – 95a designation S30400 or EN 10088 grade 1 – 4301 without a post treatment (b)
9B	Stainless steel manufactured to ASTM: A 240/A 240M – 95a designation S31603 or EN 10088 grade 1 – 4404 without a post treatment (b)
9C	Stainless steel manufactured to ASTM: A 240/A 240M – 95a designation S30400 or EN 10088 grade 1 – 4301 with a post treatment (b)
9D	Stainless steel manufactured to ASTM: A 240/A 240M – 95a designation S31603 or EN 10088 grade 1 – 4404 with a post treatment (b)
(a)	For materials which have no declared corrosion resistance classification
(b)	The post-treatment process is used to improve the protection against crevice crack corrosion and the contamination by other steels

Table 7 – System component compliance and classification for resistance against corrosion

System component Material and finishes	Classification according to	Compliance	Subclause for compliance check
Non-metallic	6.5.1	Declaration	14.2.1
Reference – zinc coating as in Table 1.	6.5.2 Table 1 classes 1 to 8	Declaration or measurement	14.2.2
Non-referenced zinc coating	6.5.2 Table 1 classes 1 to 8	By neutral salt spray test NSS	14.2.3
Reference – stainless steel as in Table 1.	6.5.2 Table 1 Class 9A to 9D	Declaration	14.2.2
Non-referenced stainless steel	Not classified	Declaration	None
Other metallic coatings	6.5.2 Table 1 Column 1 classes 1 to 8	By neutral salt spray test NSS	14.2.3
Aluminium alloys or other metals	6.5.3 Under consideration	Under consideration	14.2.4
Organic coatings	6.5.4 Under consideration	Under consideration	14.2.5

Table 8 – Zinc coating thickness of reference materials

Class	Minimum thickness	Minimum coating thickness as given in BS EN 10346	Mean coating thickness (minimum) to ISO 1461
	µm	µm	µm
0 (a)	-	-	-
1	5	-	-
2	12	-	-
3	-	13	-
4	-	17	-
5	-	-	45
6	-	-	55
7	-	-	70
8	-	-	85

a) As declared by the manufacturer or responsible vendor

6.6 According to temperature
6.6.1 Minimum temperature for the system components is given in Table 2.

6.6.2 Maximum temperature for the system components is given in Table 3.

6.8 According to the free base area of the cable ladder length as given in Table 5.

6.9 According to impact resistance

6.9.5 System component offering impact resistance up to 50 J (as verified by testing in accordance with 10.9 Test for impact resistance.)

7 Marking and Documentation

7.1 Each system component is marked by a label. Labels used fully comply with the rubbing test. Boxed items are labelled on the packaging.

8 Dimensions

Key cross sectional dimensions for straight cable ladders

Part No	External depth mm	Internal depth mm	External width mm	Internal width mm	X-sectional area mm ²
LSL050/0150#	50	20	192	150	3000
LSL050/0300#	50	20	342	300	6000
LSL050/0450#	50	20	492	450	9000
LSL100/0150#	100	70	192	150	10500
LSL100/0300#	100	70	342	300	21000
LSL100/0450#	100	70	492	450	31500
LSL100/0600#	100	70	642	600	42000
LSL100/0750#	100	70	792	750	52500
LSL100/0900#	100	70	942	900	63000
LSL125/0150#	125	95	192	150	14250
LSL125/0300#	125	95	342	300	28500
LSL125/0450#	125	95	492	450	42750
LSL125/0600#	125	95	642	600	57000
LSL125/0750#	125	95	792	750	71250
LSL125/0900#	125	95	942	900	85500
LSL150/0150#	150	120	192	150	18000
LSL150/0300#	150	120	342	300	36000
LSL150/0450#	150	120	492	450	54000
LSL150/0600#	150	120	642	600	72000
LSL150/0750#	150	120	792	750	90000
LSL150/0900#	150	120	942	900	108000

Table 2 – Minimum temperature classification

Minimum transport, storage installation and application temperature °C
+5
-5
-15
-20
-40
-50

Table 3 – Maximum temperature classification

Maximum transport, storage installation and application temperature °C
+40
+60
+90
+105
+120
+150

Table 5 – Free base area classification

Classification	Perforation in the free base area
X	Up to 80 %
Y	Over 80 % and up to 90 %
Z	More than 90 %

NB: Classification Z relates to IEC 60364-5-52 Subclause A.52.6.2 third paragraph

Minimum internal radius of fittings

Minimal internal radius of fittings available for the accommodation of cables is 300 mm.

9 Construction

- 9.1 Surfaces of system components which are likely to come into contact with cables during installation are inspected to ensure they shall not cause damage to the cables when installed correctly.
- 9.2 As with all metallic system components, care should be exercised that handling is in accordance with the relative COSHH regulations and gloves should be worn.
- 9.3 Screwed connections have been designed to withstand the mechanical stresses occurring during installations and normal use and will not cause damage to cables when correctly inserted. Screwed connections are in general ISO metric threads fully compliant to tests in accordance with 9.3.1 and 9.3.2 of the standard. Metsec cable ladder systems are usually assembled using M10 cup square bolts and hex nuts with lock washers for couplers etc tightened to a torque of 45N/m. Other connections require M10 hex bolts for clamps etc tightened to a torque of 25N/m.

10 Mechanical Properties

Cable ladder lengths have been tested generally in accordance with the standard under 10.2 and 10.3 for verification of the loading graphs. It should be noted that independent testing has been carried out to verify the structural performance of the cable ladders at the minimum and maximum temperature classifications for test conditions under 10.2.2.

All accessories e.g. bends, tees etc should be directly supported by a suitable support device or devices at appropriate positions.

PRE-GALVANISED LADDER SYSTEMS

Accessory Footprint

Pre-Galvanised ladder – accessory foot print standard radius is 300mm

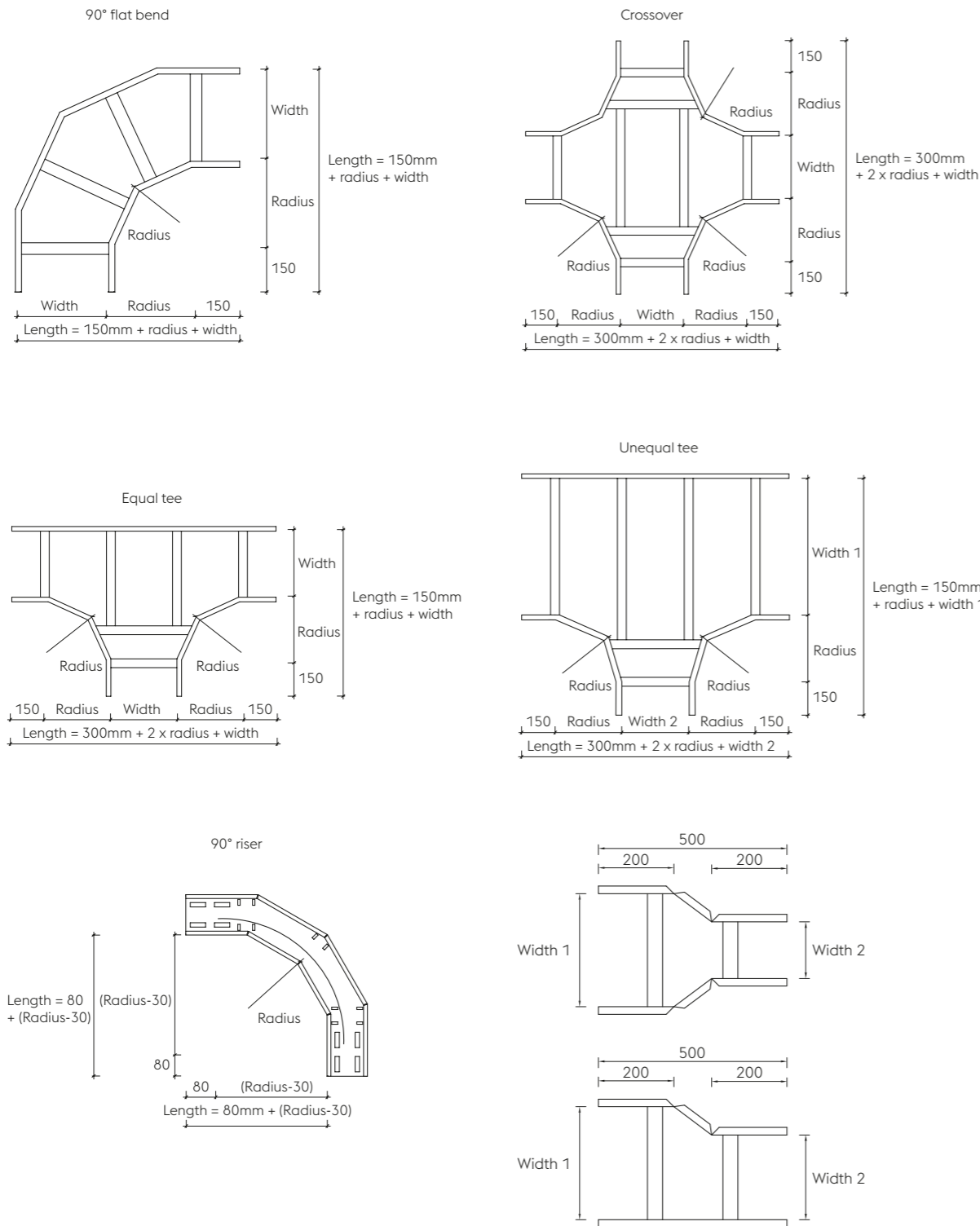

Footprints are identical for all ranges

Straight Lengths

Light duty – 50mm deep

Finish: pre-galvanised = PG

Width mm	50mm Deep – 3M long	50mm Deep – 6M long
150	LSL050/0150PG/3	N/A
300	LSL050/0300PG/3	N/A
450	LSL050/0450PG/3	N/A

Medium duty – 100mm deep

Finish: pre-galvanised = PG

Width mm	100mm Deep – 3M long	100mm Deep – 6M long
150	LSL100/0150PG/3	LSL100/0150PG/6
300	LSL100/0300PG/3	LSL100/0300PG/6
450	LSL100/0450PG/3	LSL100/0450PG/6
600	LSL100/0600PG/3	LSL100/0600PG/6
750	LSL100/0750PG/3	LSL100/0750PG/6
900	LSL100/0900PG/3	LSL100/0900PG/6

Heavy duty 125mm deep

Finish: pre-galvanised = PG

Width mm	125mm Deep – 3M Long	125mm Deep – 6M long
150	LSL125/0150PG/3	LSL125/0150PG/6
300	LSL125/0300PG/3	LSL125/0300PG/6
450	LSL125/0450PG/3	LSL125/0450PG/6
600	LSL125/0600PG/3	LSL125/0600PG/6
750	LSL125/0750PG/3	LSL125/0750PG/6
900	LSL125/0900PG/3	LSL125/0900PG/6

Extra heavy duty – 150mm deep

Finish: pre-galvanised = PG

Width mm	150mm Deep – 3M Long	150mm Deep – 6M Long
150	LSL150/0150PG/3	LSL150/0150PG/6
300	LSL150/0300PG/3	LSL150/0300PG/6
450	LSL150/0450PG/3	LSL150/0450PG/6
600	LSL150/0600PG/3	LSL150/0600PG/6
750	LSL150/0750PG/3	LSL150/0750PG/6
900	LSL150/0900PG/3	LSL150/0900PG/6

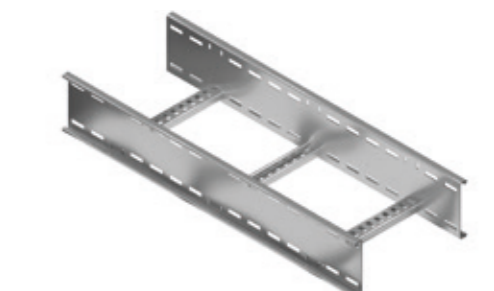
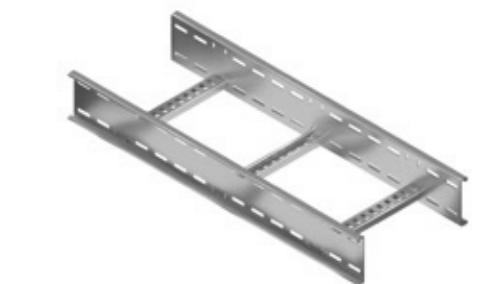
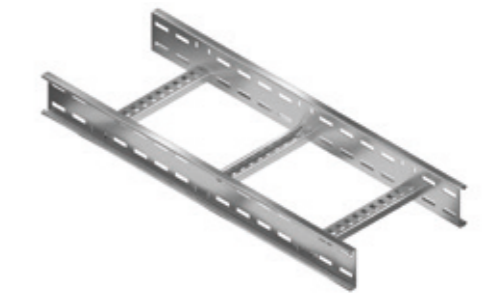

Flat Bends

90° flat bend

Standard radius 300mm = R300, other radii R450, R600, R750 and R900 (made to order).
Finish: pre-galvanised = PG

Width mm	Light duty 50mm Deep	Medium duty 100mm Deep	Heavy duty 125mm Deep	Extra heavy duty 150mm Deep
150	LFB050/0150PG/90R300	LFB100/0150PG/90R300	LFB125/0150PG/90R300	LFB150/0150PG/90R300
300	LFB050/0300PG/90R300	LFB100/0300PG/90R300	LFB125/0300PG/90R300	LFB150/0300PG/90R300
450	LFB050/0450PG/90R300	LFB100/0450PG/90R300	LFB125/0450PG/90R300	LFB150/0450PG/90R300
600	N/A	LFB100/0600PG/90R300	LFB125/0600PG/90R300	LFB150/0600PG/90R300
750	N/A	LFB100/0750PG/90R300	LFB125/0750PG/90R300	LFB150/0750PG/90R300
900	N/A	LFB100/0900PG/90R300	LFB125/0900PG/90R300	LFB150/0900PG/90R300



60° flat bend (made to order)

Standard radius 300mm = R300, other radii R450, R600, R750 and R900 (made to order).
Finish: pre-galvanised = PG

Width mm	Light duty 50mm Deep	Medium duty 100mm Deep	Heavy duty 125mm Deep	Extra heavy duty 150mm Deep
150	LFB050/0150PG/60R300	LFB100/0150PG/60R300	LFB125/0150PG/60R300	LFB150/0150PG/60R300
300	LFB050/0300PG/60R300	LFB100/0300PG/60R300	LFB125/0300PG/60R300	LFB150/0300PG/60R300
450	LFB050/0450PG/60R300	LFB100/0450PG/60R300	LFB125/0450PG/60R300	LFB150/0450PG/60R300
600	N/A	LFB100/0600PG/60R300	LFB125/0600PG/60R300	LFB150/0600PG/60R300
750	N/A	LFB100/0750PG/60R300	LFB125/0750PG/60R300	LFB150/0750PG/60R300
900	N/A	LFB100/0900PG/60R300	LFB125/0900PG/60R300	LFB150/0900PG/60R300



45° flat bend (made to order)

Standard radius 300mm = R300, other radii R450, R600, R750 and R900 (made to order).
Finish: pre-galvanised = PG

Width mm	Light duty 50mm Deep	Medium duty 100mm Deep	Heavy duty 125mm Deep	Extra heavy duty 150mm Deep
150	LFB050/0150PG/45R300	LFB100/0150PG/45R300	LFB125/0150PG/45R300	LFB150/0150PG/45R300
300	LFB050/0300PG/45R300	LFB100/0300PG/45R300	LFB125/0300PG/45R300	LFB150/0300PG/45R300
450	LFB050/0450PG/45R300	LFB100/0450PG/45R300	LFB125/0450PG/45R300	LFB150/0450PG/45R300
600	N/A	LFB100/0600PG/45R300	LFB125/0600PG/45R300	LFB150/0600PG/45R300
750	N/A	LFB100/0750PG/45R300	LFB125/0750PG/45R300	LFB150/0750PG/45R300
900	N/A	LFB100/0900PG/45R300	LFB125/0900PG/45R300	LFB150/0900PG/45R300



30° flat bend (made to order)

Standard radius 300mm = R300, other radii R450, R600, R750 and R900 (made to order).
Finish: pre-galvanised = PG

Width mm	Light duty 50mm Deep	Medium duty 100mm Deep	Heavy duty 125mm Deep	Extra heavy duty 150mm Deep
150	LFB050/0150PG/30R300	LFB100/0150PG/30R300	LFB125/0150PG/30R300	LFB150/0150PG/30R300
300	LFB050/0300PG/30R300	LFB100/0300PG/30R300	LFB125/0300PG/30R300	LFB150/0300PG/30R300
450	LFB050/0450PG/30R300	LFB100/0450PG/30R300	LFB125/0450PG/30R300	LFB150/0450PG/30R300
600	N/A	LFB100/0600PG/30R300	LFB125/0600PG/30R300	LFB150/0600PG/30R300
750	N/A	LFB100/0750PG/30R300	LFB125/0750PG/30R300	LFB150/0750PG/30R300
900	N/A	LFB100/0900PG/30R300	LFB125/0900PG/30R300	LFB150/0900PG/30R300

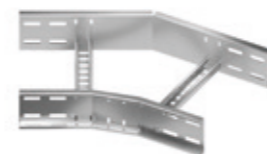

Tees & Crossovers

Equal tee

Standard radius 300mm = R300, other radii R450, R600, R750 and R900 (made to order).
Finish: pre-galvanised = PG

Width mm	Light duty 50mm Deep	Medium duty 100mm Deep	Heavy duty 125mm Deep	Extra heavy duty 150mm Deep
150	LET050/0150PGR300	LET100/0150PGR300	LET125/0150PGR300	LET150/0150PGR300
300	LET050/0300PGR300	LET100/0300PGR300	LET125/0300PGR300	LET150/0300PGR300
450	LET050/0450PGR300	LET100/0450PGR300	LET125/0450PGR300	LET150/0450PGR300
600	N/A	LET100/0600PGR300	LET125/0600PGR300	LET150/0600PGR300
750	N/A	LET100/0750PGR300	LET125/0750PGR300	LET150/0750PGR300
900	N/A	LET100/0900PGR300	LET125/0900PGR300	LET150/0900PGR300



Unequal tee (made to order)

Standard radius 300mm = R300, other radii R450, R600, R750 and R900.
Finish: pre-galvanised = PG

How to generate the part number - LUT(depth)/W1/W2(finish)(radius)
Example - LUT100/0300/0150PGR300

Table below shows a complete list of W1 and W2 combinations.

W1	W2
150	300, 450, 600, 750, 900
300	150, 450, 600, 750, 900
450	150, 300, 600, 750, 900
600	150, 300, 450, 750, 900
750	150, 300, 450, 600, 900
900	150, 300, 450, 600, 750



Crossover

Standard radius 300mm = R300, other radii R450, R600, R750 and R900 (made to order).
Finish: pre-galvanised = PG

Width mm	Light duty 50mm Deep	Medium duty 100mm Deep	Heavy duty 125mm Deep	Extra heavy duty 150mm Deep
150	LCO050/0150PGR300	LCO100/0150PGR300	LCO125/0150PGR300	LCO150/0150PGR300
300	LCO050/0300PGR300	LCO100/0300PGR300	LCO125/0300PGR300	LCO150/0300PGR300
450	LCO050/0450PGR300	LCO100/0450PGR300	LCO125/0450PGR300	LCO150/0450PGR300
600	N/A	LCO100/0600PGR300	LCO125/0600PGR300	LCO150/0600PGR300
750	N/A	LCO100/0750PGR300	LCO125/0750PGR300	LCO150/0750PGR300
900	N/A	LCO100/0900PGR300	LCO125/0900PGR300	LCO150/0900PGR300



Reducers

Straight reducer

Finish: pre-galvanised = PG

Width mm		Light duty 50mm Deep	Medium duty 100mm Deep	Heavy duty 125mm Deep	Extra heavy duty 150mm Deep
W1	W2				
300	150	LSR050/0300/0150PG	LSR100/0300/0150PG	LSR125/0300/0150PG	LSR150/0300/0150PG
450	150	LSR050/0450/0150PG	LSR100/0450/0150PG	LSR125/0450/0150PG	LSR150/0450/0150PG
600	150	N/A	LSR100/0600/0150PG	LSR125/0600/0150PG	LSR150/0600/0150PG
750	150	N/A	LSR100/0750/0150PG	LSR125/0750/0150PG	LSR150/0750/0150PG
900	150	N/A	LSR100/0900/0150PG	LSR125/0900/0150PG	LSR150/0900/0150PG
450	300	LSR050/0450/0300PG	LSR100/0450/0300PG	LSR125/0450/0300PG	LSR150/0450/0300PG
600	300	N/A	LSR100/0600/0300PG	LSR125/0600/0300PG	LSR150/0600/0300PG
750	300	N/A	LSR100/0750/0300PG	LSR125/0750/0300PG	LSR150/0750/0300PG
900	300	N/A	LSR100/0900/0300PG	LSR125/0900/0300PG	LSR150/0900/0300PG
600	450	N/A	LSR100/0600/0450PG	LSR125/0600/0450PG	LSR150/0600/0450PG
750	450	N/A	LSR100/0750/0450PG	LSR125/0750/0450PG	LSR150/0750/0450PG
900	450	N/A	LSR100/0900/0450PG	LSR125/0900/0450PG	LSR150/0900/0450PG
750	600	N/A	LSR100/0750/0600PG	LSR125/0750/0600PG	LSR150/0750/0600PG
900	600	N/A	LSR100/0900/0600PG	LSR125/0900/0600PG	LSR150/0900/0600PG
900	750	N/A	LSR100/0900/0750PG	LSR125/0900/0750PG	LSR150/0900/0750PG



Right hand reducer

Finish: pre-galvanised = PG

Width mm		Light duty 50mm Deep	Medium duty 100mm Deep	Heavy duty 125mm Deep	Extra heavy duty 150mm Deep
W1	W2				
300	150	LRR050/0300/0150PG	LRR100/0300/0150PG	LRR125/0300/0150PG	LRR150/0300/0150PG
450	150	LRR050/0450/0150PG	LRR100/0450/0150PG	LRR125/0450/0150PG	LRR150/0450/0150PG
600	150	N/A	LRR100/0600/0150PG	LRR125/0600/0150PG	LRR150/0600/0150PG
750	150	N/A	LRR100/0750/0150PG	LRR125/0750/0150PG	LRR150/0750/0150PG
900	150	N/A	LRR100/0900/0150PG	LRR125/0900/0150PG	LRR150/0900/0150PG
450	300	LRR050/0450/0300PG	LRR100/0450/0300PG	LRR125/0450/0300PG	LRR150/0450/0300PG
600	300	N/A	LRR100/0600/0300PG	LRR125/0600/0300PG	LRR150/0600/0300PG
750	300	N/A	LRR100/0750/0300PG	LRR125/0750/0300PG	LRR150/0750/0300PG
900	300	N/A	LRR100/0900/0300PG	LRR125/0900/0300PG	LRR150/0900/0300PG
600	450	N/A	LRR100/0600/0450PG	LRR125/0600/0450PG	LRR150/0600/0450PG
750	450	N/A	LRR100/0750/0450PG	LRR125/0750/0450PG	LRR150/0750/0450PG
900	450	N/A	LRR100/0900/0450PG	LRR125/0900/0450PG	LRR150/0900/0450PG
750	600	N/A	LRR100/0750/0600PG	LRR125/0750/0600PG	LRR150/0750/0600PG
900	600	N/A	LRR100/0900/0600PG	LRR125/0900/0600PG	LRR150/0900/0600PG
900	750	N/A	LRR100/0900/0750PG	LRR125/0900/0750PG	LRR150/0900/0750PG

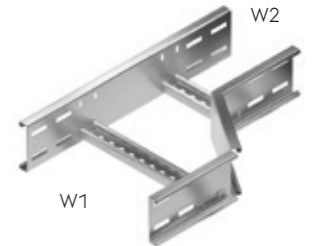

Left hand reducer

Finish: pre-galvanised = PG

Width mm		Light duty 50mm Deep	Medium duty 100mm Deep	Heavy duty 125mm Deep	Extra heavy duty 150mm Deep
W1	W2				
300	150	LLR050/0300/0150PG	LLR100/0300/0150PG	LLR125/0300/0150PG	LLR150/0300/0150PG
450	150	LLR050/0450/0150PG	LLR100/0450/0150PG	LLR125/0450/0150PG	LLR150/0450/0150PG
600	150	N/A	LLR100/0600/0150PG	LLR125/0600/0150PG	LLR150/0600/0150PG
750	150	N/A	LLR100/0750/0150PG	LLR125/0750/0150PG	LLR150/0750/0150PG
900	150	N/A	LLR100/0900/0150PG	LLR125/0900/0150PG	LLR150/0900/0150PG
450	300	LLR050/0450/0300PG	LLR100/0450/0300PG	LLR125/0450/0300PG	LLR150/0450/0300PG
600	300	N/A	LLR100/0600/0300PG	LLR125/0600/0300PG	LLR150/0600/0300PG
750	300	N/A	LLR100/0750/0300PG	LLR125/0750/0300PG	LLR150/0750/0300PG
900	300	N/A	LLR100/0900/0300PG	LLR125/0900/0300PG	LLR150/0900/0300PG
600	450	N/A	LLR100/0600/0450PG	LLR125/0600/0450PG	LLR150/0600/0450PG
750	450	N/A	LLR100/0750/0450PG	LLR125/0750/0450PG	LLR150/0750/0450PG
900	450	N/A	LLR100/0900/0450PG	LLR125/0900/0450PG	LLR150/0900/0450PG
750	600	N/A	LLR100/0750/0600PG	LLR125/0750/0600PG	LLR150/0750/0600PG
900	600	N/A	LLR100/0900/0600PG	LLR125/0900/0600PG	LLR150/0900/0600PG
900	750	N/A	LLR100/0900/0750PG	LLR125/0900/0750PG	LLR150/0900/0750PG



Risers

90° external riser

Standard radius 300mm = R300, other radii R450, R600, R750 and R900 (made to order)

Finish: pre-galvanised = PG

Width mm	Light duty 50mm Deep	Medium duty 100mm Deep	Heavy duty 125mm Deep	Extra heavy duty 150mm Deep
150	LER050/0150PG/90R300	LER100/0150PG/90R300	LER125/0150PG/90R300	LER150/0150PG/90R300
300	LER050/0300PG/90R300	LER100/0300PG/90R300	LER125/0300PG/90R300	LER150/0300PG/90R300
450	LER050/0450PG/90R300	LER100/0450PG/90R300	LER125/0450PG/90R300	LER150/0450PG/90R300
600	N/A	LER100/0600PG/90R300	LER125/0600PG/90R300	LER150/0600PG/90R300
750	N/A	LER100/0750PG/90R300	LER125/0750PG/90R300	LER150/0750PG/90R300
900	N/A	LER100/0900PG/90R300	LER125/0900PG/90R300	LER150/0900PG/90R300



60° external riser

Standard radius 300mm = R300, other radii R450, R600, R750 and R900 (made to order)

Finish: pre-galvanised = PG

Width mm	Light duty 50mm Deep	Medium duty 100mm Deep	Heavy duty 125mm Deep	Extra heavy duty 150mm Deep
150	LER050/0150PG/60R300	LER100/0150PG/60R300	LER125/0150PG/60R300	LER150/0150PG/60R300
300	LER050/0300PG/60R300	LER100/0300PG/60R300	LER125/0300PG/60R300	LER150/0300PG/60R300
450	LER050/0450PG/60R300	LER100/0450PG/60R300	LER125/0450PG/60R300	LER150/0450PG/60R300
600	N/A	LER100/0600PG/60R300	LER125/0600PG/60R300	LER150/0600PG/60R300
750	N/A	LER100/0750PG/60R300	LER125/0750PG/60R300	LER150/0750PG/60R300
900	N/A	LER100/0900PG/60R300	LER125/0900PG/60R300	LER150/0900PG/60R300



45° external riser

Standard radius 300mm = R300, other radii R450, R600, R750 and R900 (made to order)

Finish: pre-galvanised = PG

Width mm	Light duty 50mm Deep	Medium duty 100mm Deep	Heavy duty 125mm Deep	Extra heavy duty 150mm Deep
150	LER050/0150PG/45R300	LER100/0150PG/45R300	LER125/0150PG/45R300	LER150/0150PG/45R300
300	LER050/0300PG/45R300	LER100/0300PG/45R300	LER125/0300PG/45R300	LER150/0300PG/45R300
450	LER050/0450PG/45R300	LER100/0450PG/45R300	LER125/0450PG/45R300	LER150/0450PG/45R300
600	N/A	LER100/0600PG/45R300	LER125/0600PG/45R300	LER150/0600PG/45R300
750	N/A	LER100/0750PG/45R300	LER125/0750PG/45R300	LER150/0750PG/45R300
900	N/A	LER100/0900PG/45R300	LER125/0900PG/45R300	LER150/0900PG/45R300

**30° external riser**

Standard radius 300mm = R300, other radii R450, R600, R750 and R900 (made to order)

Finish: pre-galvanised = PG

Width mm	Light duty 50mm Deep	Medium duty 100mm Deep	Heavy duty 125mm Deep	Extra heavy duty 150mm Deep
150	LER050/0150PG/30R300	LER100/0150PG/30R300	LER125/0150PG/30R300	LER150/0150PG/30R300
300	LER050/0300PG/30R300	LER100/0300PG/30R300	LER125/0300PG/30R300	LER150/0300PG/30R300
450	LER050/0450PG/30R300	LER100/0450PG/30R300	LER125/0450PG/30R300	LER150/0450PG/30R300
600	N/A	LER100/0600PG/30R300	LER125/0600PG/30R300	LER150/0600PG/30R300
750	N/A	LER100/0750PG/30R300	LER125/0750PG/30R300	LER150/0750PG/30R300
900	N/A	LER100/0900PG/30R300	LER125/0900PG/30R300	LER150/0900PG/30R300

**90° internal riser**

Standard radius 300mm = R300, other radii R450, R600, R750 and R900 (made to order)

Finish: pre-galvanised = PG

Width mm	Light duty 50mm Deep	Medium duty 100mm Deep	Heavy duty 125mm Deep	Extra heavy duty 150mm Deep
150	LIR050/0150PG/90R300	LIR100/0150PG/90R300	LIR125/0150PG/90R300	LIR150/0150PG/90R300
300	LIR050/0300PG/90R300	LIR100/0300PG/90R300	LIR125/0300PG/90R300	LIR150/0300PG/90R300
450	LIR050/0450PG/90R300	LIR100/0450PG/90R300	LIR125/0450PG/90R300	LIR150/0450PG/90R300
600	N/A	LIR100/0600PG/90R300	LIR125/0600PG/90R300	LIR150/0600PG/90R300
750	N/A	LIR100/0750PG/90R300	LIR125/0750PG/90R300	LIR150/0750PG/90R300
900	N/A	LIR100/0900PG/90R300	LIR125/0900PG/90R300	LIR150/0900PG/90R300

**60° internal riser**

Standard radius 300mm = R300, other radii R450, R600, R750 and R900 (made to order)

Finish: pre-galvanised = PG

Width mm	Light duty 50mm Deep	Medium duty 100mm Deep	Heavy duty 125mm Deep	Extra heavy duty 150mm Deep
150	LIR050/0150PG/60R300	LIR100/0150PG/60R300	LIR125/0150PG/60R300	LIR150/0150PG/60R300
300	LIR050/0300PG/60R300	LIR100/0300PG/60R300	LIR125/0300PG/60R300	LIR150/0300PG/60R300
450	LIR050/0450PG/60R300	LIR100/0450PG/60R300	LIR125/0450PG/60R300	LIR150/0450PG/60R300
600	N/A	LIR100/0600PG/60R300	LIR125/0600PG/60R300	LIR150/0600PG/60R300
750	N/A	LIR100/0750PG/60R300	LIR125/0750PG/60R300	LIR150/0750PG/60R300
900	N/A	LIR100/0900PG/60R300	LIR125/0900PG/60R300	LIR150/0900PG/60R300

**45° internal riser**

Standard radius 300mm = R300, other radii R450, R600, R750 and R900 (made to order)

Finish: pre-galvanised = PG

Width mm	Light duty 50mm Deep	Medium duty 100mm Deep	Heavy duty 125mm Deep	Extra heavy duty 150mm Deep
150	LIR050/0150PG/45R300	LIR100/0150PG/45R300	LIR125/0150PG/45R300	LIR150/0150PG/45R300
300	LIR050/0300PG/45R300	LIR100/0300PG/45R300	LIR125/0300PG/45R300	LIR150/0300PG/45R300
450	LIR050/0450PG/45R300	LIR100/0450PG/45R300	LIR125/0450PG/45R300	LIR150/0450PG/45R300
600	N/A	LIR100/0600PG/45R300	LIR125/0600PG/45R300	LIR150/0600PG/45R300
750	N/A	LIR100/0750PG/45R300	LIR125/0750PG/45R300	LIR150/0750PG/45R300
900	N/A	LIR100/0900PG/45R300	LIR125/0900PG/45R300	LIR150/0900PG/45R300

**30° internal riser**

Standard radius 300mm = R300, other radii R450, R600, R750 and R900 (made to order)

Finish: pre-galvanised = PG

Width mm	Light duty 50mm Deep	Medium duty 100mm Deep	Heavy duty 125mm Deep	Extra heavy duty 150mm Deep
150	LIR050/0150PG/30R300	LIR100/0150PG/30R300	LIR125/0150PG/30R300	LIR150/0150PG/30R300
300	LIR050/0300PG/30R300	LIR100/0300PG/30R300	LIR125/0300PG/30R300	LIR150/0300PG/30R300
450	LIR050/0450PG/30R300	LIR100/0450PG/30R300	LIR125/0450PG/30R300	LIR150/0450PG/30R300
600	N/A	LIR100/0600PG/30R300	LIR125/0600PG/30R300	LIR150/0600PG/30R300
750	N/A	LIR100/0750PG/30R300	LIR125/0750PG/30R300	LIR150/0750PG/30R300
900	N/A	LIR100/0900PG/30R300	LIR125/0900PG/30R300	LIR150/0900PG/30R300

**Articulated riser**

Finish: pre-galvanised = PG

Width mm	Light duty 50mm Deep	Medium duty 100mm Deep	Heavy duty 125mm Deep	Extra heavy duty 150mm Deep
150	N/A	L/AR100/0150PG	L/AR125/0150PG	L/AR150/0150PG
300	N/A	L/AR100/0300PG	L/AR125/0300PG	L/AR150/0300PG
450	N/A	L/AR100/0450PG	L/AR125/0450PG	L/AR150/0450PG
600	N/A	L/AR100/0600PG	L/AR125/0600PG	L/AR150/0600PG
750	N/A	L/AR100/0750PG	L/AR125/0750PG	L/AR150/0750PG
900	N/A	L/AR100/0900PG	L/AR125/0900PG	L/AR150/0900PG







Covers

Cover – straight length – 1.5m long (and fixing clamps)

Finish: pre-galvanised = PG

Standard closed covers = C, ventilated cover = CV

Includes fixing clamps and fasteners, 2 covers required for 3m ladder, 4 covers for 6m ladder

Width mm		Extra fixing clamps Pack of 10 (includes fasteners)	
150	LSLC/0150PG/1.5	Closed cover clip	
300	LSLC/0300PG/1.5	L/CCCPG	
450	LSLC/0450PG/1.5		
600	LSLC/0600PG/1.5	Ventilated cover clip	
750	LSLC/0750PG/1.5	L/CCVPG	
900	LSLC/0900PG/1.5		

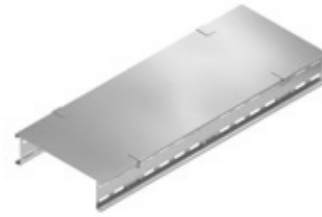

Cover – 90° flat bend

Standard radius 300mm = R300, other radii R450, R600, R750 and R900 (made to order).

Finish: pre-galvanised = PG

Standard closed covers = C, ventilated cover = CV

Includes fixing clamps and fasteners

Width mm	
150	LFBC/0150PG/90R300
300	LFBC/0300PG/90R300
450	LFBC/0450PG/90R300
600	LFBC/0600PG/90R300
750	LFBC/0750PG/90R300
900	LFBC/0900PG/90R300



Cover – 60° flat bend

Standard radius 300mm = R300, other radii R450, R600, R750 and R900 (made to order).

Finish: pre-galvanised = PG

Standard closed covers = C, ventilated cover = CV

Includes fixing clamps and fasteners

Width mm	
150	LFBC/0150PG/60R300
300	LFBC/0300PG/60R300
450	LFBC/0450PG/60R300
600	LFBC/0600PG/60R300
750	LFBC/0750PG/60R300
900	LFBC/0900PG/60R300



Cover – 45° flat bend

Standard radius 300mm = R300, other radii R450, R600, R750 and R900 (made to order).

Finish: pre-galvanised = PG

Standard closed covers = C, ventilated cover = CV

Includes fixing clamps and fasteners

Width mm	
150	LFBC/0150PG/45R300
300	LFBC/0300PG/45R300
450	LFBC/0450PG/45R300
600	LFBC/0600PG/45R300
750	LFBC/0750PG/45R300
900	LFBC/0900PG/45R300



Cover – 30° flat bend

Standard radius 300mm = R300, other radii R450, R600, R750 and R900 (made to order).

Finish: pre-galvanised = PG

Standard closed covers = C, ventilated cover = CV

Includes fixing clamps and fasteners

Width mm	
150	LFBC/0150PG/30R300
300	LFBC/0300PG/30R300
450	LFBC/0450PG/30R300
600	LFBC/0600PG/30R300
750	LFBC/0750PG/30R300
900	LFBC/0900PG/30R300



Cover – equal tee

Standard radius 300mm = R300, other radii R450, R600, R750 and R900 (made to order).

Finish: pre-galvanised = PG

Standard closed covers = C, ventilated cover = CV

Includes fixing clamps and fasteners

Width mm	
150	LETC/0150PGR300
300	LETC/0300PGR300
450	LETC/0450PGR300
600	LETC/0600PGR300
750	LETC/0750PGR300
900	LETC/0900PGR300



Cover – unequal tee (made to order)

Standard radius 300mm = R300, other radii R450, R600, R750 and R900 (made to order).

Finish: pre-galvanised = PG

Standard closed covers = C, ventilated cover = CV. Includes fixing clamps and fasteners

How to generate the part number – LUTC/W1/W2(finish)(radius)

Example – LUTC/0300/0150PGR300

Table below shows a complete list of W1 and W2 combinations.

W1	W2
150	300, 450, 600, 750, 900
300	150, 450, 600, 750, 900
450	150, 300, 600, 750, 900
600	150, 300, 450, 750, 900
750	150, 300, 450, 600, 900
900	150, 300, 450, 600, 750



Cover – crossover

Standard radius 300mm = R300, other radii R450, R600, R750 and R900 (made to order).

Finish: pre-galvanised = PG

Standard closed covers = C, ventilated cover = CV

Includes fixing clamps and fasteners

Width mm	
150	LCOC/0150PGR300
300	LCOC/0300PGR300
450	LCOC/0450PGR300
600	LCOC/0600PGR300
750	LCOC/0750PGR300
900	LCOC/0900PGR300



Cover – straight reducer

Finish: pre-galvanised = PG

Standard closed covers = C, ventilated cover = CV

Includes fixing clamps and fasteners

Width mm		
W1	W2	
300	150	LSRC100/0300/0150PG
450	150	LSRC100/0450/0150PG
600	150	LSRC100/0600/0150PG
750	150	LSRC100/0750/0150PG
900	150	LSRC100/0900/0150PG
450	300	LSRC100/0450/0300PG
600	300	LSRC100/0600/0300PG
750	300	LSRC100/0750/0300PG
900	300	LSRC100/0900/0300PG
600	450	LSRC100/0600/0450PG
750	450	LSRC100/0750/0450PG
900	450	LSRC100/0900/0450PG
750	600	LSRC100/0750/0600PG
900	600	LSRC100/0900/0600PG
900	750	LSRC100/0900/0750PG

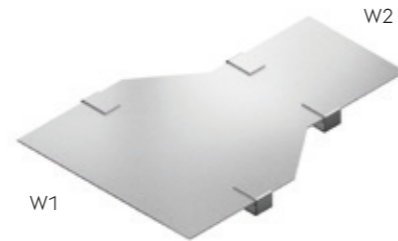
**Cover – right hand reducer**

Finish: pre-galvanised = PG

Standard closed covers = C, ventilated cover = CV

Includes fixing clamps and fasteners

Width mm		
W1	W2	
300	150	LRRC100/0300/0150PG
450	150	LRRC100/0450/0150PG
600	150	LRRC100/0600/0150PG
750	150	LRRC100/0750/0150PG
900	150	LRRC100/0900/0150PG
450	300	LRRC100/0450/0300PG
600	300	LRRC100/0600/0300PG
750	300	LRRC100/0750/0300PG
900	300	LRRC100/0900/0300PG
600	450	LRRC100/0600/0450PG
750	450	LRRC100/0750/0450PG
900	450	LRRC100/0900/0450PG
750	600	LRRC100/0750/0600PG
900	600	LRRC100/0900/0600PG
900	750	LRRC100/0900/0750PG

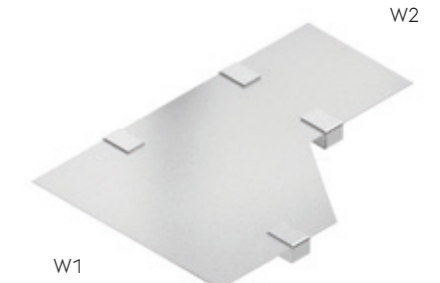
**Cover – left hand reducer**

Finish: pre-galvanised = PG

Standard closed covers = C, ventilated cover = CV

Includes fixing clamps and fasteners

Width mm		
W1	W2	
300	150	LLRC100/0300/0150PG
450	150	LLRC100/0450/0150PG
600	150	LLRC100/0600/0150PG
750	150	LLRC100/0750/0150PG
900	150	LLRC100/0900/0150PG
450	300	LLRC100/0450/0300PG
600	300	LLRC100/0600/0300PG
750	300	LLRC100/0750/0300PG
900	300	LLRC100/0900/0300PG
600	450	LLRC100/0600/0450PG
750	450	LLRC100/0750/0450PG
900	450	LLRC100/0900/0450PG
750	600	LLRC100/0750/0600PG
900	600	LLRC100/0900/0600PG
900	750	LLRC100/0900/0750PG

**Cover – 90° external riser**

Standard radius 300mm = R300, other radii R450, R600, R750 and R900 (Made to order)

Finish: pre-galvanised = PG

Standard closed covers = C, ventilated cover = CV

Includes fixing clamps and fasteners

Width mm	Light duty 50mm Deep	Medium duty 100mm Deep	Heavy duty 125mm Deep	Extra heavy duty 150mm Deep
150	LERC050/0150PG/90R300	LERC100/0150PG/90R300	LERC125/0150PG/90R300	LERC150/0150PG/90R300
300	LERC050/0300PG/90R300	LERC100/0300PG/90R300	LERC125/0300PG/90R300	LERC150/0300PG/90R300
450	LERC050/0450PG/90R300	LERC100/0450PG/90R300	LERC125/0450PG/90R300	LERC150/0450PG/90R300
600	N/A	LERC100/0600PG/90R300	LERC125/0600PG/90R300	LERC150/0600PG/90R300
750	N/A	LERC100/0750PG/90R300	LERC125/0750PG/90R300	LERC150/0750PG/90R300
900	N/A	LERC100/0900PG/90R300	LERC125/0900PG/90R300	LERC150/0900PG/90R300

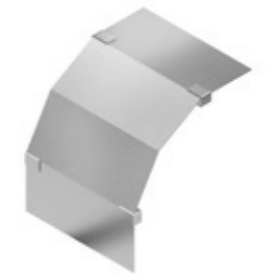
**Cover – 60° external riser**

Standard radius 300mm = R300, other radii R450, R600, R750 and R900 (Made to order)

Finish: pre-galvanised = PG

Standard closed covers = C, ventilated cover = CV

Includes fixing clamps and fasteners

Width mm	Light duty 50mm Deep	Medium duty 100mm Deep	Heavy duty 125mm Deep	Extra heavy duty 150mm Deep
150	LERC050/0150PG/60R300	LERC100/0150PG/60R300	LERC125/0150PG/60R300	LERC150/0150PG/60R300
300	LERC050/0300PG/60R300	LERC100/0300PG/60R300	LERC125/0300PG/60R300	LERC150/0300PG/60R300
450	LERC050/0450PG/60R300	LERC100/0450PG/60R300	LERC125/0450PG/60R300	LERC150/0450PG/60R300
600	N/A	LERC100/0600PG/60R300	LERC125/0600PG/60R300	LERC150/0600PG/60R300
750	N/A	LERC100/0750PG/60R300	LERC125/0750PG/60R300	LERC150/0750PG/60R300
900	N/A	LERC100/0900PG/60R300	LERC125/0900PG/60R300	LERC150/0900PG/60R300



Cover – 45° external riser

Standard radius 300mm = R300, other radii R450, R600, R750 and R900 (Made to order)

Finish: pre-galvanised = PG

Standard closed covers = C, ventilated cover = CV

Includes fixing clamps and fasteners

Width mm	Light duty 50mm Deep	Medium duty 100mm Deep	Heavy duty 125mm Deep	Extra heavy duty 150mm Deep
150	LERC050/0150PG/45R300	LERC100/0150PG/45R300	LERC125/0150PG/45R300	LERC150/0150PG/45R300
300	LERC050/0300PG/45R300	LERC100/0300PG/45R300	LERC125/0300PG/45R300	LERC150/0300PG/45R300
450	LERC050/0450PG/45R300	LERC100/0450PG/45R300	LERC125/0450PG/45R300	LERC150/0450PG/45R300
600	N/A	LERC100/0600PG/45R300	LERC125/0600PG/45R300	LERC150/0600PG/45R300
750	N/A	LERC100/0750PG/45R300	LERC125/0750PG/45R300	LERC150/0750PG/45R300
900	N/A	LERC100/0900PG/45R300	LERC125/0900PG/45R300	LERC150/0900PG/45R300

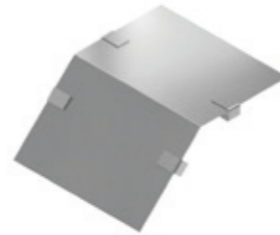
**Cover – 30° external riser**

Standard radius 300mm = R300, other radii R450, R600, R750 and R900 (Made to order)

Finish: pre-galvanised = PG

Standard closed covers = C, ventilated cover = CV

Includes fixing clamps and fasteners

Width mm	Light duty 50mm Deep	Medium duty 100mm Deep	Heavy duty 125mm Deep	Extra heavy duty 150mm Deep
150	LERC050/0150PG/30R300	LERC100/0150PG/30R300	LERC125/0150PG/30R300	LERC150/0150PG/30R300
300	LERC050/0300PG/30R300	LERC100/0300PG/30R300	LERC125/0300PG/30R300	LERC150/0300PG/30R300
450	LERC050/0450PG/30R300	LERC100/0450PG/30R300	LERC125/0450PG/30R300	LERC150/0450PG/30R300
600	N/A	LERC100/0600PG/30R300	LERC125/0600PG/30R300	LERC150/0600PG/30R300
750	N/A	LERC100/0750PG/30R300	LERC125/0750PG/30R300	LERC150/0750PG/30R300
900	N/A	LERC100/0900PG/30R300	LERC125/0900PG/30R300	LERC150/0900PG/30R300

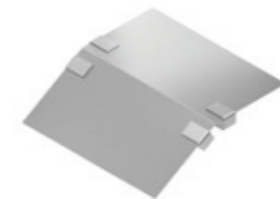
**Cover – 90° internal riser**

Standard radius 300mm = R300, other radii R450, R600, R750 and R900 (Made to order)

Finish: pre-galvanised = PG

Standard closed covers = C, ventilated cover = CV

Includes fixing clamps and fasteners

Width mm	
150	LIRC/0150PG/90R300
300	LIRC/0300PG/90R300
450	LIRC/0450PG/90R300
600	LIRC/0600PG/90R300
750	LIRC/0750PG/90R300
900	LIRC/0900PG/90R300

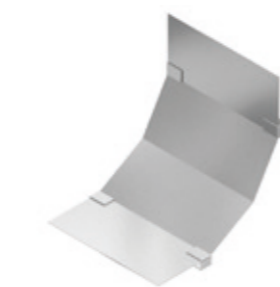
**Cover – 60° internal riser**

Standard radius 300mm = R300, other radii R450, R600, R750 and R900 (Made to order)

Finish: pre-galvanised = PG

Standard closed covers = C, ventilated cover = CV

Includes fixing clamps and fasteners

Width mm	
150	LIRC/0150PG/60R300
300	LIRC/0300PG/60R300
450	LIRC/0450PG/60R300
600	LIRC/0600PG/60R300
750	LIRC/0750PG/60R300
900	LIRC/0900PG/60R300

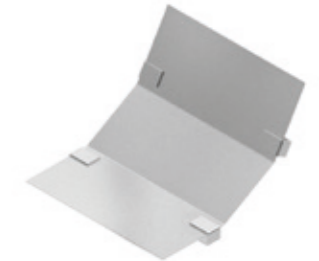
**Cover – 45° internal riser**

Standard radius 300mm = R300, other radii R450, R600, R750 and R900 (Made to order)

Finish: pre-galvanised = PG

Standard closed covers = C, ventilated cover = CV

Includes fixing clamps and fasteners

Width mm	
150	LIRC/0150PG/45R300
300	LIRC/0300PG/45R300
450	LIRC/0450PG/45R300
600	LIRC/0600PG/45R300
750	LIRC/0750PG/45R300
900	LIRC/0900PG/45R300

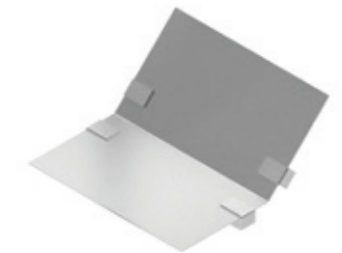
**Cover – 30° internal riser**

Standard radius 300mm = R300, other radii R450, R600, R750 and R900 (Made to order)

Finish: pre-galvanised = PG

Standard closed covers = C, ventilated cover = CV

Includes fixing clamps and fasteners

Width mm	
150	LIRC/0150PG/30R300
300	LIRC/0300PG/30R300
450	LIRC/0450PG/30R300
600	LIRC/0600PG/30R300
750	LIRC/0750PG/30R300
900	LIRC/0900PG/30R300

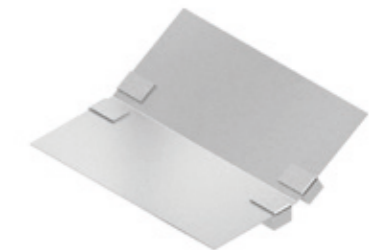

Accessories

Splice plates

Finish: pre-galvanised = PG

Ladder depth mm	Sold in pairs (includes 16 nuts, bolts and washers)
50	L/SSP50PGPR
100	L/SSP100PGPR
125	L/SSP125PGPR
150	L/SSP150PGPR

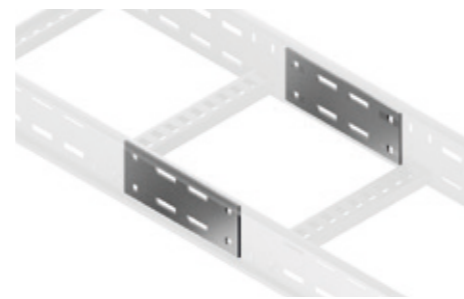

Vertical splice plates

Finish: pre-galvanised = PG

Ladder depth mm	Sold in pairs (includes 16 nuts, bolts and washers)
50	L/VSP50PGPR
100	L/VSP100PGPR
125	L/VSP125PGPR
150	L/VSP150PGPR



Hold down bracket

Finish: pre-galvanised = PG

Ladder depth mm	Sold as single item (fasteners excluded)
50	L/HDB50PG
100	L/HDB100PG
125	L/HDB125PG
150	L/HDB150PG



Suspension clip

Finish: pre-galvanised = PG
Slot diameter is 12mm x 20mm.

Ladder depth mm	Sold as single item (fasteners excluded)
50	L/SC50PG
100	L/SC100PG
125	L/SC125PG
150	L/SC150PG



Hold down clip

Finish: pre-galvanised = PG

Sold as single item (fasteners excluded)

L/HDC/APG



Bolted hold down clip

Finish: pre-galvanised = PG

Sold as single item (fasteners excluded)

L/HDC/BPG



Side rail clamp

Finish: pre-galvanised = PG

Sold as single item (fasteners excluded)

L/SRCPG

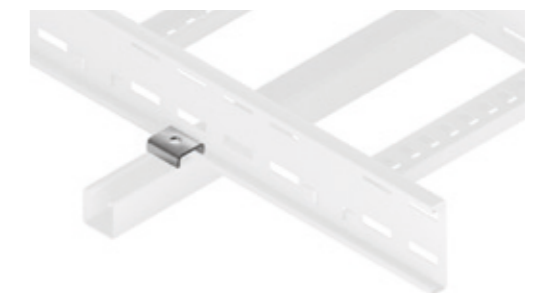

Bendable splice plates

Finish: pre-galvanised = PG

Ladder depth mm	Sold in pairs (includes 16 nuts, bolts and washers)
50	L/BSP050/PGPR
100	L/BSP100/PGPR
125	L/BSP125/PGPR
150	L/BSP150/PGPR

**End connectors**

Finish: pre-galvanised = PG

Ladder depth mm	Sold in pairs (fasteners excluded)
50	L/ECO50PGPR
100	L/ECO100PGPR
125	L/ECO125PGPR
150	L/ECO150PGPR

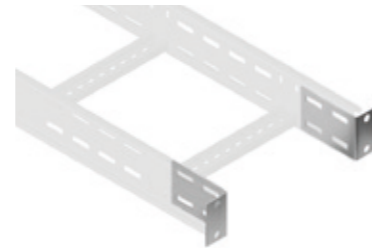
**Stop ends**

Finish: pre-galvanised = PG

Sold as single item (fasteners excluded)

Width mm	Light duty 50mm Deep	Medium duty 100mm Deep	Heavy duty 125mm Deep	Extra heavy duty 150mm Deep
150	L/SE050/0150PG	L/SE100/0150PG	L/SE125/0150PG	L/SE150/0150PG
300	L/SE050/0300PG	L/SE100/0300PG	L/SE125/0300PG	L/SE150/0300PG
450	L/SE050/0450PG	L/SE100/0450PG	L/SE125/0450PG	L/SE150/0450PG
600	N/A	L/SE100/0600PG	L/SE125/0600PG	L/SE150/0600PG
750	N/A	L/SE100/0750PG	L/SE125/0750PG	L/SE150/0750PG
900	N/A	L/SE100/0900PG	L/SE125/0900PG	L/SE150/0900PG

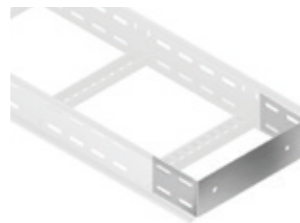
**Drop out plates**

Finish: pre-galvanised = PG

Ladder depth mm	Sold as single item (fasteners excluded)
150	L/DOP150PG
300	L/DOP300PG
450	L/DOP450PG
600	L/DOP600PG
750	L/DOP750PG
900	L/DOP900PG

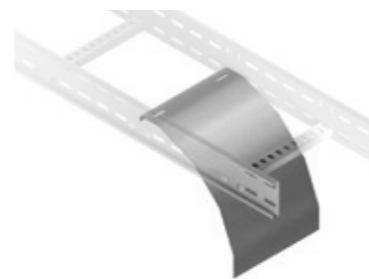
**Drop out brackets**

Finish: pre-galvanised = PG

Ladder depth mm	Sold in pairs (fasteners excluded)
50	N/A
100	L/RTR100PGPR
125	L/RTR125PGPR
150	L/RTR150PGPR

**Wall brackets**

Finish: pre-galvanised = PG

Ladder depth mm	Sold in pairs (fasteners excluded)
50	L/WSB050PGPR
100	L/WSB100PGPR
125	L/WSB125PGPR
150	L/WSB150PGPR

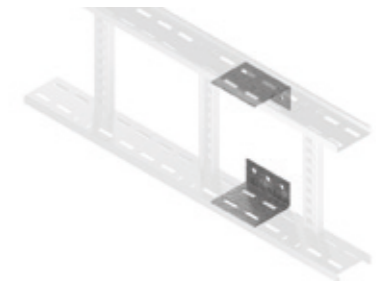
**Straight divider – 3m long**

Finish: pre-galvanised = PG

Ladder depth mm	Sold as single item (fasteners excluded)
50	LSD050/3PG
100	LSD100/3PG
125	LSD125/3PG
150	LSD150/3PG

**Bendable divider – 1m long**

Finish: pre-galvanised = PG

Ladder depth mm	Sold as single item (fasteners excluded)
50	LBD050/PG
100	LBD100/PG
125	LBD125/PG
150	LBD150/PG

**Earth straps**Finish: copper braid Electro Tinned – 16mm²

Hole diameter is 12mm.

250mm long (fasteners excluded)

L/ES250



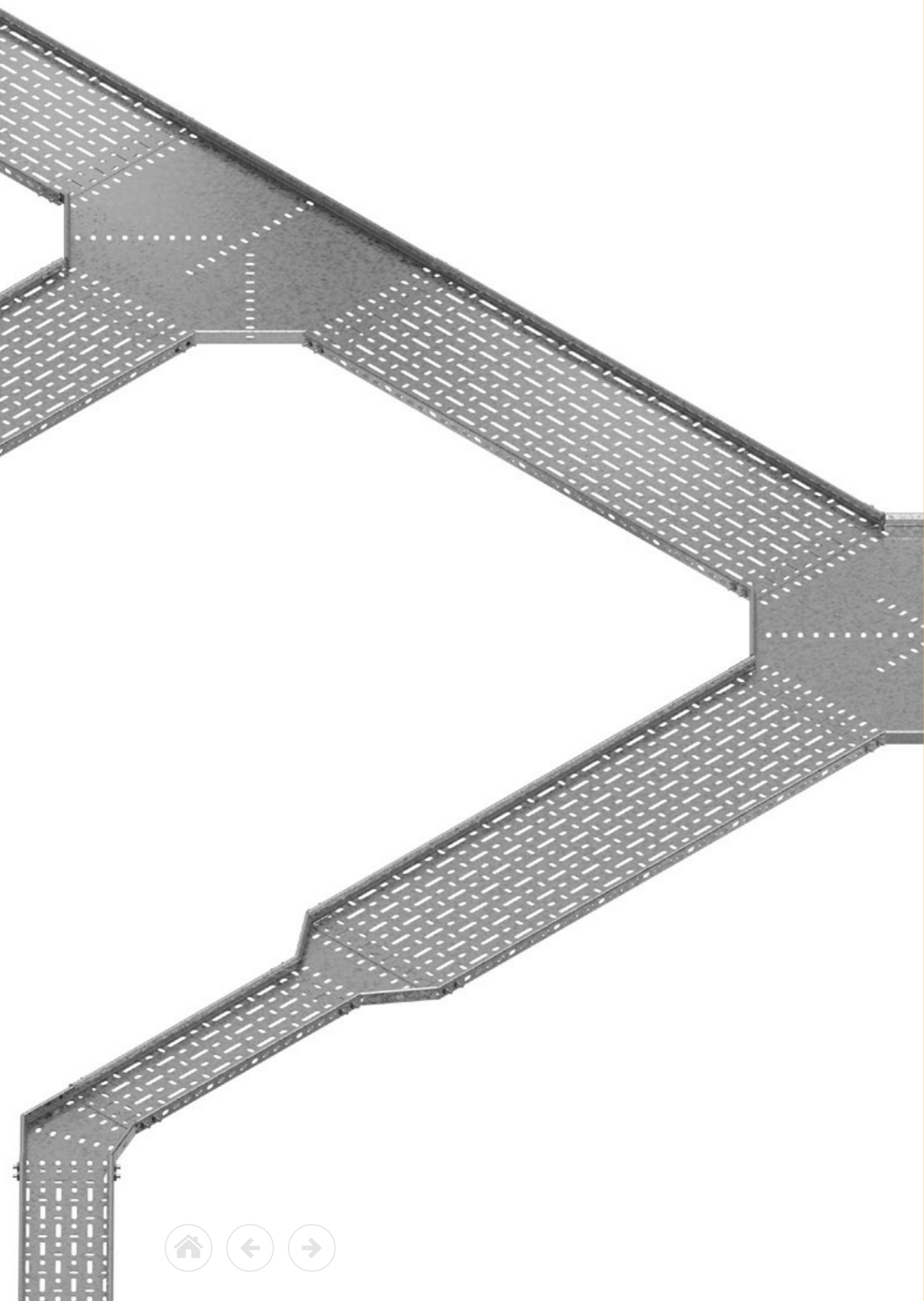

CABLE TRAY SYSTEMS



CABLE TRAY SYSTEMS

Metsec cable tray systems have been developed after significant consultation with major installers. This ensures the systems meet and surpass key requirements providing innovative and cost effective solutions in an increasingly demanding market.

The comprehensive Metsec cable tray range consists of three systems ranging from the light duty non-return flange cable tray to two systems with cable-friendly return flange trays, medium duty 25mm deep and heavy duty 50mm deep.

The unique perforation pattern allows ease of attachment of cables with more than adequate ventilation. The side walls of the medium and heavy duty ranges are also slotted as standard.

Light duty cable trays are available in widths of 50, 75, 100, 150, 225 and 300mm. Medium duty trays are available in widths of 50, 75, 100, 150, 225, 300, 450 and 600mm. Heavy duty trays are available in widths of 75, 100, 150, 225, 300, 450, 600, 750 and 900mm wide.

Each type of tray is a total system with a wide selection of support accessories to provide comprehensive site installation solutions.

Metsec cable trays are manufactured on sophisticated CNC equipment in a world class manufacturing cell engaging a high level of automation for fast moving items. This allows Metsec to maintain a very high level of on time in full delivery performance.

Comprehensive stocks of cable trays and accessories in both pre-galvanised and post hot dip galvanised finish are carried at all times to ensure timely delivery.

Development and testing

Metsec cable tray systems have been fully tested to develop accurate loading graphs. Further verification tests have also been done under the requirements of BS EN 61537 – Cable Management – cable tray systems and cable ladder systems. These tests include impact resistance, marking, connection of re-usable components, safe working load tests, electrical continuity, and performance of steel at extreme temperature ranges.

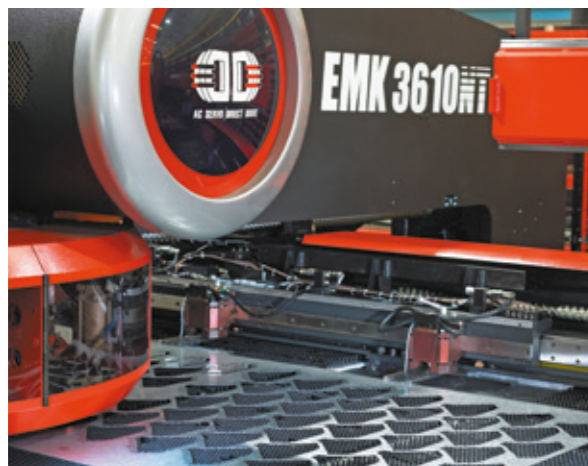

Loading graphs

Working loads are represented graphically as shown and are based on the cable tray being continuous over four spans or more. Deflection has been limited to SPAN/200 generally, based on the end span condition as the worst case. Deflection will be less than this on internal spans. However, on wider trays, additional deflection will be induced locally across the base of the tray, depending on the width of the tray and the load distribution across the width. This will not be detrimental to the structural performance of the tray but may need consideration if appearance is of prime importance.

Non-return flange – light duty

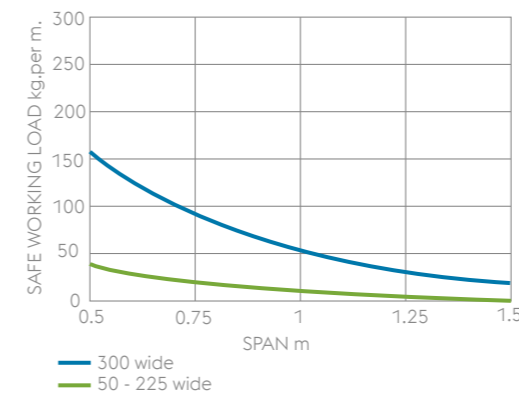

Bespoke systems

In addition to standard cable tray systems, Metsec has the ability to manufacture non standard cable tray systems to order.

Due to sophisticated equipment and software, prototypes can be produced quickly for sample approval.

It is important for customers to issue the complete order at the outset to allow full use of materials and avoid expensive waste.

Return flange – medium duty

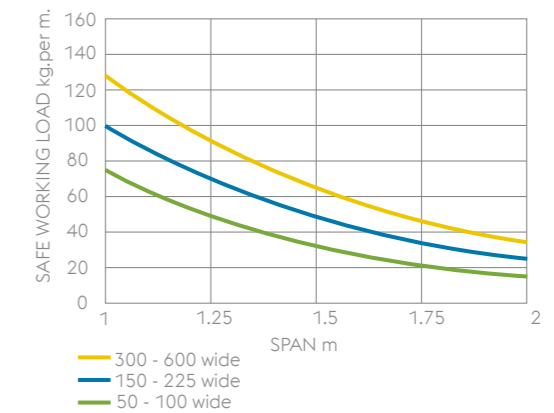

Return flange – heavy duty

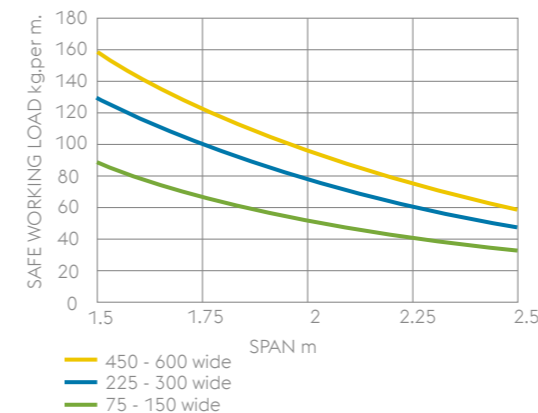

Loads not applicable to stainless steel, for stainless steel loads please consult the Technical Department for advice.

CABLE TRAY SYSTEMS

System Configuration and Support

Metsec cable trays are designed as a complete system with simple accessories. Integral connectors are included for bends tees etc. for all cable tray ranges.

When installing Metsec cable trays, care should be taken to ensure the support is within 600mm of a joint. Accessories (e.g. bends, tees, crossovers etc.) should have adequate support, additional support will be required for larger components. Light duty cable tray straights have one end swaged for easy connection to the next tray. When light duty straight trays are cut to smaller lengths on site, connection to the next tray requires fishplates.

Materials and Finishes

Materials and finishes available are mild steel pre-galvanised as standard, mild steel hot dip galvanised after manufacture and stainless steel grade 1.4404 (316L) to order.

Mild steel pre-galvanised: manufactured from steel complying with BS EN 10346

Mild steel hot dip galvanised: manufactured from steel complying with BS EN 10130 and hot dip galvanised after manufacture to BS EN ISO 1461

Stainless steel: manufactured from stainless steel grade 1.4404 (316L) complying with BS EN 10088-1 and BS EN 10088-2

Powder coating is available as an additional surface finish. Please provide the required RAL or BS colour and the level of Matt/Semi or Gloss when ordering.

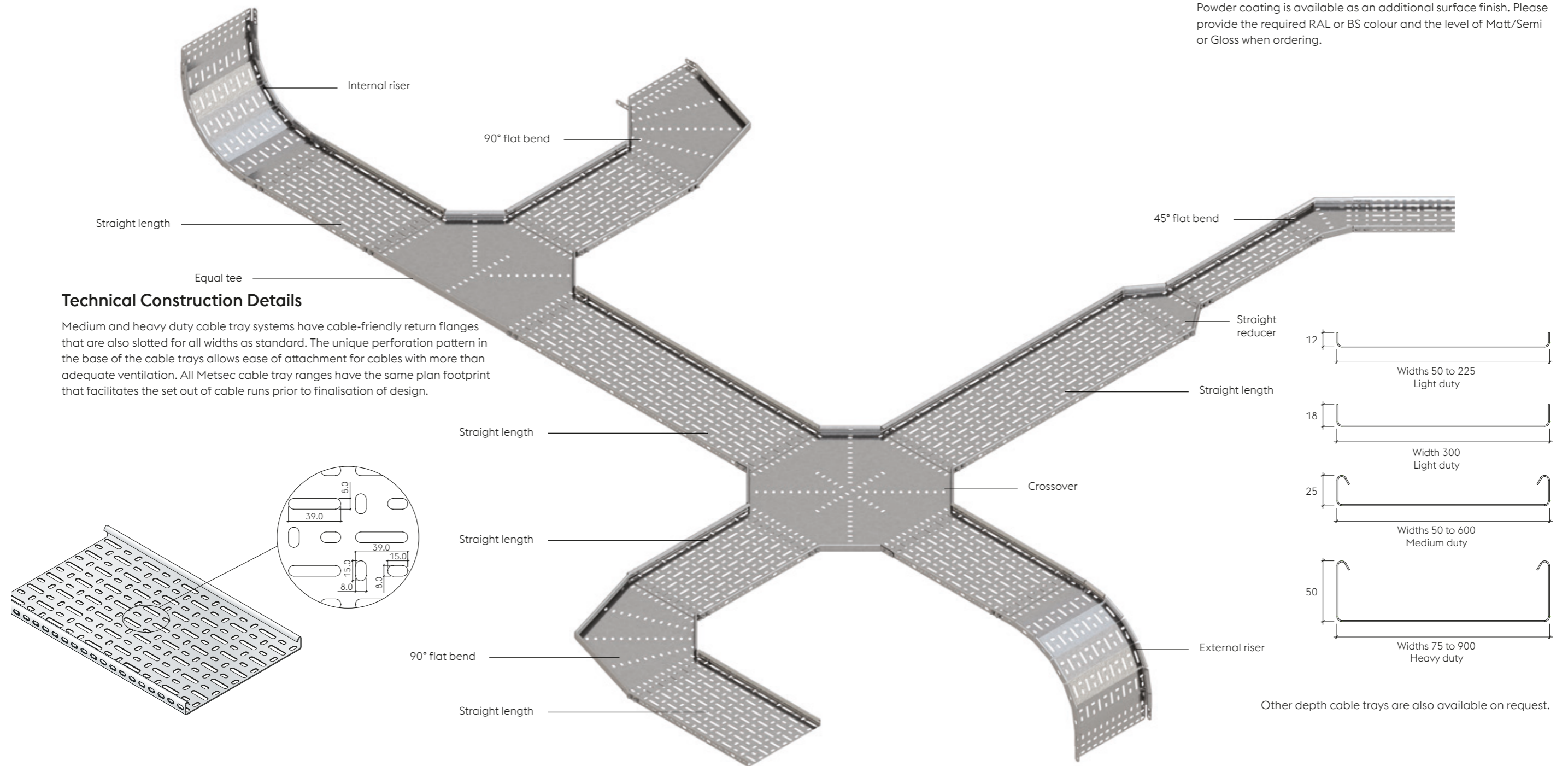

Technical Construction Details

Medium and heavy duty cable tray systems have cable-friendly return flanges that are also slotted for all widths as standard. The unique perforation pattern in the base of the cable trays allows ease of attachment for cables with more than adequate ventilation. All Metsec cable tray ranges have the same plan footprint that facilitates the set out of cable runs prior to finalisation of design.

Other depth cable trays are also available on request.

STANDARDS

Metsec cable tray systems generally conform to BS EN 61537 Cable Management – cable tray systems and cable ladder systems.

Information relating to compliance is detailed/highlighted within the following sections of the standard:

6 Classification

6.1 According to material	6.4 According to electrical conductivity
6.1.1 Metsec cable tray systems are metallic system components	6.4.1 Metsec cable tray systems are electrically conductive system components
6.2 According to resistance to flame propagation	6.5 According to resistance against corrosion
6.2.2 Metsec cable tray systems are non-flame propagating system components	6.5.2 Metsec cable tray systems are made of steel with metallic finishes or stainless steel
6.3 According to electrical continuity characteristics	(Resistance to corrosion is classified according to Table 1. and follow the relevant specification in Table 8, with compliance according to Table 7.)
6.3.2 Metsec cable tray systems have electrical continuity characteristics	

Table 1 – Classification for resistance against corrosion

Class	Reference – material and finish
0(a)	None
1	Electroplated to a minimum thickness of 5 µm
2	Electroplated to a minimum thickness of 12 µm
3	Pre-galvanised to grade 275 to BS EN 10346
4	Pre-galvanised to grade 350 to EN 10346
5	Post-galvanised to a zinc mean coating thickness (minimum) of 45 µm according to BS EN ISO 1461 for zinc thickness only
6	Post-galvanised to a zinc mean coating thickness (minimum) of 55 µm according to ISO 1461 for zinc thickness only
7	Post-galvanised to a zinc mean coating thickness (minimum) of 70 µm according to ISO 1461 for zinc thickness only
8	Post-galvanised to a zinc mean coating thickness (minimum) of 85 µm according to ISO 1461 for zinc thickness only
9A	Stainless steel manufactured to ASTM: A 240/A 240M – 95a designation S30400 or EN 10088 grade 1 – 4301 without a post treatment (b)
9B	Stainless steel manufactured to ASTM: A 240/A 240M – 95a designation S31603 or EN 10088 grade 1 – 4404 without a post treatment (b)
9C	Stainless steel manufactured to ASTM: A 240/A 240M – 95a designation S30400 or EN 10088 grade 1 – 4301 with a post treatment (b)
9D	Stainless steel manufactured to ASTM: A 240/A 240M – 95a designation S31603 or EN 10088 grade 1 – 4404 with a post treatment (b)
(a)	For materials which have no declared corrosion resistance classification
(b)	The post-treatment process is used to improve the protection against crevice crack corrosion and the contamination by other steels

Table 7 – System component compliance and classification for resistance against corrosion

System component Material and finishes	Classification according to	Compliance	Subclause for compliance check
Non-metallic	6.5.1	Declaration	14.2.1
Reference – zinc coating as in Table 1.	6.5.2 Table 1 classes 1 to 8	Declaration or measurement	14.2.2
Non-referenced zinc coating	6.5.2 Table 1 classes 1 to 8	By neutral salt spray test NSS	14.2.3
Reference – stainless steel as in Table 1.	6.5.2 Table 1 Class 9A to 9D	Declaration	14.2.2
Non-referenced stainless steel	Not classified	Declaration	None
Other metallic coatings	6.5.2 Table 1 Column 1 classes 1 to 8	By neutral salt spray test NSS	14.2.3
Aluminium alloys or other metals	6.5.3 Under consideration	Under consideration	14.2.4
Organic coatings	6.5.4 Under consideration	Under consideration	14.2.5

Table 8 – Zinc coating thickness of reference materials

Class	Minimum thickness	Minimum coating thickness as given in BS EN 10346	Mean coating thickness (minimum) to ISO 1461
	µm	µm	µm
0 (a)	-	-	-
1	5	-	-
2	12	-	-
3	-	13	-
4	-	17	-
5	-	-	45
3	-	-	55
4	-	-	70
5	-	-	85

a) As declared by the manufacturer or responsible vendor

- 6.6 According to temperature**
- 6.6.1 Minimum temperature for the system components is given in Table 2.
- 6.6.2 Maximum temperature for the system components is given in Table 3.
- 6.7 According to the free base area of the cable tray length as given in Table 4.**
- 6.9 According to impact resistance**
- 6.9.4 System component offering impact resistance up to 20 J (as verified by testing in accordance with 10.9 Test for impact resistance.)

7 Marking and Documentation

- 7.1 Each system component is marked by a label. Labels used fully comply with the rubbing test. Boxed items are labelled on the packaging

Table 2 – Minimum temperature classification

Minimum transport, storage installation and application temperature °C
+5
-5
-15
-20
-40
-50

Table 3 – Maximum temperature classification

Maximum transport, storage installation and application temperature °C
+40
+60
+90
+105
+120
+150

Table 4 – Perforation base classification

Classification	Perforation in the free base area
A	Up to 2%
B	Over 2% and up to 15%
C	Over 15% and up to 30%
D	More than 30 %

NB: Classification D relates to IEC 60364-5-52 Subclause A.52.6.2 second paragraph

8 Dimensions

Key cross sectional dimensions for straight cable tray

Part No	External depth mm	Internal depth mm	External width mm	Internal width mm	X-sectional area mm ²
CTSL12/0050	12	11.1	50	48.2	535.0
CTSL12/0075	12	11.1	75	73.2	812.5
CTSL12/0100	12	11.1	100	98.2	1090.0
CTSL12/0150	12	11.1	150	148.2	1645.0
CTSL12/0225	12	11.1	225	223.2	2477.5
CTSL18/0300	18	16.8	300	297.6	4999.7
CTSL25/0050	25	23.2	50	48.2	1118.2
CTSL25/0075	25	23.2	75	73.2	1698.2
CTSL25/0100	25	23.2	100	98.2	2278.2
CTSL25/0150	25	23.2	150	148.2	3438.2
CTSL25/0225	25	23.2	225	223.2	5178.2
CTSL25/0300	25	23.0	300	298.0	6854.0
CTSL25/0450	25	22.6	450	447.6	10115.8
CTSL25/0600	25	22.6	600	597.6	13505.8
CTSL50/0075	50	48.2	75	73.2	3528.2
CTSL50/0100	50	48.2	100	98.2	4733.2
CTSL50/0150	50	48.2	150	148.2	7143.2
CTSL50/0225	50	47.6	225	222.6	10595.8
CTSL50/0300	50	47.6	300	297.6	14165.8
CTSL50/0450	50	47.0	450	447.0	21009.0
CTSL50/0600	50	47.0	600	597.0	28059.0
CTSL50/0750	50	46.0	750	746.0	34316.0
CTSL50/0900	50	46.0	900	896.0	41216.0

Minimum internal radius of fittings

Minimal internal radius of fittings available for the accommodation of cables is 125mm.

9 Construction

- 9.1 Surfaces of system components which are likely to come into contact with cables during installation are inspected to ensure they shall not cause damage to the cables when installed correctly.
- 9.2 As with all metallic system components, care should be exercised that handling is in accordance with the relative COSHH regulations and gloves should be worn.
- 9.3 Screwed connections have been designed to withstand the mechanical stresses occurring during installations and normal use and will not cause damage to cables when correctly inserted. Screwed connections are in general ISO metric threads fully compliant to tests in accordance with 9.3.1 and 9.3.2 of the standard. Metsec cable tray systems are usually assembled using M6 roofing bolts particularly for couplers, fishplates and connection to supporting framework. These bolts should be tightened to a torque of 12N/m.

10 Mechanical Properties

Cable tray lengths have been tested generally in accordance with the standard under 10.2 and 10.3 for verification of the loading graphs. It should be noted that independent testing has been carried out to verify the structural performance of the cable trays at the minimum and maximum temperature classifications for test conditions under 10.2.2.

All accessories eg bends, tees etc. should be directly supported by a suitable support device or devices at appropriate positions.

CABLE TRAY SYSTEMS

Product Footprint

Cable tray – accessory foot print Standard radius is 125mm

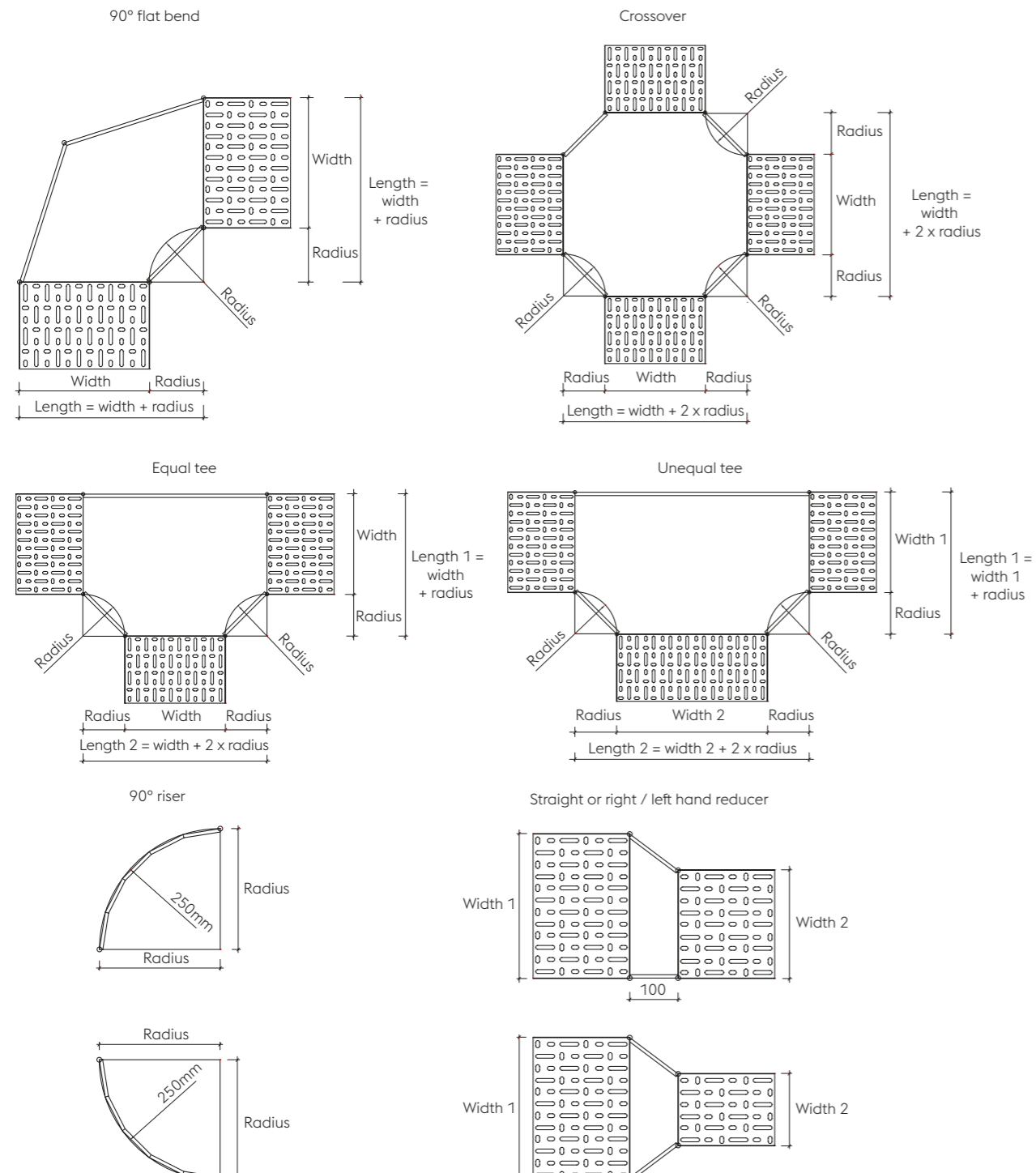

Straight Lengths & Couplers

Straight length

Finish: pre-galvanised = PG, post-galvanised = HDG, stainless steel grade 1.4404 (316L) = SS

Width mm	Light duty	Medium duty	Heavy duty
50	CTSL12/0050PG3	CTSL25/0050PG3	N/A
75	CTSL12/0075PG3	CTSL25/0075PG3	CTSL50/0075PG3
100	CTSL12/0100PG3	CTSL25/0100PG3	CTSL50/0100PG3
150	CTSL12/0150PG3	CTSL25/0150PG3	CTSL50/0150PG3
225	CTSL12/0225PG3	CTSL25/0225PG3	CTSL50/0225PG3
300	CTSL18/0300PG3	CTSL25/0300PG3	CTSL50/0300PG3
450	N/A	CTSL25/0450PG3	CTSL50/0450PG3
600	N/A	CTSL25/0600PG3	CTSL50/0600PG3
750	N/A	N/A	CTSL50/0750PG3
900	N/A	N/A	CTSL50/0900PG3

Medium Duty Straight Couplers

Only required for straight tray to straight tray connection – medium duty range.

Finish: post-galvanised = HDG, stainless steel grade 1.4404 (316L) = SS

Sold in pairs (Fasteners excluded)

CTSC25HDGPR

Not available in pre-galvanised

Medium Duty Wrap Over Couplers

Only required for straight tray to straight tray connection – medium duty range.

Finish: pre-galvanised = PG, post-galvanised = HDG, stainless steel grade 1.4404 (316L) = SS

Sold in pairs (Fasteners excluded)

CTC25PGPR

Medium Duty Quick Fix Coupler

Only required for straight tray to straight tray connection – medium duty range.

Finish: pre-galvanised = PG, post-galvanised = HDG, stainless steel grade 1.4404 (316L) = SS

Sold in pairs (Fasteners excluded)

CTCQ25PGPR

Heavy Duty Straight Couplers

Only required for straight tray to straight tray connection – heavy duty range.

Finish: post-galvanised = HDG, stainless steel grade 1.4404 (316L) = SS

Sold in pairs (Fasteners excluded)

CTSC50HDGPR

Not available in pre-galvanised

Heavy Duty Wrap Over Couplers

Only required for straight tray to straight tray connection – heavy duty range.

Finish: pre-galvanised = PG, post-galvanised = HDG, stainless steel grade 1.4404 (316L) = SS

Sold in pairs (Fasteners excluded)

CTC50PGPR

Heavy Duty Quick Fix Coupler

Only required for straight tray to straight tray connection – heavy duty range.

Finish: pre-galvanised = PG, post-galvanised = HDG, stainless steel grade 1.4404 (316L) = SS

Sold in pairs (Fasteners excluded)

CTCQ50PGPR



Flat Bends

90° flat bends

Finish: pre-galvanised = PG, post-galvanised = HDG, stainless steel grade 1.4404 (316L) = SS

Width mm	Light duty	Medium duty	Heavy duty
50	CTFB12/0050PG90	CTFB25/0050PG90	N/A
75	CTFB12/0075PG90	CTFB25/0075PG90	CTFB50/0075PG90
100	CTFB12/0100PG90	CTFB25/0100PG90	CTFB50/0100PG90
150	CTFB12/0150PG90	CTFB25/0150PG90	CTFB50/0150PG90
225	CTFB12/0225PG90	CTFB25/0225PG90	CTFB50/0225PG90
300	CTFB18/0300PG90	CTFB25/0300PG90	CTFB50/0300PG90
450	N/A	CTFB25/0450PG90	CTFB50/0450PG90
600	N/A	CTFB25/0600PG90	CTFB50/0600PG90
750	N/A	N/A	CTFB50/0750PG90
900	N/A	N/A	CTFB50/0900PG90



45° flat bends

Finish: pre-galvanised = PG, post-galvanised = HDG, stainless steel grade 1.4404 (316L) = SS

Width mm	Light duty	Medium duty	Heavy duty
50	CTFB12/0050PG45	CTFB25/0050PG45	N/A
75	CTFB12/0075PG45	CTFB25/0075PG45	CTFB50/0075PG45
100	CTFB12/0100PG45	CTFB25/0100PG45	CTFB50/0100PG45
150	CTFB12/0150PG45	CTFB25/0150PG45	CTFB50/0150PG45
225	CTFB12/0225PG45	CTFB25/0225PG45	CTFB50/0225PG45
300	CTFB18/0300PG45	CTFB25/0300PG45	CTFB50/0300PG45
450	N/A	CTFB25/0450PG45	CTFB50/0450PG45
600	N/A	CTFB25/0600PG45	CTFB50/0600PG45
750	N/A	N/A	CTFB50/0750PG45
900	N/A	N/A	CTFB50/0900PG45



Adjustable flat bend (made to order)

(Not available for light duty cable tray)

Finish: pre-galvanised = PG, post-galvanised = HDG, stainless steel grade 1.4404 (316L) = SS

Width mm	Medium duty	Heavy duty
50	CTAB25/0050PG	N/A
75	CTAB25/0075PG	CTAB50/0075PG
100	CTAB25/0100PG	CTAB50/0100PG
150	CTAB25/0150PG	CTAB50/0150PG
225	CTAB25/0225PG	CTAB50/0225PG
300	CTAB25/0300PG	CTAB50/0300PG

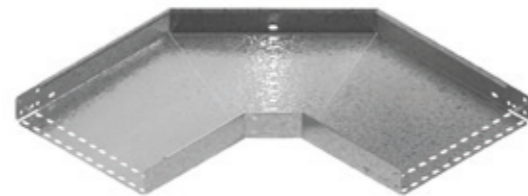

Tees

Equal tee

Finish: pre-galvanised = PG, post-galvanised = HDG, stainless steel grade 1.4404 (316L) = SS

Width mm	Light duty	Medium duty	Heavy duty
50	CTET12/0050PG	CTET25/0050PG	N/A
75	CTET12/0075PG	CTET25/0075PG	CTET50/0075PG
100	CTET12/0100PG	CTET25/0100PG	CTET50/0100PG
150	CTET12/0150PG	CTET25/0150PG	CTET50/0150PG
225	CTET12/0225PG	CTET25/0225PG	CTET50/0225PG
300	CTET18/0300PG	CTET25/0300PG	CTET50/0300PG
450	N/A	CTET25/0450PG	CTET50/0450PG
600	N/A	CTET25/0600PG	CTET50/0600PG
750	N/A	N/A	CTET50/0750PG
900	N/A	N/A	CTET50/0900PG

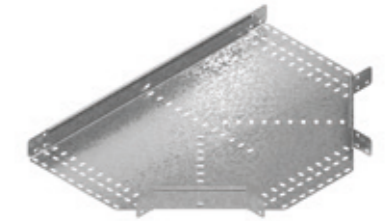

Unequal tee (made to order)

Finish: pre-galvanised = PG, post-galvanised = HDG, stainless steel grade 1.4404 (316L) = SS

How to generate the part number – CTUT(depth)/W1/W2(finish)

Example – CTUT50/300/150PG

Table below shows a complete list of W1 and W2 combinations.

W1	W2
50	75, 100, 150, 225, 300, 450, 600, 750, 900
75	50, 100, 150, 225, 300, 450, 600, 750, 900
100	50, 75, 150, 225, 300, 450, 600, 750, 900
150	50, 75, 100, 225, 300, 450, 600, 750, 900
225	50, 75, 100, 150, 300, 450, 600, 750, 900
300	50, 75, 100, 150, 225, 450, 600, 750, 900
450	50, 75, 100, 150, 225, 300, 600, 750, 900
600	50, 75, 100, 150, 225, 300, 450, 750, 900
750	50, 75, 100, 150, 225, 300, 450, 600, 900
900	50, 75, 100, 150, 225, 300, 450, 600, 750

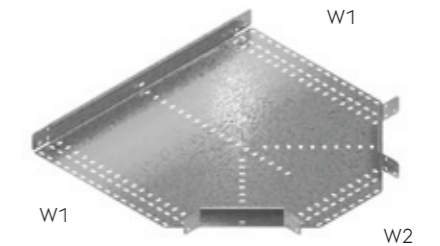

Crossovers, Risers & Reducers

Crossovers

Finish: pre-galvanised = PG, post-galvanised = HDG, stainless steel grade 1.4404 (316L) = SS

Width mm	Light duty	Medium duty	Heavy duty
50	CTCO12/0050PG	CTCO25/0050PG	N/A
75	CTCO12/0075PG	CTCO25/0075PG	CTCO50/0075PG
100	CTCO12/0100PG	CTCO25/0100PG	CTCO50/0100PG
150	CTCO12/0150PG	CTCO25/0150PG	CTCO50/0150PG
225	CTCO12/0225PG	CTCO25/0225PG	CTCO50/0225PG
300	CTCO18/0300PG	CTCO25/0300PG	CTCO50/0300PG
450	N/A	CTCO25/0450PG	CTCO50/0450PG
600	N/A	CTCO25/0600PG	CTCO50/0600PG
750	N/A	N/A	CTCO50/0750PG
900	N/A	N/A	CTCO50/0900PG (available upon request)

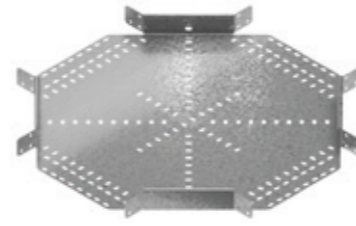

Internal riser – flexible

Finish: pre-galvanised = PG, post-galvanised = HDG, stainless steel grade 1.4404 (316L) = SS

CTFR = Flexible risers are supplied flat and folded on site to suit angle.

CTIR = Internal risers are folded to suit stated angle. 90 = 90°, 60 = 60°, 45 = 45°, 30 = 30°

Eg: CTIR50/0900PG90

Width mm	Light duty	Medium duty	Heavy duty
50	CTFR12/0050PG	CTFR25/0050PG	N/A
75	CTFR12/0075PG	CTFR25/0075PG	CTFR50/0075PG
100	CTFR12/0100PG	CTFR25/0100PG	CTFR50/0100PG
150	CTFR12/0150PG	CTFR25/0150PG	CTFR50/0150PG
225	CTFR12/0225PG	CTFR25/0225PG	CTFR50/0225PG
300	CTFR18/0300PG	CTFR25/0300PG	CTFR50/0300PG
450	N/A	CTFR25/0450PG	CTFR50/0450PG
600	N/A	CTFR25/0600PG	CTFR50/0600PG
750	N/A	N/A	CTIR50/0750PG90 (only available pre-folded)
900	N/A	N/A	CTIR50/0900PG90 (only available pre-folded)



External riser – flexible

Finish: pre-galvanised = PG, post-galvanised = HDG, stainless steel grade 1.4404 (316L) = SS

CTFR = Flexible risers are supplied flat and folded on site to suit angle.

CTER = External risers are folded to suit stated angle. 90 = 90°, 60 = 60°, 45 = 45°, 30 = 30°

E.g: CTER50/0900PG90

Width mm	Light duty	Medium duty	Heavy duty
50	CTFR12/0050PG	CTFR25/0050PG	N/A
75	CTFR12/0075PG	CTFR25/0075PG	CTFR50/0075PG
100	CTFR12/0100PG	CTFR25/0100PG	CTFR50/0100PG
150	CTFR12/0150PG	CTFR25/0150PG	CTFR50/0150PG
225	CTFR12/0225PG	CTFR25/0225PG	CTFR50/0225PG
300	CTFR18/0300PG	CTFR25/0300PG	CTFR50/0300PG
450	N/A	CTFR25/0450PG	CTFR50/0450PG
600	N/A	CTFR25/0600PG	CTFR50/0600PG
750	N/A	N/A	CTER50/0750PG90 (only available pre-folded)
900	N/A	N/A	CTER50/0900PG90 (only available pre-folded)



Reducers (made to order)

Finish: pre-galvanised = PG, post-galvanised = HDG, stainless steel grade 1.4404 (316L) = SS

For left hand reducers replace CTSR in part number with CTLR.

For right hand reducers replace CTSR in part number with CTRR.

Width mm		Light duty	Medium duty	Heavy duty
W1	W2			
75	50	CTSR12/0075/0050PG	CTSR25/0075/0050PG	N/A
100	50	CTSR12/0100/0050PG	CTSR25/0100/0050PG	N/A
150	50	CTSR12/0150/0050PG	CTSR25/0150/0050PG	N/A
225	50	CTSR12/0225/0050PG	CTSR25/0225/0050PG	N/A
300	50	CTSR18/0300/0050PG	CTSR25/0300/0050PG	N/A
450	50	N/A	CTSR25/0450/0050PG	N/A
600	50	N/A	CTSR25/0600/0050PG	N/A
750	50	N/A	N/A	N/A
900	50	N/A	N/A	N/A
100	75	CTSR12/0100/0075PG	CTSR25/0100/0075PG	CTSR50/0100/0075PG
150	75	CTSR12/0150/0075PG	CTSR25/0150/0075PG	CTSR50/0150/0075PG
225	75	CTSR12/0225/0075PG	CTSR25/0225/0075PG	CTSR50/0225/0075PG
300	75	N/A	CTSR25/0300/0075PG	CTSR50/0300/0075PG
450	75	N/A	CTSR25/0450/0075PG	CTSR50/0450/0075PG
600	75	N/A	CTSR25/0600/0075PG	CTSR50/0600/0075PG
750	75	N/A	N/A	CTSR50/0750/0075PG
900	75	N/A	N/A	CTSR50/0900/0075PG
150	100	CTSR12/0150/0100PG	CTSR25/0150/0100PG	CTSR50/0150/0100PG
225	100	CTSR12/0225/0100PG	CTSR25/0225/0100PG	CTSR50/0225/0100PG
300	100	N/A	CTSR25/0300/0100PG	CTSR50/0300/0100PG
450	100	N/A	CTSR25/0450/0100PG	CTSR50/0450/0100PG
600	100	N/A	CTSR25/0600/0100PG	CTSR50/0600/0100PG
750	100	N/A	N/A	CTSR50/0750/0100PG
900	100	N/A	N/A	CTSR50/0900/0100PG
225	150	CTSR12/0225/0150PG	CTSR25/0225/0150PG	CTSR50/0225/0150PG
300	150	N/A	CTSR25/0300/0150PG	CTSR50/0300/0150PG
450	150	N/A	CTSR25/0450/0150PG	CTSR50/0450/0150PG
600	150	N/A	CTSR25/0600/0150PG	CTSR50/0600/0150PG
750	150	N/A	N/A	CTSR50/0750/0150PG
900	150	N/A	N/A	CTSR50/0900/0150PG
300	225	N/A	CTSR25/0300/0225PG	CTSR50/0300/0225PG
450	225	N/A	CTSR25/0450/0225PG	CTSR50/0450/0225PG
600	225	N/A	CTSR25/0600/0225PG	CTSR50/0600/0225PG
750	225	N/A	N/A	CTSR50/0750/0225PG
900	225	N/A	N/A	CTSR50/0900/0225PG
450	300	N/A	CTSR25/0450/0300PG	CTSR50/0450/0300PG
600	300	N/A	CTSR25/0600/0300PG	CTSR50/0600/0300PG
750	300	N/A	N/A	CTSR50/0750/0300PG
900	300	N/A	N/A	CTSR50/0900/0300PG
600	450	N/A	CTSR25/0600/0450PG	CTSR50/0600/0450PG
750	450	N/A	N/A	CTSR50/0750/0450PG
900	450	N/A	N/A	CTSR50/0900/0450PG
750	600	N/A	N/A	CTSR50/0750/0600PG
900	600	N/A	N/A	CTSR50/0900/0600PG
900	750	N/A	N/A	CTSR50/0900/0750PG

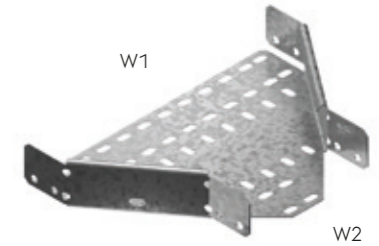

Fishplate couplers

Always required for cut lengths of light duty tray

Finish: pre-galvanised = PG, post-galvanised = HDG, stainless steel grade 1.4404 (316L) = SS

Width mm	(always required for cut lengths of light duty tray)
50	CTFP050PG
75	CTFP075PG
100	CTFP100PG
125	CTFP125PG
150	CTFP150PG
225	CTFP225PG
300	CTFP300PG
450	CTFP450PG
600	CTFP600PG
750	CTFP750PG
900	CTFP900PG

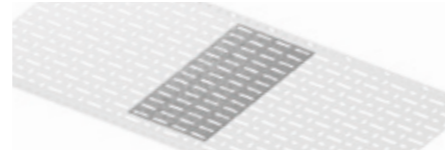
**90° flat bend covers (made to order)**

Finish: pre-galvanised = PG, post-galvanised = HDG, stainless steel grade 1.4404 (316L) = SS

Standard closed covers = CC, ventilated cover = CV

Includes 5 fixing clamps and fasteners

Width mm	Light duty	Medium duty	Heavy duty
50	CTFB12CV/050PG90	CTFB25CC/050PG90	N/A
75	CTFB12CV/075PG90	CTFB25CC/075PG90	CTFB50CC/075PG90
100	CTFB12CV/100PG90	CTFB25CC/100PG90	CTFB50CC/100PG90
150	CTFB12CV/150PG90	CTFB25CC/150PG90	CTFB50CC/150PG90
225	CTFB12CV/225PG90	CTFB25CC/225PG90	CTFB50CC/225PG90
300	CTFB18CV/300PG90	CTFB25CC/300PG90	CTFB50CC/300PG90
450	N/A	CTFB25CC/450PG90	CTFB50CC/450PG90
600	N/A	CTFB25CC/600PG90	CTFB50CC/600PG90
750	N/A	N/A	CTFB50CC/750PG90
900	N/A	N/A	CTFB50CC/900PG90

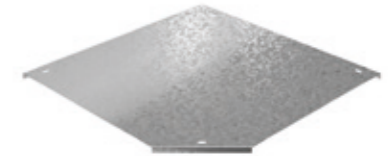

*NB: Closed cover not available for 12mm and 18mm deep cable tray.

Covers**Straight length covers – 3m long (made to order)**

Finish: pre-galvanised = PG, post-galvanised = HDG, stainless steel grade 1.4404 (316L) = SS

Standard closed covers = CC, ventilated cover = CV

Includes 6 fixing clamps and fasteners

Width mm	Light duty	Medium duty	Heavy duty
50	CTSL12CV/050PG	CTSL25CC/050PG	N/A
75	CTSL12CV/075PG	CTSL25CC/075PG	CTSL50CC/075PG
100	CTSL12CV/100PG	CTSL25CC/100PG	CTSL50CC/100PG
150	CTSL12CV/150PG	CTSL25CC/150PG	CTSL50CC/150PG
225	CTSL12CV/225PG	CTSL25CC/225PG	CTSL50CC/225PG
300	CTSL18CV/300PG	CTSL25CC/300PG	CTSL50CC/300PG
450	N/A	CTSL25CC/450PG	CTSL50CC/450PG
600	N/A	CTSL25CC/600PG	CTSL50CC/600PG
750	N/A	N/A	CTSL50CC/750PG
900	N/A	N/A	CTSL50CC/900PG



*NB: Closed cover not available for 12mm and 18mm deep cable tray.

Extra cover clips

Finish: pre-galvanised = PG, post-galvanised = HDG, stainless steel grade 316 = SS

Standard closed covers = CC, ventilated cover = CV

Duty	Standard	Ventilated
Light	N/A	CTCCV18HDG
Medium	CTCCC25HDG	CTCCV25HDG
Heavy	CTCCC50HDG	CTCCV50HDG

**45° flat bend covers (made to order)**

Finish: pre-galvanised = PG, post-galvanised = HDG, stainless steel grade 316 = SS

Standard closed covers = CC, ventilated cover = CV

Includes 5 fixing clamps and fasteners

Width mm	Light duty	Medium duty	Heavy duty
50	CTFB12CV/050PG45	CTFB25CC/050PG45	N/A
75	CTFB12CV/075PG45	CTFB25CC/075PG45	CTFB50CC/075PG45
100	CTFB12CV/100PG45	CTFB25CC/100PG45	CTFB50CC/100PG45
150	CTFB12CV/150PG45	CTFB25CC/150PG45	CTFB50CC/150PG45
225	CTFB12CV/225PG45	CTFB25CC/225PG45	CTFB50CC/225PG45
300	CTFB18CV/300PG45	CTFB25CC/300PG45	CTFB50CC/300PG45
450	N/A	CTFB25CC/450PG45	CTFB50CC/450PG45
600	N/A	CTFB25CC/600PG45	CTFB50CC/600PG45
750	N/A	N/A	CTFB50CC/750PG45
900	N/A	N/A	CTFB50CC/900PG45

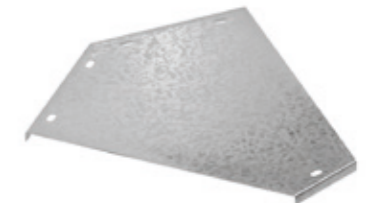

*NB: Closed cover not available for 12mm and 18mm deep cable tray.

Equal tee covers (made to order)

Finish: pre-galvanised = PG, post-galvanised = HDG, stainless steel grade 1.4404 (316L) = SS
Standard closed covers = CC, ventilated cover = CV
Includes 5 fixing clamps and fasteners

Width mm	Light duty	Medium duty	Heavy duty
50	CTET12CV/050PG	CTET25CC/050PG	N/A
75	CTET12CV/075PG	CTET25CC/075PG	CTET50CC/075PG
100	CTET12CV/100PG	CTET25CC/100PG	CTET50CC/100PG
150	CTET12CV/150PG	CTET25CC/150PG	CTET50CC/150PG
225	CTET12CV/225PG	CTET25CC/225PG	CTET50CC/225PG
300	CTET18CV/300PG	CTET25CC/300PG	CTET50CC/300PG
450	N/A	CTET25CC/450PG	CTET50CC/450PG
600	N/A	CTET25CC/600PG	CTET50CC/600PG
750	N/A	N/A	CTET50CC/750PG
900	N/A	N/A	CTET50CC/900PG

*NB: Closed cover not available for 12mm and 18mm deep cable tray.

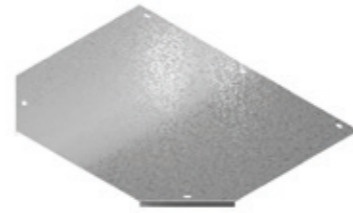
**Crossover covers (made to order)**

Finish: pre-galvanised = PG, post-galvanised = HDG, stainless steel grade 1.4404 (316L) = SS
Standard closed covers = CC, ventilated cover = CV
Includes 4 fixing clamps and fasteners

Width mm	Light duty	Medium duty	Heavy duty
50	CTCO12CV/050PG	CTCO25CC/050PG	N/A
75	CTCO12CV/075PG	CTCO25CC/075PG	CTCO50CC/075PG
100	CTCO12CV/100PG	CTCO25CC/100PG	CTCO50CC/100PG
150	CTCO12CV/150PG	CTCO25CC/150PG	CTCO50CC/150PG
225	CTCO12CV/225PG	CTCO25CC/225PG	CTCO50CC/225PG
300	CTCO18CV/300PG	CTCO25CC/300PG	CTCO50CC/300PG
450	N/A	CTCO25CC/450PG	CTCO50CC/450PG
600	N/A	CTCO25CC/600PG	CTCO50CC/600PG
750	N/A	N/A	CTCO50CC/750PG
900	N/A	N/A	CTCO50CC/900PG

*NB: Closed cover not available for 12mm and 18mm deep cable tray.

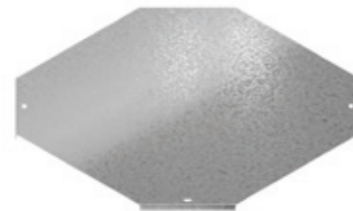
**Unequal tee covers (made to order)**

Finish: pre-galvanised = PG, post-galvanised = HDG, stainless steel grade 1.4404 (316L) = SS
Standard closed covers = CC, ventilated cover = CV
Includes 5 fixing clamps and fasteners

How to generate the part number – CTUT(cover type)W1/W2(finish)

Example – CTUTC/0300/0150PG

Table below shows a complete list of W1 and W2 combinations.

W1	W2
50	75, 100, 150, 225, 300, 450, 600, 750, 900
75	50, 100, 150, 225, 300, 450, 600, 750, 900
100	50, 75, 150, 225, 300, 450, 600, 750, 900
150	50, 75, 100, 225, 300, 450, 600, 750, 900
225	50, 75, 100, 150, 300, 450, 600, 750, 900
300	50, 75, 100, 150, 225, 450, 600, 750, 900
450	50, 75, 100, 150, 225, 300, 600, 750, 900
600	50, 75, 100, 150, 225, 300, 450, 750, 900
750	50, 75, 100, 150, 225, 300, 450, 600, 900
900	50, 75, 100, 150, 225, 300, 450, 600, 750

*NB: Closed cover not available for 12mm and 18mm deep cable tray.

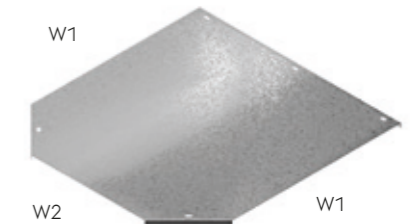

Reducer covers (made to order)

Finish: pre-galvanised = PG, post-galvanised = HDG, stainless steel grade 1.4404 (316L) = SS
Standard closed covers = CC, ventilated cover = CV
Includes 4 fixing clamps and fasteners

For left hand reducer covers replace CTSR in part number with CTLR.
For right hand reducer covers replace CTSR in part number with CTRR.

Width mm		Light duty	Medium duty	Heavy duty
W1	W2			
75	50	CTSRCV12/0075/0050PG	CTSRCC25/0075/0050PG	N/A
100	50	CTSRCV12/0100/0050PG	CTSRCC25/0100/0050PG	N/A
150	50	CTSRCV12/0150/0050PG	CTSRCC25/0150/0050PG	N/A
225	50	CTSRCV12/0225/0050PG	CTSRCC25/0225/0050PG	N/A
300	50	N/A	CTSRCC25/0300/0050PG	N/A
450	50	N/A	CTSRCC25/0450/0050PG	N/A
600	50	N/A	CTSRCC25/0600/0050PG	N/A
750	50	N/A	N/A	N/A
900	50	N/A	N/A	N/A
100	75	CTSRCV12/0100/0075PG	CTSRCC25/0100/0075PG	CTSRCC50/0100/0075PG
150	75	CTSRCV12/0150/0075PG	CTSRCC25/0150/0075PG	CTSRCC50/0150/0075PG
225	75	CTSRCV12/0225/0075PG	CTSRCC25/0225/0075PG	CTSRCC50/0225/0075PG
300	75	N/A	CTSRCC25/0300/0075PG	CTSRCC50/0300/0075PG
450	75	N/A	CTSRCC25/0450/0075PG	CTSRCC50/0450/0075PG
600	75	N/A	CTSRCC25/0600/0075PG	CTSRCC50/0600/0075PG
750	75	N/A	N/A	CTSRCC50/0750/0075PG
900	75	N/A	N/A	CTSRCC50/0900/0075PG
150	100	CTSRCV12/0150/0100PG	CTSRCC25/0150/0100PG	CTSRCC50/0150/0100PG
225	100	CTSRCV12/0225/0100PG	CTSRCC25/0225/0100PG	CTSRCC50/0225/0100PG
300	100	N/A	CTSRCC25/0300/0100PG	CTSRCC50/0300/0100PG
450	100	N/A	CTSRCC25/0450/0100PG	CTSRCC50/0450/0100PG
600	100	N/A	CTSRCC25/0600/0100PG	CTSRCC50/0600/0100PG
750	100	N/A	N/A	CTSRCC50/0750/0100PG
900	100	N/A	N/A	CTSRCC50/0900/0100PG
225	150	CTSRCV12/0225/0150PG	CTSRCC25/0225/0150PG	CTSRCC50/0225/0150PG
300	150	N/A	CTSRCC25/0300/0150PG	CTSRCC50/0300/0150PG
450	150	N/A	CTSRCC25/0450/0150PG	CTSRCC50/0450/0150PG
600	150	N/A	CTSRCC25/0600/0150PG	CTSRCC50/0600/0150PG
750	150	N/A	N/A	CTSRCC50/0750/0150PG
900	150	N/A	N/A	CTSRCC50/0900/0150PG
300	225	N/A	CTSRCC25/0300/0225PG	CTSRCC50/0300/0225PG
450	225	N/A	CTSRCC25/0450/0225PG	CTSRCC50/0450/0225PG
600	225	N/A	CTSRCC25/0600/0225PG	CTSRCC50/0600/0225PG
750	225	N/A	N/A	CTSRCC50/0750/0225PG
900	225	N/A	N/A	CTSRCC50/0900/0225PG
450	300	N/A	CTSRCC25/0450/0300PG	CTSRCC50/0450/0300PG
600	300	N/A	CTSRCC25/0600/0300PG	CTSRCC50/0600/0300PG
750	300	N/A	N/A	CTSRCC50/0750/0300PG
900	300	N/A	N/A	CTSRCC50/0900/0300PG
600	450	N/A	CTSRCC25/0600/0450PG	CTSRCC50/0600/0450PG
750	450	N/A	N/A	CTSRCC50/0750/0450PG
900	450	N/A	N/A	CTSRCC50/0900/0450PG
750	600	N/A	N/A	CTSRCC50/0750/0600PG
900	600	N/A	N/A	CTSRCC50/0900/0600PG
900	750	N/A	N/A	CTSRCC50/0900/0750PG

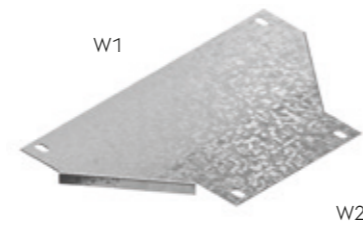
**90° internal riser covers (made to order)**

Finish: pre-galvanised = PG, post-galvanised = HDG, stainless steel grade 1.4404 (316L) = SS
Standard closed covers = CC, ventilated cover = CV
Includes 8 fixing clamps and fasteners

Width mm	Light duty	Medium duty	Heavy duty
50	CTIR12CV/0050PG90	CTIR25CC/0050PG90	N/A
75	CTIR12CV/0075PG90	CTIR25CC/0075PG90	CTIR50CC/0075PG90
100	CTIR12CV/0100PG90	CTIR25CC/0100PG90	CTIR50CC/0100PG90
150	CTIR12CV/0150PG90	CTIR25CC/0150PG90	CTIR50CC/0150PG90
225	CTIR12CV/0225PG90	CTIR25CC/0225PG90	CTIR50CC/0225PG90
300	CTIR18CV/0300PG90	CTIR25CC/0300PG90	CTIR50CC/0300PG90
450	N/A	CTIR25CC/0450PG90	CTIR50CC/0450PG90
600	N/A	CTIR25CC/0600PG90	CTIR50CC/0600PG90
750	N/A	N/A	CTIR50CC/0750PG90
900	N/A	N/A	CTIR50CC/0900PG90

*NB: Closed cover not available for 12mm and 18mm deep cable tray.

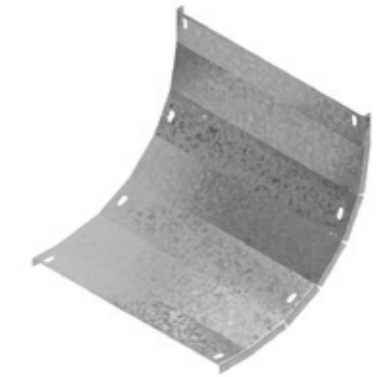
**90° external riser covers (made to order)**

Finish: pre-galvanised = PG, post-galvanised = HDG, stainless steel grade 1.4404 (316L) = SS
Standard closed covers = CC, ventilated cover = CV
Includes 8 fixing clamps and fasteners

Width mm	Light duty	Medium duty	Heavy duty
50	CTER12CV/0050PG90	CTER25CC/0050PG90	N/A
75	CTER12CV/0075PG90	CTER25CC/0075PG90	CTER50CC/0075PG90
100	CTER12CV/0100PG90	CTER25CC/0100PG90	CTER50CC/0100PG90
150	CTER12CV/0150PG90	CTER25CC/0150PG90	CTER50CC/0150PG90
225	CTER12CV/0225PG90	CTER25CC/0225PG90	CTER50CC/0225PG90
300	CTER18CV/0300PG90	CTER25CC/0300PG90	CTER50CC/0300PG90
450	N/A	CTER25CC/0450PG90	CTER50CC/0450PG90
600	N/A	CTER25CC/0600PG90	CTER50CC/0600PG90
750	N/A	N/A	CTER50CC/0750PG90
900	N/A	N/A	CTER50CC/0900PG90

*NB: Closed cover not available for 12mm and 18mm deep cable tray.

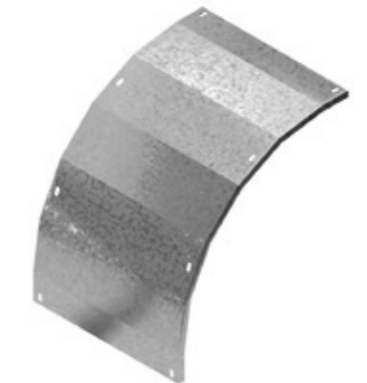

*NB: Closed cover not available for 12mm and 18mm deep cable tray.

Accessories

Stand off brackets

Finish: pre-galvanised = PG, post-galvanised = HDG, stainless steel grade 316 = SS

Width mm	
50	CTSO050PG
100	CTSO075PG
125	CTSO100PG
150	CTSO150PG
225	CTSO225PG
300	CTSO300PG
450	CTSO450PG
600	CTSO600PG
750	CTSO750PG
900	CTSO900PG

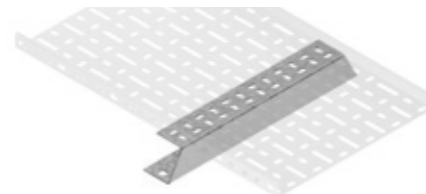

Hanger brackets

Finish: pre-galvanised = PG, post-galvanised = HDG, stainless steel grade 1.4404 (316L) = SS

Width mm	
50	CTHB050/PG
75	CTHB075/PG
100	CTHB100/PG
150	CTHB150/PG



Hanger Brackets – G Type

Width mm	
50	CTHB050/PG/SPL
75	CTHB075/PG/SPL
100	CTHB100/PG/SPL
150	CTHB150/PG/SPL
225	CTHB225/PG/SPL
300	CTHB300/PG/SPL

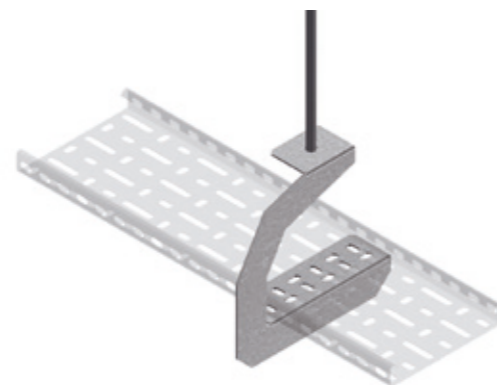

Straight divider – 3m

Finish: pre-galvanised = PG, post-galvanised = HDG, stainless steel grade 1.4404 (316L) = SS

Tray depth mm	
25	CTDI025PG3
50	CTDI050PG3

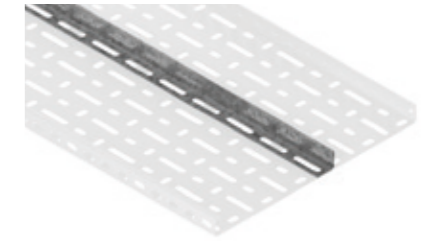

Earthing straps

Finish: electro-tinned

Supplied in packs of 10

CT/ES100

Copper braid electro tinned 4mm², 100mm long (use M6 x 12 roofing bolts)



Roofing bolts and nuts

Finish: BZP as standard, stainless steel grade 1.4404 (316L) = SS, post-galvanised = HDG

M6 x 12 roofing bolts

Supplied in packs of 100

M06X12RB





CABLE TRUNKING SYSTEMS

CABLE TRUNKING SYSTEMS

Metsec cable trunking systems meet the requirements of a demanding electrical installations market. Utilising world class production methods Metsec are able to offer competitive solutions to a high level of service.

The comprehensive Metsec cable trunking ranges consist of standard distribution trunking and lighting trunking.

Standard distribution trunking is available in widths and depths up to 300mm as standard. Lids are attached by turnbuckle fixings, with screw fix and tamper proof fixings also available.

Lighting trunking is available in 50mm x 50mm with straights in various length configurations. This range utilises the standard distribution trunking components but with snap on lids available in pre-galvanised steel or white plastic. This allows flexibility on site when using both systems.

Metsec cable trunking systems are manufactured on sophisticated CNC equipment with a high level of automation for fast moving items. The fully integrated production process ensures Metsec is able to offer a high level of service.



Development and testing

Metsec trunking systems have been developed to meet the requirements of BS EN 50085-1 + A1 and BS EN 50085-2-1 + A1 Cable trunking systems and cable ducting systems for electrical installations.

Comprehensive stock, rapid delivery

Metsec manufactures to lean principles on a Kanban system for stock control. This ensures a high level of delivery performance is achieved to meet the demanding service requirements needed to meet the needs of end users.

Comprehensive stocks are available at all times and Metsec has the ability to turn around non-standard applications quickly due to the sophisticated manufacturing processes employed. The virtual factory software used in the manufacturing process provides a continuous monitoring tool for stocks, work in progress and replenishment times.

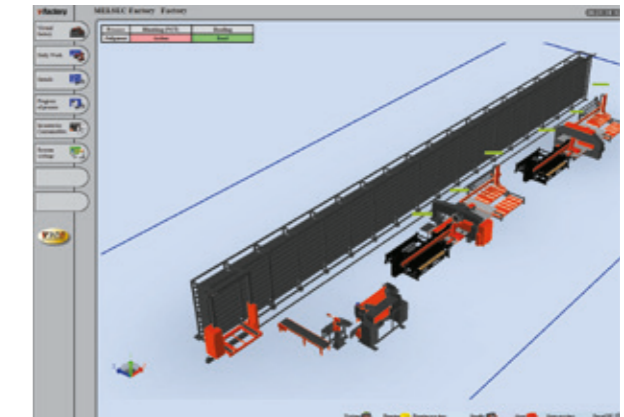

CABLE TRUNKING SYSTEMS

System Configuration and Support

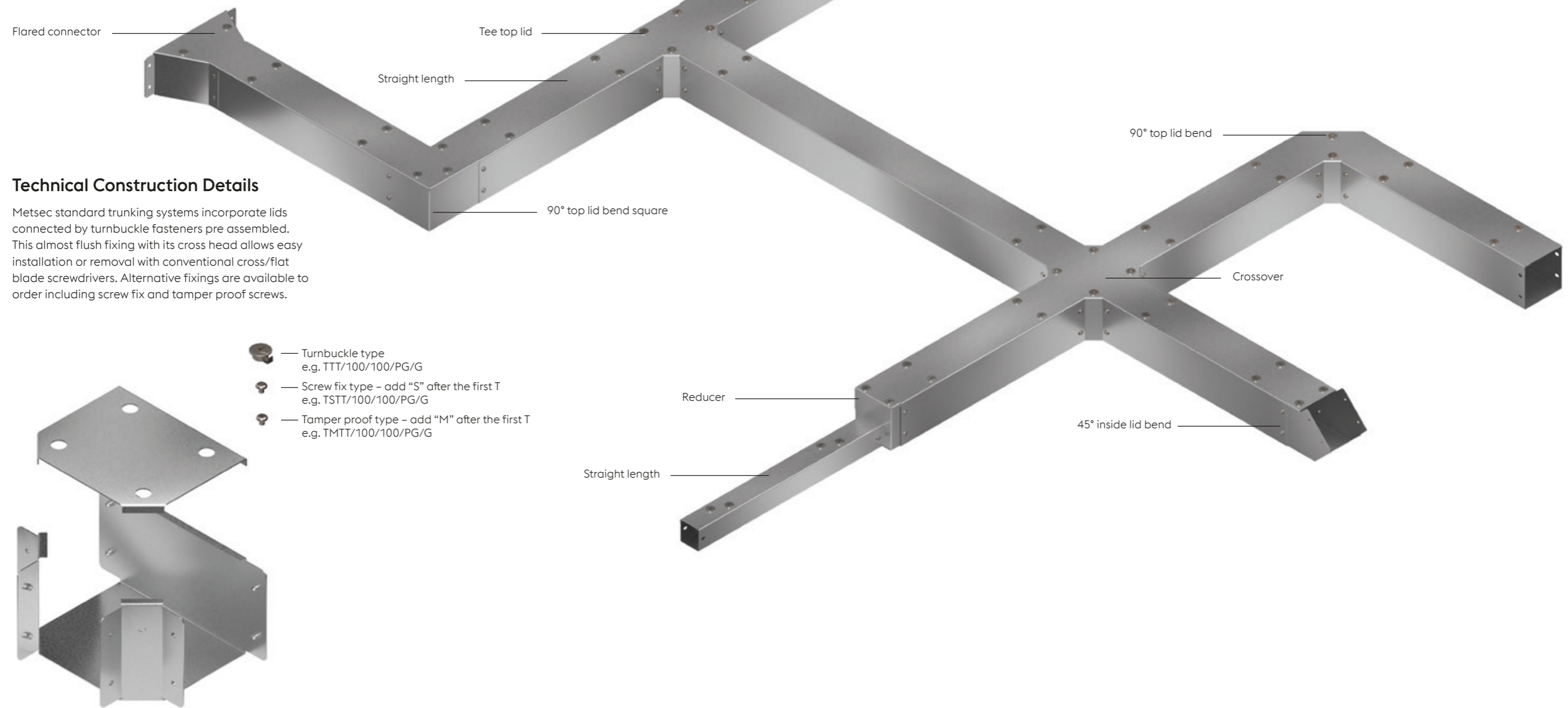

Metsec cable trunking systems are designed as a complete system with a range of easy fit accessories. Integral connectors are included for all fittings as well as fixing bolts. These connectors include pre tapped holes avoiding the need for nuts and washers. Trunking straight lengths come complete with coupler and fixing screws.

Metsec lighting trunking utilises the same accessories as the standard trunking range, but straight bodies are available in numerous length configurations. Clip on lids are available for this range in both metal galvanised or white plastic.



Technical Construction Details

Metsec standard trunking systems incorporate lids connected by turnbuckle fasteners pre assembled. This almost flush fixing with its cross head allows easy installation or removal with conventional cross/flat blade screwdrivers. Alternative fixings are available to order including screw fix and tamper proof screws.

-  Turnbuckle type
e.g. TTT/100/100/PG/G
-  Screw fix type - add "S" after the first T
e.g. TSTT/100/100/PG/G
-  Tamper proof type - add "M" after the first T
e.g. TMTT/100/100/PG/G

Materials and Finishes

Materials and finishes available are mild steel pre-galvanised as standard and powder coated to order.

Mild steel pre-galvanised: manufactured from steel complying with BS EN 10346.

Powder coating is available as an additional surface finish. Please provide the required RAL or BS colour and the level of Matt/Semi or Gloss when ordering.

IP4X

Metsec provides product solutions to IP4X enabling us to make a positive contribution to the supply chain by easing lead times, reducing material costs and supporting a sustainable, safe and compliant Cable Management solution.

Currently, British Standards for metal cable containment systems demand that all single insulated, non-sheathed cables be contained in an enclosure that meets either IP4X or IPXXD rating.

IP4X specifies that protection against a 1.0mm probe is required and that there is

no requirement for the protection from the ingress of water. Consequently, IP4X may not be watertight but it protects the cabling from ingress of debris or wire – or generally foreign objects that could all compromise the safety of the cabling within – tested with a 1mm diameter probe that will not penetrate any trunking.

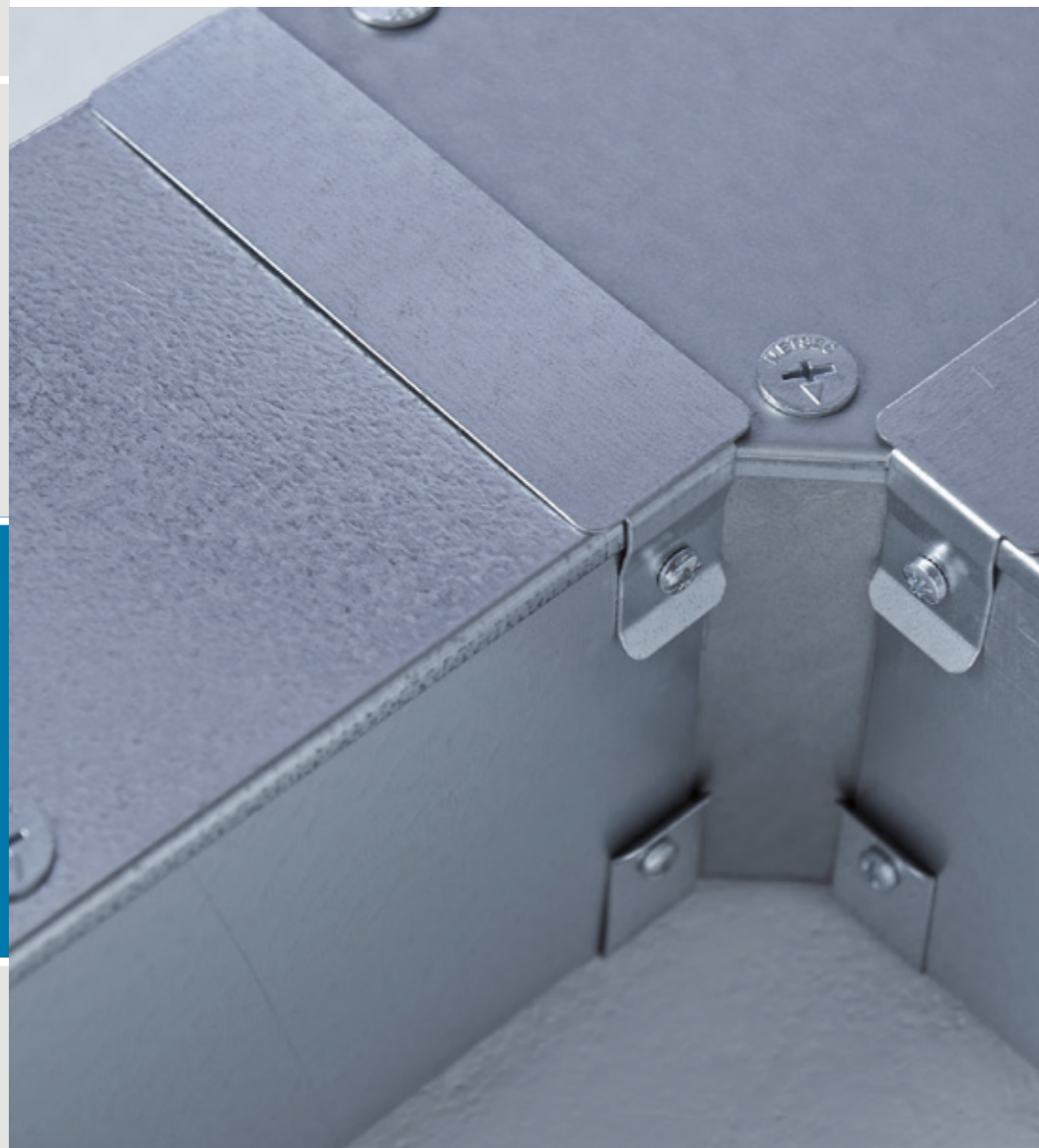

By meeting the IP4X standard, specifiers can give installers and those servicing the installation the confidence that the system meets the requirements of the Wiring Regulations in the most robust way.

Our IP4X rated trunking systems utilise off the shelf clips, without the need for bespoke systems. IP4X kits are available for the vast majority of the Metsec cable trunking range.

Features

- » Off the shelf clips
- » Can be delivered at a standard lead time

Benefits

- » Proven to meet recognised industry standards through rigorous BSI Kitemark™ testing, demonstrating safety, reliability and quality
- » Greater level of ingress protection than IPXXD.
- » Conforms to BS7671 and BS EN 60529 + A2 for IP4X or IPXXD rated enclosures

STANDARDS

Metsec cable trunking systems generally conform to BS EN 50085-1 + A1 Cable trunking systems and cable ducting systems for electrical installations - Part 1: General requirements, and BS EN 50085-2-1 + A1 Cable trunking systems and cable ducting systems for electrical installations - Part 2-1: Cable trunking systems and cable ducting systems intended for mounting on walls and ceilings.

This European Standard specifies requirements and tests for cable trunking systems and cable ducting systems intended for the accommodation, and where necessary, for the electrically protective separation, of insulated conductors, cables and possibly other electrical equipment in electrical and/or communication systems installations. The maximum voltage of these installations is 1000V a.c. and 1500V d.c.

This standard does not apply to conduit systems, cable tray systems, cable ladder systems, power track systems or equipment covered by other standards.

3 Definitions

For the purpose of this European Standard the following definitions apply.

- 3.3 System component**
Part of the system which includes:
a) trunking length
b) trunking fitting
c) fixing device
d) apparatus mounting device
e) system accessory
- NB: a system does not necessarily include all system components a) to e). Different combinations of system components may be used.
- 3.4 Trunking length**
Main component of a cable trunking system comprising a base with one or more access covers which may be opened or removed.
- 3.6 Fitting**
System component to connect, change direction or terminate trunking lengths.

- 3.7 Fixing device**
System component to secure other system components to the wall, ceiling, floor or other structure.
- 3.8 Apparatus mounting device**
System component to accommodate electrical apparatus, (switches, socket outlets, circuit breakers, telephone outlets, etc.) which can be an integral part of electrical apparatus.
- 3.9 System accessory**
System component which provides a supplementary function.
- 3.10 Metallic system component**
System component which consists of metal only.
- 3.12 Composite system component**
System component comprising both metallic and non-metallic materials.

4 General requirements

Metsec cable trunking systems have been designed and constructed so that, where required, they provide reliable mechanical protection to the insulated conductors, cables and possibly other electrical equipment. Where required the system provides adequate electrical protection.

The system components meet the classifications as detailed/highlighted in Section 6.

6 Classifications

- 6.2 According to resistance to impact for installation and application**
6.2.4 Metsec cable trunking systems offer impact resistance of 2 J
- 6.3 According to temperatures as given in Tables 1, 2 and 3**

Table 1 – Minimum temperature

Minimum transport and storage temperature °C
-45
-25
-15
-5

Table 2 – Minimum temperature

Minimum installation and application temperature °C
-25
-15
-5
+5
+15

Table 3 – Maximum temperature

Maximum application temperature °C
+60
+90
+105
+120

- 6.4 According to resistance to flame propagation**
6.4.2 Metsec cable trunking systems are non flame propagating.
- 6.5 According to electrical continuity characteristic**
6.5.1 Metsec cable trunking systems have electrical continuity characteristic.
- 6.6 According to electrical insulating characteristic**
6.6.1 Metsec cable trunking is without electrical insulating characteristic.
- 6.7 to degrees of protection provided by enclosure according to BS EN 60529 + A2**
6.7.1 Metsec cable trunking is IP30.
- 6.9 According to system access cover retention**
6.9.2 Metsec cable trunking access cover can only be opened with a tool.
- 6.10 According to electrically protective separation**
6.10.1 Metsec cable trunking system without internal protective partition.
6.101 According to intended installation positions.
6.101.3.1 Surface mounted on wall.
6.101.3.2 Surface mounted on ceiling.
6.103 According to type.
6.103.2 Type 2 cable trunking system – distribution.

7 Marking and Documentation

7.1 Each system component is marked by label. Labels used fully comply with the rubbing test. Boxed items are labelled on the packaging.

8 Dimensions

There are no dimensions requirements.

9 Construction

- 9.1 Sharp edges**
Surfaces of system components which are likely to come into contact with cables during installation are inspected to ensure they shall not cause damage to the cables when installed correctly.
- 9.4 Mechanical connections**
Screwed connections have been designed to withstand the mechanical stresses occurring during installation and normal use and will not cause damage to cables when correctly inserted. Screwed connections are generally isometric threads fully compliant with tests in accordance with 9.4.1 of the standard. Screws intended to be tightened by means of a screwdriver should be to a torque of 2Nm per Table 4 – Torque values for the test of screwed connections.
Mechanical connections intended for re-use other than screwed connections have been tested in accordance with 9.4.2, i.e. fitted and removed 10 times. After the test, there was no damage to impair the further use of the mechanical connection, i.e. turnbuckle connectors.

- 9.6 Equipotential bonding**
9.6.1 Metsec cable trunking systems should not be used for equipotential bonding.
- 9.7 Access to live parts**
9.7.1 Metsec cable trunking systems are designed that when they are installed correctly as in normal use, live parts are not accessible.
9.7.4 knockouts meet the requirements of EN 61032
- 9.101 Assembling**
Metsec system components fit correctly generally using integral couplers with plunged and tapped holes.

10 Mechanical Properties

Metsec cable trunking systems have been tested to verify the classifications stated particularly relating to mechanical strength, impact resistance, system access cover retention, etc.

15 Electromagnetic Compatibility

Metsec cable trunking systems are in normal use, passive in respect of electromagnetic influences (emission and immunity).

NB: When products covered by this standard are installed as part of a wiring installation, the installation may emit or may be influenced by electromagnetic signals. The degree of influence will depend on the nature of the installation within its operating environment and the apparatus connected by the wiring.

STANDARD DISTRIBUTION TRUNKING

Straight Lengths

3m length with lid and coupler

Fixing Options: Turnbuckle type e.g. TSL/100/100/PG3
 Screw fix type – add “S” after the first T e.g. TSSL/100/100/PG3
 Tamper proof type – add “M” after the first T e.g. TMSL/100/100/PG3



Width mm	50mm Deep	75mm Deep	100mm Deep	150mm Deep	225mm Deep	300mm Deep
50	TSL/050/050/PG3	N/A	N/A	N/A	N/A	N/A
75	TSL/075/050/PG3	TSL/075/075/PG3	N/A	N/A	N/A	N/A
100	TSL/100/050/PG3	TSL/100/075/PG3	TSL/100/100/PG3	N/A	N/A	N/A
150	TSL/150/050/PG3	TSL/150/075/PG3	TSL/150/100/PG3	TSL/150/150/PG3	N/A	N/A
225	TSL/225/050/PG3	TSL/225/075/PG3	TSL/225/100/PG3	TSL/225/150/PG3	TSL/225/225/PG3	N/A
300	TSL/300/050/PG3	TSL/300/075/PG3	TSL/300/100/PG3	TSL/300/150/PG3	TSL/300/225/PG3	TSL/300/300/PG3

Bends

90° bend with top lid and gusset

Fixing Options: Turnbuckle type e.g. TTB/100/100/PG/G90
 Screw fix type – add “S” after the first T e.g. TSTB/100/100/PG/G90
 Tamper proof type – add “M” after the first T e.g. TMTB/100/100/PG/G90

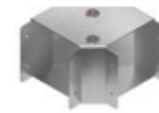

Width mm	50mm Deep	75mm Deep	100mm Deep	150mm Deep	225mm Deep	300mm Deep
50	TTB/050/050/PG/G90	N/A	N/A	N/A	N/A	N/A
75	TTB/075/050/PG/G90	TTB/075/075/PG/G90	N/A	N/A	N/A	N/A
100	TTB/100/050/PG/G90	TTB/100/075/PG/G90	TTB/100/100/PG/G90	N/A	N/A	N/A
150	TTB/150/050/PG/G90	TTB/150/075/PG/G90	TTB/150/100/PG/G90	TTB/150/150/PG/G90	N/A	N/A
225	TTB/225/050/PG/G90	TTB/225/075/PG/G90	TTB/225/100/PG/G90	TTB/225/150/PG/G90	TTB/225/225/PG/G90	N/A
300	TTB/300/050/PG/G90	TTB/300/075/PG/G90	TTB/300/100/PG/G90	TTB/300/150/PG/G90	TTB/300/225/PG/G90	TTB/300/300/PG/G90

90° bend with top lid and square

Fixing Options: Turnbuckle type e.g. TTB/100/100/PG/S90
 Screw fix type – add “S” after the first T e.g. TSTB/100/100/PG/S90
 Tamper proof type – add “M” after the first T e.g. TMTB/100/100/PG/S90



Width mm	50mm Deep	75mm Deep	100mm Deep	150mm Deep	225mm Deep	300mm Deep
50	TTB/050/050/PG/S90	N/A	N/A	N/A	N/A	N/A
75	TTB/075/050/PG/S90	TTB/075/075/PG/S90	N/A	N/A	N/A	N/A
100	TTB/100/050/PG/S90	TTB/100/075/PG/S90	TTB/100/100/PG/S90	N/A	N/A	N/A
150	TTB/150/050/PG/S90	TTB/150/075/PG/S90	TTB/150/100/PG/S90	TTB/150/150/PG/S90	N/A	N/A
225	TTB/225/050/PG/S90	TTB/225/075/PG/S90	TTB/225/100/PG/S90	TTB/225/150/PG/S90	TTB/225/225/PG/S90	N/A
300	TTB/300/050/PG/S90	TTB/300/075/PG/S90	TTB/300/100/PG/S90	TTB/300/150/PG/S90	TTB/300/225/PG/S90	TTB/300/300/PG/S90

90° bend with inside lid and gusset

Fixing Options: Turnbuckle type e.g. TIB/100/100/PG/S90
 Screw fix type – add “S” after the first T e.g. TSIB/100/100/PG/S90
 Tamper proof type – add “M” after the first T e.g. TMIB/100/100/PG/S90



Width mm	50mm Deep	75mm Deep	100mm Deep	150mm Deep	225mm Deep	300mm Deep
50	TIB/050/050/PG/S90	N/A	N/A	N/A	N/A	N/A
75	TIB/075/050/PG/S90	TIB/075/075/PG/S90	N/A	N/A	N/A	N/A
100	TIB/100/050/PG/S90	TIB/100/075/PG/S90	TIB/100/100/PG/S90	N/A	N/A	N/A
150	TIB/150/050/PG/S90	TIB/150/075/PG/S90	TIB/150/100/PG/S90	TIB/150/150/PG/S90	N/A	N/A
225	TIB/225/050/PG/S90	TIB/225/075/PG/S90	TIB/225/100/PG/S90	TIB/225/150/PG/S90	TIB/225/225/PG/S90	N/A
300	TIB/300/050/PG/S90	TIB/300/075/PG/S90	TIB/300/100/PG/S90	TIB/300/150/PG/S90	TIB/300/225/PG/S90	TIB/300/300/PG/S90

90° bend with inside lid and square

Fixing Options: Turnbuckle type e.g. TIB/100/100/PG/S90
 Screw fix type – add “S” after the first T e.g. TSIB/100/100/PG/S90
 Tamper proof type – add “M” after the first T e.g. TMIB/100/100/PG/S90

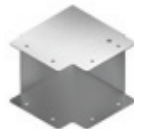

Width mm	50mm Deep	75mm Deep	100mm Deep	150mm Deep	225mm Deep	300mm Deep
50	TIB/050/050/PG/S90	N/A	N/A	N/A	N/A	N/A
75	TIB/075/050/PG/S90	TIB/075/075/PG/S90	N/A	N/A	N/A	N/A
100	TIB/100/050/PG/S90	TIB/100/075/PG/S90	TIB/100/100/PG/S90	N/A	N/A	N/A
150	TIB/150/050/PG/S90	TIB/150/075/PG/S90	TIB/150/100/PG/S90	TIB/150/150/PG/S90	N/A	N/A
225	TIB/225/050/PG/S90	TIB/225/075/PG/S90	TIB/225/100/PG/S90	TIB/225/150/PG/S90	TIB/225/225/PG/S90	N/A
300	TIB/300/050/PG/S90	TIB/300/075/PG/S90	TIB/300/100/PG/S90	TIB/300/150/PG/S90	TIB/300/225/PG/S90	TIB/300/300/PG/S90

90° bend with outside lid and gusset

Fixing Options: Turnbuckle type e.g. TOB/100/100/PG/G90
 Screw fix type – add “S” after the first T e.g. TSOB/100/100/PG/G90
 Tamper proof type – add “M” after the first T e.g. TMOB/100/100/PG/G90



Width mm	50mm Deep	75mm Deep	100mm Deep	150mm Deep	225mm Deep	300mm Deep
50	TOB/050/050/PG/G90	N/A	N/A	N/A	N/A	N/A
75	TOB/075/050/PG/G90	TOB/075/075/PG/G90	N/A	N/A	N/A	N/A
100	TOB/100/050/PG/G90	TOB/100/075/PG/G90	TOB/100/100/PG/G90	N/A	N/A	N/A
150	TOB/150/050/PG/G90	TOB/150/075/PG/G90	TOB/150/100/PG/G90	TOB/150/150/PG/G90	N/A	N/A
225	TOB/225/050/PG/G90	TOB/225/075/PG/G90	TOB/225/100/PG/G90	TOB/225/150/PG/G90	TOB/225/225/PG/G90	N/A
300	TOB/300/050/PG/G90	TOB/300/075/PG/G90	TOB/300/100/PG/G90	TOB/300/150/PG/G90	TOB/300/225/PG/G90	TOB/300/300/PG/G90

90° bend with outside lid and square

Fixing Options: Turnbuckle type e.g. TOB/100/100/PG/S90
 Screw fix type – add “S” after the first T e.g. TSOB/100/100/PG/S90
 Tamper proof type – add “M” after the first T e.g. TMOB/100/100/PG/S90



Width mm	50mm Deep	75mm Deep	100mm Deep	150mm Deep	225mm Deep	300mm Deep
50	TOB/050/050/PG/S90	N/A	N/A	N/A	N/A	N/A
75	TOB/075/050/PG/S90	TOB/075/075/PG/S90	N/A	N/A	N/A	N/A
100	TOB/100/050/PG/S90	TOB/100/075/PG/S90	TOB/100/100/PG/S90	N/A	N/A	N/A
150	TOB/150/050/PG/S90	TOB/150/075/PG/S90	TOB/150/100/PG/S90	TOB/150/150/PG/S90	N/A	N/A
225	TOB/225/050/PG/S90	TOB/225/075/PG/S90	TOB/225/100/PG/S90	TOB/225/150/PG/S90	TOB/225/225/PG/S90	N/A
300	TOB/300/050/PG/S90	TOB/300/075/PG/S90	TOB/300/100/PG/S90	TOB/300/150/PG/S90	TOB/300/225/PG/S90	TOB/300/300/PG/S90

45° bend with top lid and gusset

Fixing Options: Turnbuckle type e.g. TTB/100/100/PG/G45
 Screw fix type – add “S” after the first T e.g. TSTB/100/100/PG/G45
 Tamper proof type – add “M” after the first T e.g. TMTB/100/100/PG/G45

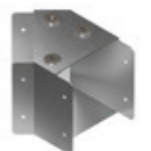

Width mm	50mm Deep	75mm Deep	100mm Deep	150mm Deep	225mm Deep	300mm Deep
50	TTB/050/050/PG/G45	N/A	N/A	N/A	N/A	N/A
75	TTB/075/050/PG/G45	TTB/075/075/PG/G45	N/A	N/A	N/A	N/A
100	TTB/100/050/PG/G45	TTB/100/075/PG/G45	TTB/100/100/PG/G45	N/A	N/A	N/A
150	TTB/150/050/PG/G45	TTB/150/075/PG/G45	TTB/150/100/PG/G45	TTB/150/150/PG/G45	N/A	N/A
225	TTB/225/050/PG/G45	TTB/225/075/PG/G45	TTB/225/100/PG/G45	TTB/225/150/PG/G45	TTB/225/225/PG/G45	N/A
300	TTB/300/050/PG/G45	TTB/300/075/PG/G45	TTB/300/100/PG/G45	TTB/300/150/PG/G45	TTB/300/225/PG/G45	TTB/300/300/PG/G45



45° bend with inside lid and gusset

Fixing Options: Turnbuckle type e.g. TIB/100/100/PG/G45
 Screw fix type – add “S” after the first T e.g. TSIB/100/100/PG/G45
 Tamper proof type – add “M” after the first T e.g. TMIB/100/100/PG/G45



Width mm	50mm Deep	75mm Deep	100mm Deep	150mm Deep	225mm Deep	300mm Deep
50	TIB/050/050/PG/G45	N/A	N/A	N/A	N/A	N/A
75	TIB/075/050/PG/G45	TIB/075/075/PG/G45	N/A	N/A	N/A	N/A
100	TIB/100/050/PG/G45	TIB/100/075/PG/G45	TIB/100/100/PG/G45	N/A	N/A	N/A
150	TIB/150/050/PG/G45	TIB/150/075/PG/G45	TIB/150/100/PG/G45	TIB/150/150/PG/G45	N/A	N/A
225	TIB/225/050/PG/G45	TIB/225/075/PG/G45	TIB/225/100/PG/G45	TIB/225/150/PG/G45	TIB/225/225/PG/G45	N/A
300	TIB/300/050/PG/G45	TIB/300/075/PG/G45	TIB/300/100/PG/G45	TIB/300/150/PG/G45	TIB/300/225/PG/G45	TIB/300/300/PG/G45

45° bend with outside lid and gusset

Fixing Options: Turnbuckle type e.g. TOB/100/100/PG/G45
 Screw fix type – add “S” after the first T e.g. TSOB/100/100/PG/G45
 Tamper proof type – add “M” after the first T e.g. TMOB/100/100/PG/G45

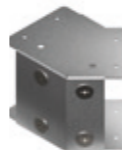

Width mm	50mm Deep	75mm Deep	100mm Deep	150mm Deep	225mm Deep	300mm Deep
50	TOB/050/050/PG/G45	N/A	N/A	N/A	N/A	N/A
75	TOB/075/050/PG/G45	TOB/075/075/PG/G45	N/A	N/A	N/A	N/A
100	TOB/100/050/PG/G45	TOB/100/075/PG/G45	TOB/100/100/PG/G45	N/A	N/A	N/A
150	TOB/150/050/PG/G45	TOB/150/075/PG/G45	TOB/150/100/PG/G45	TOB/150/150/PG/G45	N/A	N/A
225	TOB/225/050/PG/G45	TOB/225/075/PG/G45	TOB/225/100/PG/G45	TOB/225/150/PG/G45	TOB/225/225/PG/G45	N/A
300	TOB/300/050/PG/G45	TOB/300/075/PG/G45	TOB/300/100/PG/G45	TOB/300/150/PG/G45	TOB/300/225/PG/G45	TOB/300/300/PG/G45

Tees

Tee with top lid and gusset

Fixing Options: Turnbuckle type e.g. TTT/100/100/PG/G
 Screw fix type – add “S” after the first T e.g. TSTT/100/100/PG/G
 Tamper proof type – add “M” after the first T e.g. TMTT/100/100/PG/G

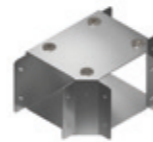

Width mm	50mm Deep	75mm Deep	100mm Deep	150mm Deep	225mm Deep	300mm Deep
50	TTT/050/050/PG/G	N/A	N/A	N/A	N/A	N/A
75	TTT/075/050/PG/G	TTT/075/075/PG/G	N/A	N/A	N/A	N/A
100	TTT/100/050/PG/G	TTT/100/075/PG/G	TTT/100/100/PG/G	N/A	N/A	N/A
150	TTT/150/050/PG/G	TTT/150/075/PG/G	TTT/150/100/PG/G	TTT/150/150/PG/G	N/A	N/A
225	TTT/225/050/PG/G	TTT/225/075/PG/G	TTT/225/100/PG/G	TTT/225/150/PG/G	TTT/225/225/PG/G	N/A
300	TTT/300/050/PG/G	TTT/300/075/PG/G	TTT/300/100/PG/G	TTT/300/150/PG/G	TTT/300/225/PG/G	TTT/300/300/PG/G

Tee with top lid and square

Fixing Options: Turnbuckle type e.g. TTT/100/100/PG/S
 Screw fix type – add “S” after the first T e.g. TSTT/100/100/PG/S
 Tamper proof type – add “M” after the first T e.g. TMTT/100/100/PG/S

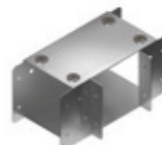

Width mm	50mm Deep	75mm Deep	100mm Deep	150mm Deep	225mm Deep	300mm Deep
50	TTT/050/050/PG/S	N/A	N/A	N/A	N/A	N/A
75	TTT/075/050/PG/S	TTT/075/075/PG/S	N/A	N/A	N/A	N/A
100	TTT/100/050/PG/S	TTT/100/075/PG/S	TTT/100/100/PG/S	N/A	N/A	N/A
150	TTT/150/050/PG/S	TTT/150/075/PG/S	TTT/150/100/PG/S	TTT/150/150/PG/S	N/A	N/A
225	TTT/225/050/PG/S	TTT/225/075/PG/S	TTT/225/100/PG/S	TTT/225/150/PG/S	TTT/225/225/PG/S	N/A
300	TTT/300/050/PG/S	TTT/300/075/PG/S	TTT/300/100/PG/S	TTT/300/150/PG/S	TTT/300/225/PG/S	TTT/300/300/PG/S

Tee with inside lid and gusset

Fixing Options: Turnbuckle type e.g. TIT/100/100/PG/G
 Screw fix type – add “S” after the first T e.g. TSIT/100/100/PG/G
 Tamper proof type – add “M” after the first T e.g. TMIT/100/100/PG/G

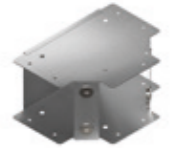

Width mm	50mm Deep	75mm Deep	100mm Deep	150mm Deep	225mm Deep	300mm Deep
50	TIT/050/050/PG/G	N/A	N/A	N/A	N/A	N/A
75	TIT/075/050/PG/G	TIT/075/075/PG/G	N/A	N/A	N/A	N/A
100	TIT/100/050/PG/G	TIT/100/075/PG/G	TIT/100/100/PG/G	N/A	N/A	N/A
150	TIT/150/050/PG/G	TIT/150/075/PG/G	TIT/150/100/PG/G	TIT/150/150/PG/G	N/A	N/A
225	TIT/225/050/PG/G	TIT/225/075/PG/G	TIT/225/100/PG/G	TIT/225/150/PG/G	TIT/225/225/PG/G	N/A
300	TIT/300/050/PG/G	TIT/300/075/PG/G	TIT/300/100/PG/G	TIT/300/150/PG/G	TIT/300/225/PG/G	TIT/300/300/PG/G

Tee with outside lid and gusset

Fixing Options: Turnbuckle type e.g. TOT/100/100/PG/G
 Screw fix type – add “S” after the first T e.g. TSOT/100/100/PG/G
 Tamper proof type – add “M” after the first T e.g. TMOT/100/100/PG/G

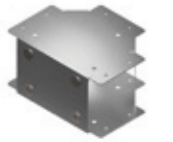

Width mm	50mm Deep	75mm Deep	100mm Deep	150mm Deep	225mm Deep	300mm Deep
50	TOT/050/050/PG/G	N/A	N/A	N/A	N/A	N/A
75	TOT/075/050/PG/G	TOT/075/075/PG/G	N/A	N/A	N/A	N/A
100	TOT/100/050/PG/G	TOT/100/075/PG/G	TOT/100/100/PG/G	N/A	N/A	N/A
150	TOT/150/050/PG/G	TOT/150/075/PG/G	TOT/150/100/PG/G	TOT/150/150/PG/G	N/A	N/A
225	TOT/225/050/PG/G	TOT/225/075/PG/G	TOT/225/100/PG/G	TOT/225/150/PG/G	TOT/225/225/PG/G	N/A
300	TOT/300/050/PG/G	TOT/300/075/PG/G	TOT/300/100/PG/G	TOT/300/150/PG/G	TOT/300/225/PG/G	TOT/300/300/PG/G

Crossovers & Reducers

Crossovers

Fixing Options: Turnbuckle type e.g. TCO/100/100/PG/G
 Screw fix type – add “S” after the first T e.g. TSCO/100/100/PG/G
 Tamper proof type – add “M” after the first T e.g. TMCO/100/100/PG/G

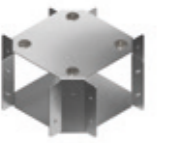

Width mm	50mm Deep	75mm Deep	100mm Deep	150mm Deep	225mm Deep	300mm Deep
50	TCO/050/050/PG/G	N/A	N/A	N/A	N/A	N/A
75	TCO/075/050/PG/G	TCO/075/075/PG/G	N/A	N/A	N/A	N/A
100	TCO/100/050/PG/G	TCO/100/075/PG/G	TCO/100/100/PG/G	N/A	N/A	N/A
150	TCO/150/050/PG/G	TCO/150/075/PG/G	TCO/150/100/PG/G	TCO/150/150/PG/G	N/A	N/A
225	TCO/225/050/PG/G	TCO/225/075/PG/G	TCO/225/100/PG/G	TCO/225/150/PG/G	TCO/225/225/PG/G	N/A
300	TCO/300/050/PG/G	TCO/300/075/PG/G	TCO/300/100/PG/G	TCO/300/150/PG/G	TCO/300/225/PG/G	TCO/300/300/PG/G

Reducers

Fixing Options: Turnbuckle type e.g. TTR/100/100/TO/050/050/PG
 Screw fix type – add “S” after the first T e.g. TSTR/100/100/TO/050/050/PG
 Tamper proof type – add “M” after the first T e.g. TMTR/100/100/TO/050/050/PG



Width 1 mm	Width 2 mm			
	50 x 50	75 x 75	100 x 100	150 x 150
75 x 75	TTR/075/075/TO/050/050/PG	N/A	N/A	N/A
100 x 100	TTR/100/100/TO/050/050/PG	TTR/100/100/TO/075/075/PG	N/A	N/A
150 x 150	TTR/150/150/TO/050/050/PG	TTR/150/150/TO/075/075/PG	TTR/150/150/TO/100/100/PG	N/A
225 x 225	TTR/225/225/TO/050/050/PG	TTR/225/225/TO/075/075/PG	TTR/225/225/TO/100/100/PG	TTR/225/225/TO/150/150/PG
300 x 300	TTR/300/300/TO/050/050/PG	TTR/300/300/TO/075/075/PG	TTR/300/300/TO/100/100/PG	TTR/300/300/TO/150/150/PG



Accessories & Lids

Flared connector

Fixing Options: Turnbuckle type e.g. TFC/100/100/PG
Screw fix type – add “S” after the first T e.g. TSFC/100/100/PG
Tamper proof type – add “M” after the first T e.g. TMFC/100/100/PG

Width mm	50mm Deep	75mm Deep	100mm Deep	150mm Deep	225mm Deep	300mm Deep
50	TFC/050/050/PG	N/A	N/A	N/A	N/A	N/A
75	TFC/075/050/PG	TFC/075/075/PG	N/A	N/A	N/A	N/A
100	TFC/100/050/PG	TFC/100/075/PG	TFC/100/100/PG	N/A	N/A	N/A
150	TFC/150/050/PG	TFC/150/075/PG	TFC/150/100/PG	TFC/150/150/PG	N/A	N/A
225	TFC/225/050/PG	TFC/225/075/PG	TFC/225/100/PG	TFC/225/150/PG	TFC/225/225/PG	N/A
300	TFC/300/050/PG	TFC/300/075/PG	TFC/300/100/PG	TFC/300/150/PG	TFC/300/225/PG	TFC/300/300/PG/PG



Fitting to fitting connector

Fixing Options: Turnbuckle type e.g. TAC/100/100/PG
Screw fix type – add “S” after the first T e.g. TSAC/100/100/PG
Tamper proof type – add “M” after the first T e.g. TMAC/100/100/PGPG

Width mm	50mm Deep	75mm Deep	100mm Deep	150mm Deep	225mm Deep	300mm Deep
50	TAC/050/050/PG	N/A	N/A	N/A	N/A	N/A
75	TAC/075/050/PG	TAC/075/075/PG	N/A	N/A	N/A	N/A
100	TAC/100/050/PG	TAC/100/075/PG	TAC/100/100/PG	N/A	N/A	N/A
150	TAC/150/050/PG	TAC/150/075/PG	TAC/150/100/PG	TAC/150/150/PG	N/A	N/A
225	TAC/225/050/PG	TAC/225/075/PG	TAC/225/100/PG	TAC/225/150/PG	TAC/225/225/PG	N/A
300	TAC/300/050/PG	TAC/300/075/PG	TAC/300/100/PG	TAC/300/150/PG	TAC/300/225/PG	TAC/300/300/PG



Stop end

Width mm	50mm Deep	75mm Deep	100mm Deep	150mm Deep	225mm Deep	300mm Deep
50	TSE4X/050/050/PG	N/A	N/A	N/A	N/A	N/A
75	TSE4X/075/050/PG	TSE4X/075/075/PG	N/A	N/A	N/A	N/A
100	TSE4X/100/050/PG	TSE4X/100/075/PG	TSE4X/100/100/PG	N/A	N/A	N/A
150	TSE4X/150/050/PG	TSE4X/150/075/PG	TSE4X/150/100/PG	TSE4X/150/150/PG	N/A	N/A
225	TSE4X/225/050/PG	TSE4X/225/075/PG	TSE4X/225/100/PG	TSE4X/225/150/PG	TSE4X/225/225/PG	N/A
300	TSE4X/300/050/PG	TSE4X/300/075/PG	TSE4X/300/100/PG	TSE4X/300/150/PG	TSE4X/300/225/PG	TSE4X/300/300/PG



Flange bracket

Width mm	50mm Deep	75mm Deep	100mm Deep	150mm Deep	225mm Deep	300mm Deep
50	TFL/050/050/PG	N/A	N/A	N/A	N/A	N/A
75	TFL/075/050/PG	TFL/075/075/PG	N/A	N/A	N/A	N/A
100	TFL/100/050/PG	TFL/100/075/PG	TFL/100/100/PG	N/A	N/A	N/A
150	TFL/150/050/PG	TFL/150/075/PG	TFL/150/100/PG	TFL/150/150/PG	N/A	N/A
225	TFL/225/050/PG	TFL/225/075/PG	TFL/225/100/PG	TFL/225/150/PG	TFL/225/225/PG	N/A
300	TFL/300/050/PG	TFL/300/075/PG	TFL/300/100/PG	TFL/300/150/PG	TFL/300/225/PG	TFL/300/300/PG



Trunking connector

Width mm	50mm Deep	75mm Deep	100mm Deep	150mm Deep	225mm Deep
50	TC/050/050/PG/PK10	N/A	N/A	N/A	N/A
75	TC/075/050/PG/PK10	TC/075/075/PG/PK10	N/A	N/A	N/A
100	TC/100/050/PG/PK10	TC/100/075/PG/PK10	TC/100/100/PG/PK10	N/A	N/A
150	TC/150/050/PG/PK5	TC/150/075/PG/PK5	TC/150/100/PG/PK5	TC/150/150/PG/PK5	N/A
225	TC/225/050/PG/PK5	TC/225/075/PG/PK5	TC/225/100/PG/PK5	TC/225/150/PG/PK5	TC/225/225/PG/PK5



Turnbuckle lid 3m long

Width mm	
50	TSC/050/PG/3
75	TSC/075/PG/3
100	TSC/100/PG/3
150	TSC/150/PG/3
225	TSC/225/PG/3
300	TSC/300/PG/3



Hanger bracket

Width mm	
50	THB/050/PG
75	THB/075/PG
100	THB/100/PG
150	THB/150/PG
225	THB/225/PG
300	N/A



Screw fix lid 3m long

Fasteners not included

Width mm	
50	TSSC/050/PG/3
75	TSSC/075/PG/3
100	TSSC/100/PG/3
150	TSSC/150/PG/3
225	TSSC/225/PG/3
300	TSSC/300/PG/3



Cable retainer

Width mm	Pack of 10
50	TCR/050/PG/PK10
75	TCR/075/PG/PK10
100	TCR/100/PG/PK10
150	TCR150/PG/PK10
225	TCR/225/PG/PK10
300	TCR/300/PG/PK10



Turnbuckles

Pack of 10

TB1/PK10



Earth link

Pack of 10

TES/PK10



Pin rack

Width mm	50mm Deep	75mm Deep	100mm Deep	150mm Deep	225mm Deep
50	TPR/050/050/PG	N/A	N/A	N/A	N/A
75	TPR/075/050/PG	TPR/075/075/PG	N/A	N/A	N/A
100	TPR/100/050/PG	TPR/100/075/PG	TPR/100/100/PG	N/A	N/A
150	TPR/150/050/PG	TPR/150/075/PG	TPR/150/100/PG	TPR/150/150/PG	N/A



M5 screw fixings

Pack of 4

M05x5CS/4



M5 tamper proof screw fixings

Pack of 4

M05x5SF/4



Divider 3m length

Fasteners not included

Depth mm	
50	TDI/050/PG/3
75	TDI/075/PG/3
100	TDI/100/PG/3
150	TDI/150/PG/3
225	TDI/225/PG/3
300	TDI/300/PG/3



COMPARTMENTALISED PRODUCTS

For 2 compartments:

Add 'C2' after part number, e.g. TTB/100/100/PG/G90/C2



2-compartment (C2)

For 3 compartments:

Add 'C3' after part number, e.g. TTB/100/100/PG/G90/C3.

Unless otherwise stated, all compartments will be of equal size.



3-compartment (C3)

Trunking with more than 3 compartments is available on request

Set outs for top lid tees

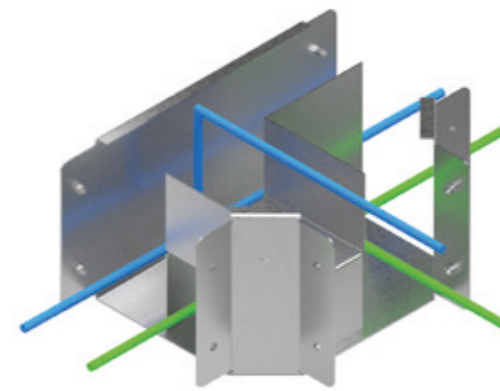

2-compartment

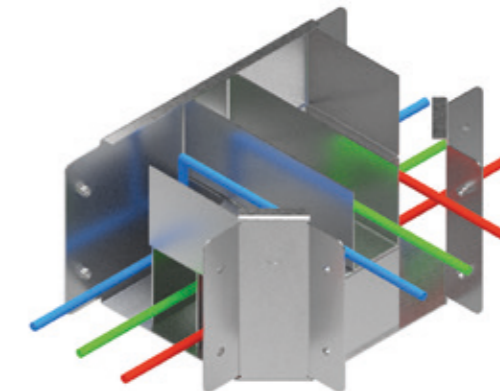

3-compartment

Set outs for crossovers

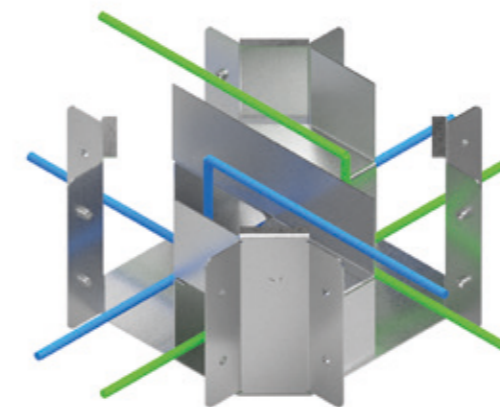

2-compartment

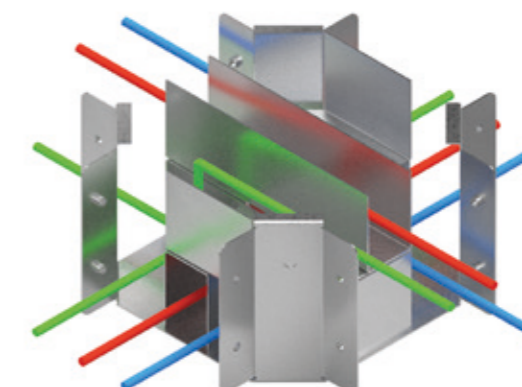

3-compartment

LIGHTING TRUNKING

Straight length

Trunking size mm	3m long	4m long	5m long	6m long
50x50	TLSL/050/050/PG3	TLSL/050/050/PG4	TLSL/050/050/PG5	TLSL/050/050/PG6

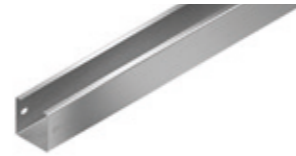

Galvanised snap-in lid

Trunking size mm	2m long
50x50	TLSL/050/C



45° bend top lid

Trunking size mm	
50x50	TLTB/050/050/PG/G45

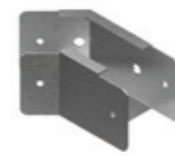

Plastic snap-in lid

Trunking size mm	2m long colour white
50x50	TLSL/050/CPVC



45° bend inside lid

Trunking size mm	
50x50	TLIB/050/050/PG/G45



90° bend top lid

Trunking size mm	
50x50	TLTB/050/050/PG/S90

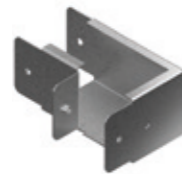

45° bend outside lid

Trunking size mm	
50x50	TLOB/050/050/PG/G45



90° bend inside lid

Trunking size mm	
50x50	TLIB/050/050/PG/S90

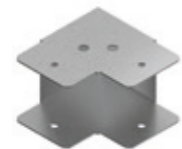

Tee top lid

Trunking size mm	
50x50	TLTT/050/050/PG/S



90° bend outside lid

Trunking size mm	
50x50	TLOB/050/050/PG/S90



Tee inside lid

Trunking size mm	
50x50	TLIT/050/050/PG/G



Connector

Trunking size mm	Pack of 10
50x50	TC/050/050/PG/PK10

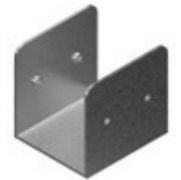

Tee outside lid

Trunking size mm	
50x50	TLOT/050/050/PG/G



Long connector

Trunking size mm	
50x50	TLC/050/050/PG



Crossover

Trunking size mm	
50x50	TLCO/050/050/PG/S



Stop end

Trunking size mm	
50x50	TSE4X/050/050/PG



Flange

Trunking size mm	
50x50	TFL/050/050/PG



Cable retainer

Trunking size mm	Pack of 10
50x50	TCR/050/PG/PK10



Stirrup hanger

Trunking size mm	
50x50	TLSH/10 11mm hole
50x50	TLSH/20 22mm hole



Suspension fitting

Trunking size mm	Pack of 10
50x50	TLA1/PK10

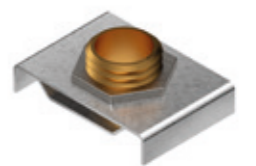



METAL FRAMING SYSTEMS

METAL FRAMING SYSTEMS

The Metsec metal framing system provides flexible and economical support solutions for mechanical and electrical services.

Four channel profiles are available as plain back or slotted back variants and each can be assembled into multiple configurations when additional load carrying capacity is needed. This is further complimented with a wide range of brackets and fasteners to achieve almost any framework assembly and configuration.

Metal framing systems can be found in almost all building sectors and in a wide range of applications.

Often used as a first fix component, Metsec systems are used to support cable trays, cable ladders and other items of capital equipment.

Cut-to-length service

Metsec offers a competitive cut-to-length service. By cutting in process, the integrity of the pre-galvanised coating is maintained on the cut end.

This service reduces the potential for waste when cut on site and provides substantial labour savings.

Pre-fabrication service

Considerable savings can be made on site by pre-fabrication modules and bracketry. Metsec offers this service see page 172.

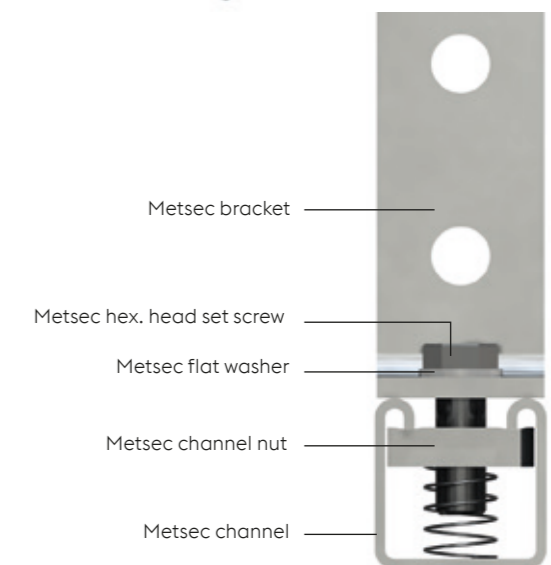
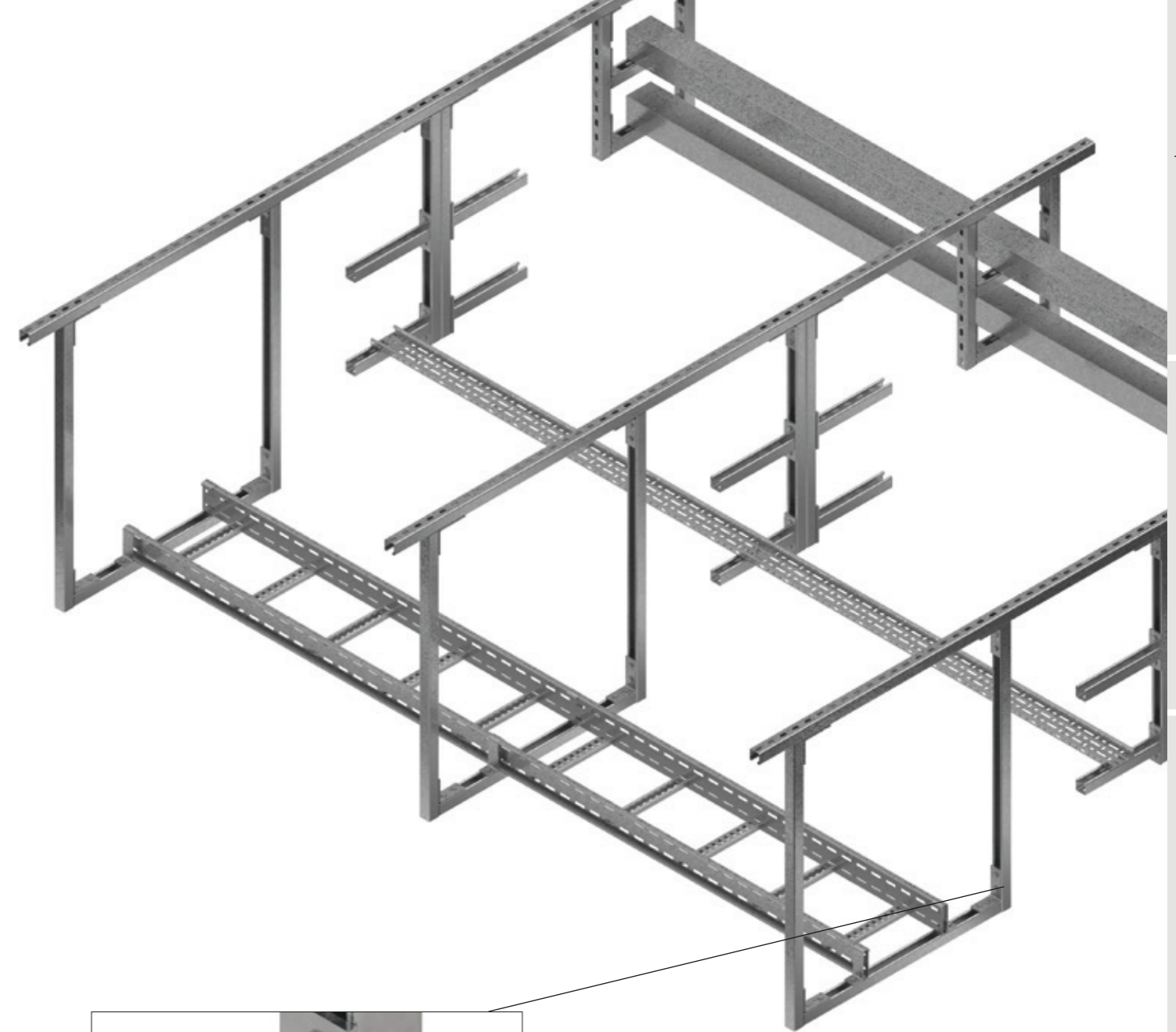

Always use the complete Metsec system

STANDARDS

The Metsec metal framing system comprises single and combination channels, assembly brackets, channel nuts and fasteners. The integration of these items in their use, forms the basis of the system and as such should be purchased as a complete system.

The Metsec metal framing system conforms to BS 6946, the British Standard Specification for Metal channel cable support systems for electrical installations.

Independent testing has been carried out to verify the load tables for the various channels and to determine pull out and slip performance of the channel nuts when used as a system.

It is this system integrity that needs to be maintained for all installations to meet site safety requirements.

The material used for the Metsec channels meets and surpasses the minimum yield strength of 250 N/mm² and brackets have a minimum yield strength of 170 N/mm².

Sectional dimensions

The standard requires channel sections to meet the dimensional requirements stated when measured not less than 150mm from the end. Twist will not be greater than 2.5° per metre and bow shall not exceed 5mm for channel 3m in length and 10mm for channel 6m in length, when measured at the centre of the length.

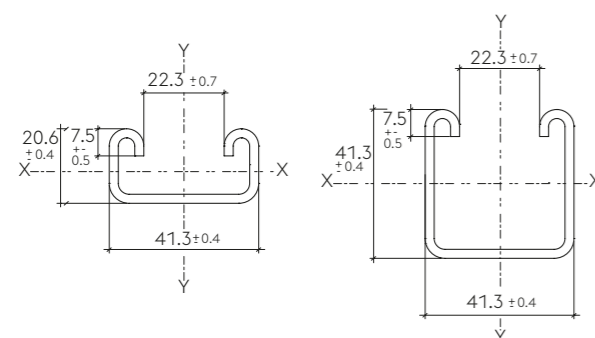

Safe working slip and pull-out loads

These have been determined by carrying out the tests in accordance with the method stated in section 8 of the standard. It should be noted that the channel nuts are a vital component within the system and the numerous imported products do not necessarily carry the same load and should never be mixed with Metsec systems.

Marking

Metsec channels are marked at regular intervals along their length in the production process. The standard requires the name of the manufacturer and BS 6946. Brackets and other components are marked by labelling the packaging.

Combination channels

Channels that are required in multiple configurations e.g. back to back channel, are supplied spot welded as standard. These channels should always be fully supported at each end under the bottom face and the load should never be hung from just the lips of the bottom channel. Spot welding should never be loaded in tension or the load applied as a bending moment.

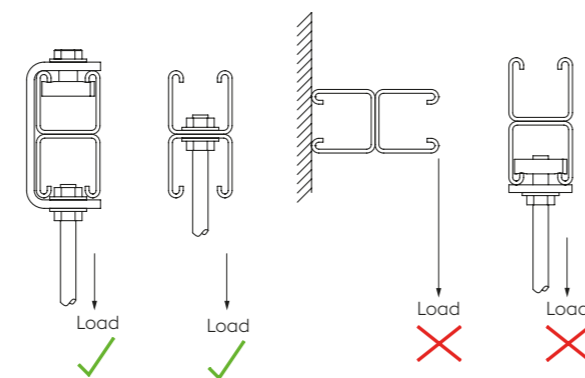

Material specification

- Channels: manufactured from steel complying with BS EN 10346 pre-galvanised, BS EN 10025-2 mild steel hot dip galvanised after manufacture to BS EN 1461 and BS EN 10088-1 and BS EN 10088-2 stainless steel grade 1.4404 (316L).
- Brackets: manufactured from steel complying with BS EN 10025-2 mild steel hot dip galvanised after manufacture to BS EN ISO 1461 and BS EN 10088-1 and BS EN 10088-2 stainless steel grade 1.4404 (316L).
- Fixings: bolts, hexagon nuts, screws and washers manufactured from steel complying with DIN938/8, DIN 933/8.8, BS4320 and zinc plated and CR3 passivated or hot dip galvanised after manufacture to BS EN ISO 1461. Stainless steel to BS EN 10088-1 and BS EN 10088-2 grade 1.4404 (316L) A4.

Dimensions and tolerances

In accordance with BS 6946 Metal channel cable support systems for electrical installations.

Channel notation

Metsec channel references are serialised for easy recognition and use, e.g.: channel series MS4125 comprises single channel or combinations of channel within the basic section profile thus:

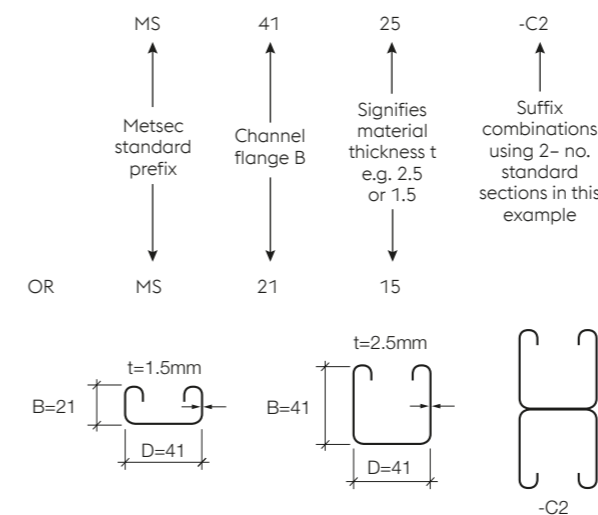

Load tables

Comprehensive load tables are provided for each channel series:
 MS4125 Series – Pages 134-135
 MS2125 Series – Pages 136-137
 MS4115 Series – Pages 138-139
 MS2115 Series – Pages 140-141
 Slotted Sections – Pages 142-145

Basis of design and formulation of load tables

- Safe loads calculated in accordance with BS EN 1993-1-3 Code of Practice for Design of Cold Formed Sections.
- Minimum Yield Stress (Ys) 280N/mm² (S280 GD + Z275 NA-C).
- Beams assumed simply supported and provided with adequate lateral restraint over the given span.
- Beam loads are applied through the shear centre of the section in the direction indicated in the tables.

- Alternative beam safe load tables are provided for a uniformly distributed load or load concentrated near the centre of the span, e.g.:

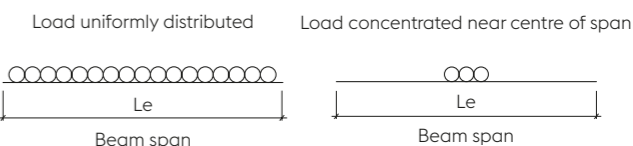

- Beam loads and corresponding deflections are calculated at a stress of 175N/mm² i.e.: using a global factor of safety of 1.6 to determine safe working loads from limit state analysis (ultimate stress + 1.6 = 175N/mm²). Beam safe loads tabulated with corresponding deflections may be used in the rare case where excessive deflection does not impair the strength or efficiency of the structure or its components or cause damage to the supported work.

Alternative safe loads are tabulated with deflections limited to span/200 or span/360 at the discretion of the designer and recommended where deflections are critical.

It is easily recognisable from the tables whether the design of the beam is governed by deflection or stress on a given span i.e.: the critical load is highlighted in colour.

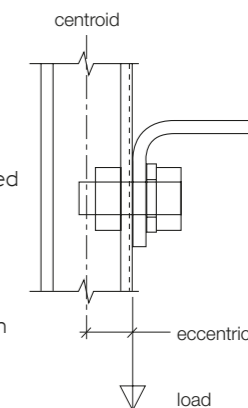

- Column effective lengths shall be determined by the designer in accordance with Table 9 of BS EN 1993-1-3.
- Beam loads are generally applied at the column face via the connection bracket. Therefore column safe load tables are provided allowing for this eccentricity of load from the centroid of the section.

Alternative combinations

For safe loads on alternative combinations not tabulated please refer to Metsec Cable Management Technical Department.

Stainless steel

The mechanical properties of stainless steel are significantly different from those for carbon steel and safe load tables must not be used for sections in this material. Please consult Metsec Cable Management Technical Department for advice.



MS2125

Finish: pre-galvanised = PG, post-galvanised = HDG

Section properties

Area cm ²	Wt kg/m	Ixx cm ⁴	Zxx (top) mm	Zxx (btm) mm	rxx cm	Iyy cm ⁴	Zyy cm ³	ryy mm
2.35	1.85	1.21	1	1.43	0.72	5.44	2.63	1.52

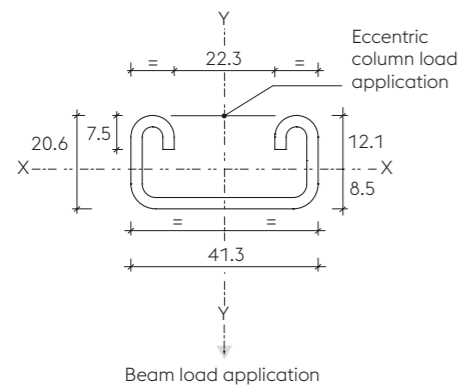

Safe load tables

Le (m)	Safe working loads in kg uniform		Def. limit span/200 (kg)	Def. limit span/360 (kg)	Safe working loads in kg concentrated		Def. limit span/200 (kg)	Def. limit span/360 (kg)	Safe column loads kg at centroid	Safe column loads kg at face
	(kg) Load	(mm) Def.			(kg) Load	(mm) Def.				
0.6	237	2.64	237	150	118	2.11	118	93	2978	894
0.7	203	3.59	198	110	101	2.87	101	69	2471	821
0.8	177	4.68	151	84	89	3.75	89	53	2019	747
0.9	158	5.94	120	66	79	4.75	75	42	1657	677
1	142	7.33	97	54	71	5.86	61	34	1375	613
1.1	129	8.87	80	44	65	7.09	50	28	1156	556
1.2	118	10.55	67	37	59	8.44	42	23	984	505
1.3	109	12.38	57	32	55	9.91	36	20		
1.4	101	14.36	49	27	51	11.49	31	17		
1.5	95	16.49	43	24	47	13.18	27	15		
1.6	89	18.76	38	21	44	15	24	13		
1.7	84	21.18	34	19	42	16.95	21	12		
1.8	79	23.74	30	17	39	19	19	10		
1.9	75	26.45	27	15	37	21.16	17	9		
2	71	29.31	24	13	35	23.45	15	8		
2.1	68	32.31	22	12	34	25.86	14	8		
2.2	65	35.46	20	11	32	28.38	13	7		
2.3	62	38.76	18	10	31	31.01	11	6		
2.4	59	42.2	17	9	30	33.77	11	6		
2.5	57	45.8	16	9	28	36.63	10	5		
2.6	55	49.53	14	8	27	39.63	9	5		
2.7	53	53.42	13	7	26	42.74	8	5		
2.8	51	57.45	12	7	25	45.95	8	4		
2.9	49	61.62	12	6	24	49.29	7	4		
3	47	65.95	11	6	24	52.76	7	4		

$\frac{\alpha \cdot L_e}{r_{xx}} > 180$

Loads not applicable to stainless steel, for stainless steel loads please consult the Technical Department for advice.

MS2125-C2

Combination comprising 2 no. MS2125

Finish: pre galvanised = PG, post galvanised = HDG

Section properties

Area cm ²	Wt kg/m	Ixx cm ⁴	Zxx (top) mm	Zxx (btm) mm	rxx cm	Iyy cm ⁴	Zyy cm ³	ryy mm
4.71	3.7	5.78	2.81	2.81	1.11	10.88	5.27	1.52

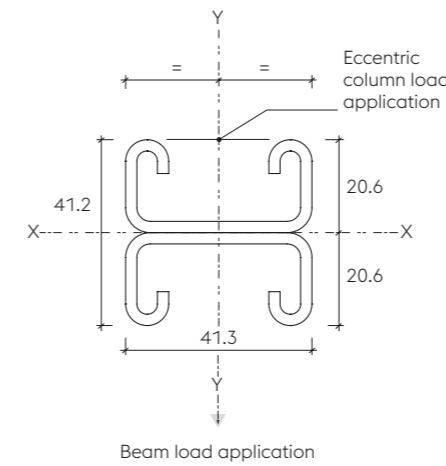

Safe load tables

Le (m)	Safe working loads in kg uniform		Def. limit span/200 (kg)	Def. limit span/360 (kg)	Safe working loads in kg concentrated		Def. limit span/200 (kg)	Def. limit span/360 (kg)	Safe column loads kg at centroid	Safe column loads kg at face
	(kg) Load	(mm) Def.			(kg) Load	(mm) Def.				
0.6	667	1.55	667	667	334	1.24	334	334	7582	1765
0.7	572	2.11	572	526	286	1.69	286	286	7214	1720
0.8	501	2.76	501	403	250	2.21	250	250	6733	1665
0.9	445	3.5	445	318	222	2.8	222	199	6140	1601
1	400	4.32	400	258	200	3.46	200	161	5484	1528
1.1	364	5.22	364	213	182	4.17	182	133	4835	1451
1.2	334	6.22	322	179	167	4.97	167	112	4243	1372
1.3	308	7.29	274	152	154	5.84	154	95	3726	1295
1.4	286	8.46	237	131	143	6.77	143	82	3284	1221
1.5	267	9.71	206	115	133	7.77	129	72	2908	1150
1.6	250	11.05	181	101	125	8.84	113	63	2589	1084
1.7	236	12.47	161	89	118	9.98	100	56	2317	1022
1.8	222	13.98	143	80	111	11.19	89	50	2084	964
1.9	211	15.58	129	71	105	12.47	80	45	1884	910
2	200	17.26	116	64	100	13.81	72	40		
2.1	191	19.03	105	58	95	15.23	66	37		
2.2	182	20.89	96	53	91	16.72	60	33		
2.3	174	22.83	88	49	87	18.27	55	30		
2.4	167	24.86	81	45	83	19.89	50	28		
2.5	160	26.98	74	41	80	21.58	46	26		
2.6	154	29.18	69	38	77	23.35	43	24		
2.7	148	31.46	64	35	74	25.18	40	22		
2.8	143	33.84	59	33	72	27.07	37	21		
2.9	138	36.3	55	31	69	29.04	34	19		
3	133	38.84	52	29	67	31.08	32	18		

$\frac{\alpha \cdot L_e}{r_{yy}} > 180$

Loads not applicable to stainless steel, for stainless steel loads please consult the Technical Department for advice.



MS2115

Finish: pre-galvanised = PG, post-galvanised = HDG

Section properties

Area cm ²	Wt kg/m	Ixx cm ⁴	Zxx (top) mm	Zxx (btm) mm	rxx cm	Iyy cm ⁴	Zyy cm ³	ryy mm
1.52	1.2	0.89	0.75	1.03	0.77	3.68	1.78	1.55

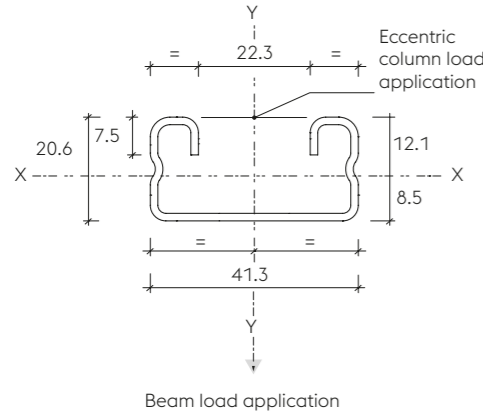

Safe load tables

Le (m)	Safe working loads in kg uniform		Def. limit span/200 (kg)	Def. limit span/360 (kg)	Safe working loads in kg concentrated		Def. limit span/200 (kg)	Def. limit span/360 (kg)	Safe column loads kg at centroid	Safe column loads kg at face
	(kg) Load	(mm) Def.			(kg) Load	(mm) Def.				
0.6	179	2.69	179	111	89	2.15	89	69	2051	663
0.7	153	3.66	147	81	77	2.93	77	51	1748	612
0.8	134	4.78	112	62	67	3.83	67	39	1453	558
1.5	119	6.05	89	49	60	4.84	55	31	1203	506
1	107	7.46	72	40	54	5.98	45	25	1004	459
1.1	97	9.03	59	33	49	7.23	37	21	847	416
1.2	89	10.75	50	28	45	8.6	31	17	722	378
1.3	82	12.62	42	24	41	10.09	27	15	622	344
1.4	77	14.63	37	20	38	11.7	23	13		
1.5	71	16.8	32	18	36	13.44	20	11		
1.6	67	19.11	28	16	33	15.28	18	10		
1.7	63	21.57	25	14	32	17.25	16	9		
1.8	60	24.19	22	12	30	19.35	14	8		
1.9	56	26.95	20	11	28	21.56	12	7		
2	54	29.86	18	10	27	23.88	11	6		
2.1	51	32.92	16	9	26	26.34	10	6		
2.2	49	26.13	15	8	24	28.9	9	5		
2.3	47	39.49	14	8	23	31.59	8	5		
2.4	45	43	12	7	22	34.39	8	4		
2.5	43	46.66	11	6	21	37.32	7	4		
2.6	41	50.46	11	6	21	40.37	7	4		
2.7	40	54.42	10	5	20	43.53	6	3		
2.8	38	58.52	9	5	19	46.82	6	3		
2.9	37	62.78	9	5	18	50.23	5	3		
3	36	67.18	8	4	18	53.76	5	3		

$\frac{\alpha Le}{r_{xx}} > 180$

Loads not applicable to stainless steel, for stainless steel loads please consult the Technical Department for advice.

MS2115-C2

Combination comprising 2 no. MS2115

Finish: pre-galvanised = PG, post-galvanised = HDG

Section properties

Area cm ²	Wt kg/m	Ixx cm ⁴	Zxx (top) mm	Zxx (btm) mm	rxx cm	Iyy cm ⁴	Zyy cm ³	ryy mm
3.03	2.4	4.08	1.98	1.98	1.16	7.35	3.56	1.56

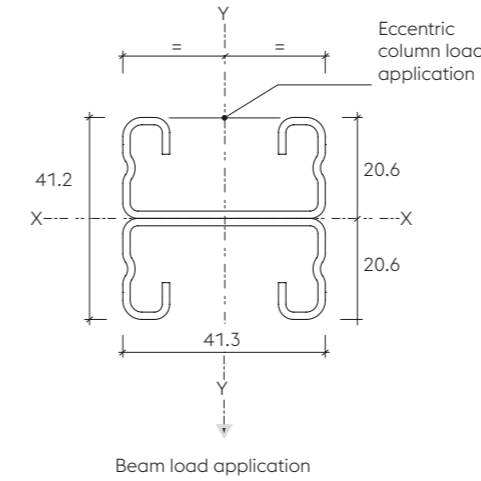

Safe load tables

Le (m)	Safe working loads in kg uniform		Def. limit span/200 (kg)	Def. limit span/360 (kg)	Safe working loads in kg concentrated		Def. limit span/200 (kg)	Def. limit span/360 (kg)	Safe column loads kg at centroid	Safe column loads kg at face
	(kg) Load	(mm) Def.			(kg) Load	(mm) Def.				
0.6	472	1.55	472	472	236	1.24	236	236	4938	1224
0.7	404	2.12	404	372	202	1.69	202	202	4729	1194
0.8	354	2.76	354	284	177	2.21	177	177	4458	1159
0.9	314	3.5	314	225	157	2.8	157	140	4117	1117
1	283	4.32	283	182	141	3.46	141	114	3725	1069
1.1	257	5.22	257	150	129	4.19	129	94	3319	1017
1.2	236	6.22	228	126	118	4.98	118	79	2934	963
1.3	218	7.3	194	108	109	5.84	109	67	2589	910
1.4	202	8.46	167	93	101	6.77	101	58	2290	859
1.5	189	9.71	146	81	94	7.77	91	51	2033	810
1.6	177	11.05	128	71	88	8.84	80	44	1813	763
1.7	166	12.48	113	63	83	9.98	71	39	1624	720
1.8	157	13.99	101	56	79	11.19	63	35	1463	679
1.9	149	15.59	91	50	74	12.47	57	32	1323	641
2	141	17.27	82	46	71	13.81	51	28	1202	606
2.1	135	19.04	74	41	67	15.23	46	26		
2.2	129	20.9	68	38	64	16.72	42	24		
2.3	123	22.84	62	34	62	18.27	39	22		
2.4	118	24.87	57	32	59	19.89	36	20		
2.5	113	26.98	52	29	57	21.59	33	18		
2.6	109	29.19	48	27	54	23.35	30	17		
2.7	105	31.47	45	25	52	25.18	28	16		
2.8	101	33.85	42	23	51	27.08	26	15		
2.9	98	36.31	39	22	49	29.04	24	14		
3	94	38.86	36	20	47	31.09	23	13		

$\frac{\alpha Le}{r_{yy}} > 180$

Loads not applicable to stainless steel, for stainless steel loads please consult the Technical Department for advice.



MS4125 – slotted

Finish: pre-galvanised = PG, post-galvanised = HDG

Section properties

Area cm ²	Wt kg/m	Ixx cm ⁴	Zxx (top) mm	Zxx (btm) mm	rxx cm	Iyy cm ⁴	Zyy cm ³	ryy mm
3.04	2.53	6.2	2.94	3.07	1.43	9.28	4.5	1.75

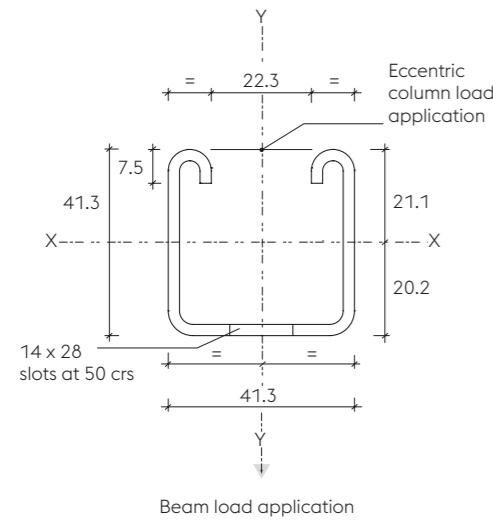

Safe load tables

Le (m)	Safe working loads in kg uniform		Def. limit span/200 (kg)	Def. limit span/360 (kg)	Safe working loads in kg concentrated		Def. limit span/200 (kg)	Def. limit span/360 (kg)	Safe column loads kg at centroid	Safe column loads kg at face
	(kg)	(mm)	(kg)	(kg)	(kg)	(mm)	(kg)	(kg)		
0.6	698	1.52	698	698	349	1.22	349	349	4541	1491
0.7	599	2.06	599	564	299	1.65	299	299	4151	1416
0.8	524	2.7	524	432	262	2.16	262	262	3701	1333
0.9	466	3.41	466	341	233	2.73	233	213	3250	1247
1	419	4.21	419	276	210	3.37	210	173	2842	1163
1.1	381	5.1	381	228	190	4.08	190	143	2521	1090
1.2	349	6.07	345	192	175	4.85	175	120	2229	1019
1.3	322	7.12	294	163	161	5.7	161	102	2011	960
1.4	299	8.26	254	141	150	6.6	150	88	1808	902
1.5	279	9.48	221	123	140	7.59	138	77	1637	849
1.6	262	10.78	194	108	131	8.63	121	67	1494	802
1.7	246	12.18	172	96	123	9.74	108	60	1391	767
1.8	233	13.65	153	85	116	10.92	96	53	1286	729
1.9	221	15.21	138	77	110	12.17	86	48	1196	695
2	210	16.86	124	69	105	13.48	78	43	1118	664
2.1	200	18.58	113	63	100	14.86	70	39		
2.2	190	20.39	103	57	95	16.32	64	36		
2.3	182	22.29	94	52	91	17.83	59	33		
2.4	175	24.27	86	48	87	19.42	54	30		
2.5	168	26.34	80	44	84	21.07	50	28		
2.6	161	28.49	74	41	81	22.78	46	26		
2.7	155	30.72	68	38	78	24.58	43	24		
2.8	150	33.04	63	35	75	26.43	40	22		
2.9	144	35.44	59	33	72	28.35	37	21		
3	140	37.92	55	31	70	30.37	35	19		

$\frac{\alpha Le}{r_{xx}} > 180$

Loads not applicable to stainless steel, for stainless steel loads please consult the Technical Department for advice.

MS4115 – slotted

Finish: pre-galvanised = PG, post-galvanised = HDG

Section properties

Area cm ²	Wt kg/m	Ixx cm ⁴	Zxx (top) mm	Zxx (btm) mm	rxx cm	Iyy cm ⁴	Zyy cm ³	ryy mm
1.93	1.61	4.25	2.01	2.1	1.48	6.1	2.96	1.78

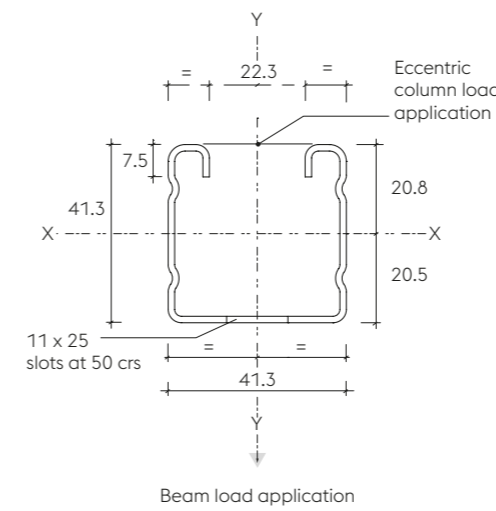

Safe load tables

Le (m)	Safe working loads in kg uniform		Def. limit span/200 (kg)	Def. limit span/360 (kg)	Safe working loads in kg concentrated		Def. limit span/200 (kg)	Def. limit span/360 (kg)	Safe column loads kg at centroid	Safe column loads kg at face
	(kg)	(mm)	(kg)	(kg)	(kg)	(mm)	(kg)	(kg)		
0.6	479	1.52	479	479	239	1.22	239	239	2930	1012
0.7	410	2.07	410	386	205	1.65	205	205	2691	961
0.8	359	2.7	359	296	180	2.16	180	180	2385	899
0.9	319	3.41	319	234	160	2.73	160	146	2082	836
1	287	4.21	287	189	144	3.37	144	118	1803	773
1.1	261	5.1	261	156	131	4.08	131	98	1564	714
1.2	239	6.07	237	131	120	4.81	120	82	1364	660
1.3	221	7.12	202	112	110	5.7	110	70	1199	611
1.4	205	8.26	174	97	103	6.6	103	60	1061	567
1.5	192	9.48	151	84	96	7.59	95	53	947	527
1.6	180	10.79	133	74	90	8.63	83	46	850	491
1.7	169	12.18	118	66	84	9.74	74	41	778	463
1.8	160	13.66	105	58	80	10.92	66	37	708	434
1.9	151	15.21	94	52	76	12.17	59	33		
2	144	16.86	85	47	72	13.49	53	30		
2.1	137	18.59	77	43	68	14.87	48	27		
2.2	131	20.4	70	39	65	16.32	44	24		
2.3	125	22.3	64	36	62	17.83	40	22		
2.4	120	24.28	59	33	60	19.42	37	21		
2.5	115	26.34	55	30	57	21.07	34	19		
2.6	110	28.49	50	28	55	22.8	32	18		
2.7	106	30.72	47	26	53	24.58	29	16		
2.8	103	33.04	43	24	51	26.43	27	15		
2.9	99	35.44	41	23	50	28.35	25	14		
3	96	37.93	38	21	48	30.35	24	13		

$\frac{\alpha Le}{r_{yy}} > 180$

Loads not applicable to stainless steel, for stainless steel loads please consult the Technical Department for advice.



CANTILEVER ARM DETAILS

Cantilever arms – single

Finish: post-galvanised as standard.

Ref	L (mm)	Wt (kg)
MS150A	150	0.77
MS300A	300	1.16
MS450A	450	1.56
MS600A	600	1.95
MS750A	750	2.35

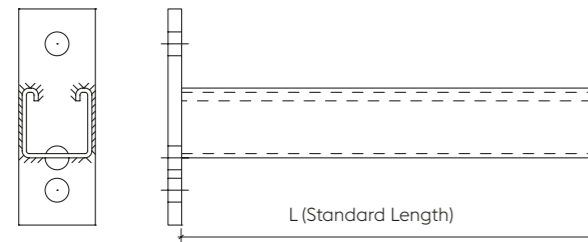

Recommended safe loads (kg) for arm bolted to 2.5mm thick channel (M12 bolt torque 65Nm)

X (m)	Total uniformly distributed load	Concentrated load
0.10	684	542
0.15	608	377
0.20	542	283
0.25	452	226
0.30	377	188
0.35	323	162
0.40	283	141
0.45	251	126
0.50	226	113
0.55	206	103
0.60	188	94
0.65	174	87
0.70	162	81
0.75	151	75

NB: Arms have been independently tested (M12 bolt torque 65 Nm). Tabulated safe loads satisfy minimum factor of safety of 3 on continuous slip and limited design stresses in channel arms and their fixings.

Loads not applicable to stainless steel, for stainless steel loads please consult the Technical Department for advice.

Cantilever arms – double

Finish: post-galvanised as standard.

Ref	L (mm)	Wt (kg)
MS150E	150	1.26
MS300E	300	2.05
MS450E	450	2.85
MS600E	600	3.64
MS750E	750	4.43

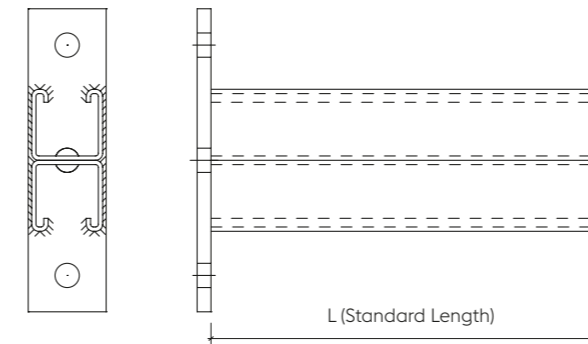

Recommended safe loads (kg) for arm bolted to 2.5mm thick channel (M12 bolt torque 65Nm)

X (m)	Total uniformly distributed load	Concentrated load
0.10	684	643
0.15	684	552
0.20	643	484
0.25	594	430
0.30	552	388
0.35	516	353
0.40	484	324
0.45	455	299
0.50	430	277
0.55	408	259
0.60	387	243
0.65	369	229
0.70	353	216
0.75	337	205

NB: Arms have been independently tested (M12 bolt torque 65 Nm). Tabulated safe loads satisfy minimum factor of safety of 3 on continuous slip and limited design stresses in channel arms and their fixings.

Loads not applicable to stainless steel, for stainless steel loads please consult the Technical Department for advice.

CHANNEL, FIXINGS AND ACCESSORIES

Channel – plain

Finish: pre-galvanised = PG, post-galvanised = HDG

Length m			Length m		
3	MS4125PG3		3	MS4115PG3	
6	MS4125PG6		6	MS4115PG6	
3	MS4125PG3C2		3	MS4115PG3C2	
6	MS4125PG6C2		6	MS4115PG6C2	
3	MS2125PG3		3	MS2115PG3	
6	MS2125PG6		6	MS2115PG6	
3	MS2125PG3C2		3	MS2115PG3C2	
6	MS2125PG6C2		6	MS2115PG6C2	



Channel – slotted

Finish: pre galvanised = PG, post galvanised = HDG, stainless steel grade 316 = SS

Length m			Slot sizes in channel	
3	MS4125PG3S11		S11 = 11 x 25mm	
6	MS4125PG6S11			
3	MS4125PG3S14		S14 = 14 x 28mm	
6	MS4125PG6S14			
3	MS2125PG3S11			
6	MS2125PG6S11			
3	MS2125PG3S14			
6	MS2125PG6S14			
3	MS4115PG3S11			
6	MS4115PG6S11			
3	MS2115PG3S11			
6	MS2115PG6S11			

Channel nuts

Finish: BZP as standard. For post-galvanised add HDG e.g. MPN06HDG.

Nut type	
Plain channel nuts	
MPN06	
MPN08	
MPN10	
MPN12	
Short spring channel nuts	
MSN06	
MSN08	
MSN10	
MSN12	
Long spring channel nuts	
MLN06	
MLN08	
MLN10	
MLN12	



Closure strip – 3m long

PVC white = W, PVC black = B, pre-galvanised steel = S

MS41CLW3	
MS41CLB3	
MS41CLS3	

PVC end caps

Black = B, White = W

41mm deep channel	
PVC41B	
PVC41W	
21mm deep channel	
PVC21B	
PVC21W	

BRACKETS



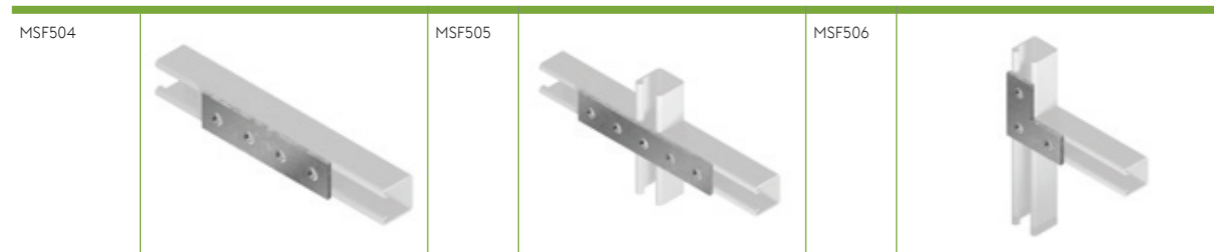





Finish: post-galvanised as standard.

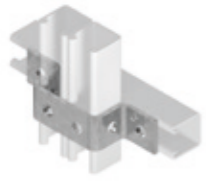

*Available in 7.5° increments from 15° to 82.5°

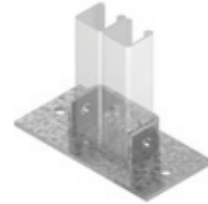
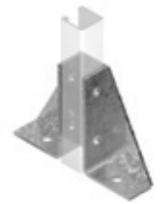
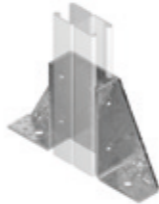

Finish: post-galvanised as standard. For stainless steel grade 1.4404 (316L) add SS e.g. MSF501/06SS

MSU803		MSU804		MSU805	
MSU806		MSU807		MSU808	
MSU809		MBP304		MBP305	
MBP306		MBP307		MBP308	

MBC400		MBC401CP		MBC402CP	
SWL 270kg		SWL 230kg		SWL 200kg	
MBC403CP		MBC404CP		MBC405/65	
SWL 200kg		SWL 220kg		SWL 450kg	
MBC405/110		MBC405/150		MBC407	
SWL 450kg		SWL 450kg		SWL 220kg	
MBC408		<p>Holes in brackets are 14mm in diameter for M12 hexagonal head bolts</p> <p>Beam clamps should be used in pairs. Maximum loadings given are per clamp when used in pairs.</p> <p>Where required, cone point screws included.</p>			
SWL 220kg					

FASTENERS

Hexagon head set screws

BZP finish as standard – sold in packs of 100

Size	
M6 x 20	M06x20HS
M6 x 25	M06x25HS
M8 x 20	M08x20HS
M8 x 25	M08x25HS
M10 x 20	M10x20HS
M10 x 25	M10x25HS
M12 x 20	M12x20HS
M12 x 25	M12x25HS



Cone point set screws

BZP finish as standard – sold in packs of 100

Size	
M10 x 40	M10x40CP



Flat washers

BZP finish as standard – sold in packs of 100

Size	
M06	M06FW
M08	M08FW
M10	M10FW
M12	M12FW



Penny washers

BZP finish as standard – sold in packs of 100

Size	
M06	M06PW
M08	M08PW
M10	M10PW
M12	M12PW



Threaded rod x 3m long

BZP finish as standard

Size	
M06	M06x3TR
M08	M08x3TR
M10	M10x3TR



Purlin clip

BZP finish as standard

Size	
M10	M10PC

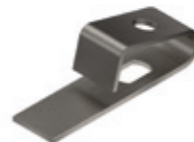

Roofing bolt and nut

BZP finish as standard – sold in packs of 100

Size	
M6 x 12	M06x12RB
M6 x 25	M06x25RB



Hexagon nuts

BZP finish as standard – sold in packs of 100

Size	
M06	M06HN
M08	M08HN
M10	M10HN
M12	M12HN

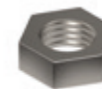

Lock washers

BZP finish as standard – sold in packs of 100

Size	
M06	M06LW
M08	M08LW
M10	M10LW
M12	M12LW



Eye bolts

BZP finish as standard – sold in packs of 100

Size	
M06 x 80	M06x80EB
M08 x 80	M08x80EB
M10 x 80	M10x80EB
M12 x 80	M12x80EB



Rod connector

BZP finish as standard

Size	
M06	M06RC
M08	M08RC
M10	M10RC
M12	M12RC



Flange clamp

BZP finish as standard

Size	
M10	M10FC
M12	M12FC



PRE-FABRICATION

Pre-fabrication not only reduces waste and contributes to site safety, but also provides cost effective solutions manufactured to factory tolerances.

Metsec offers a comprehensive pre-fabrication service ranging from simple cut lengths of channel to complex frames and brackets.

Cut-to-length service

Dedicated machine time is allowed daily for 41 x 41mm channel for pre-galvanised, post-galvanised and stainless steel finishes.

The Metsec sales office produces Kanbans and the work is scheduled at the point of order without the need to consult with production.

Other channel sizes can be scheduled into normal production cycles.

Pre-fabricated frames

Both flat frames and three dimensional frames can be prefabricated in either all bolted or all welded construction. Part bolted and part welded frames can also be accommodated, particularly when parts need to be removed to allow access for cable runs.

Metsec can also build in cable tray, cable ladder and cable trunking within the frames for a complete modular solution.

Pre-fabrication offsite allows the work to be produced to factory tolerances with little to no waste leaving sites uncluttered and a safer environment.

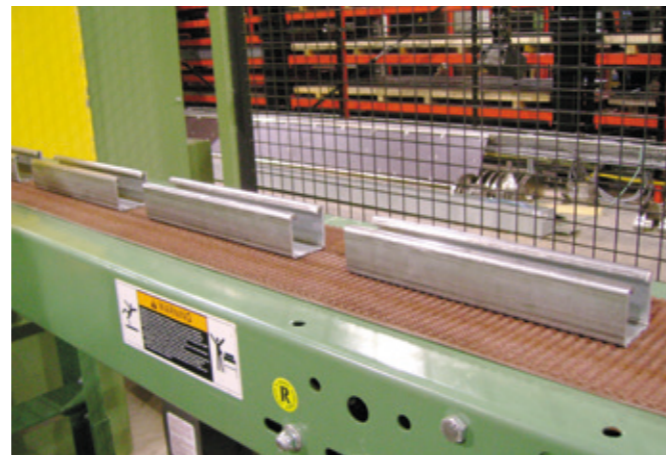

Optimising design and assembly

By providing basic drawings, M & E contractors can benefit from Metsec's expertise in determining where support systems can be pre-fabricated. This is then converted to a CAD drawing identifying areas that can be provided as a frame, with the balance in cut lengths to complete the kit.

Once an order is placed, Metsec will attend a pre-commencement meeting to schedule the delivery requirements and agree any outstanding technical details, including vehicle restrictions and packing requirements.

For bolted frames, all connections are torqued to the appropriate level and passed off by the quality department.

Less complex assemblies can be supplied against an approved drawing for manufacture and delivered against a call off order scheduled to meet the project requirements. This can be particularly advantageous when there are space restrictions on site for both storage and installation.

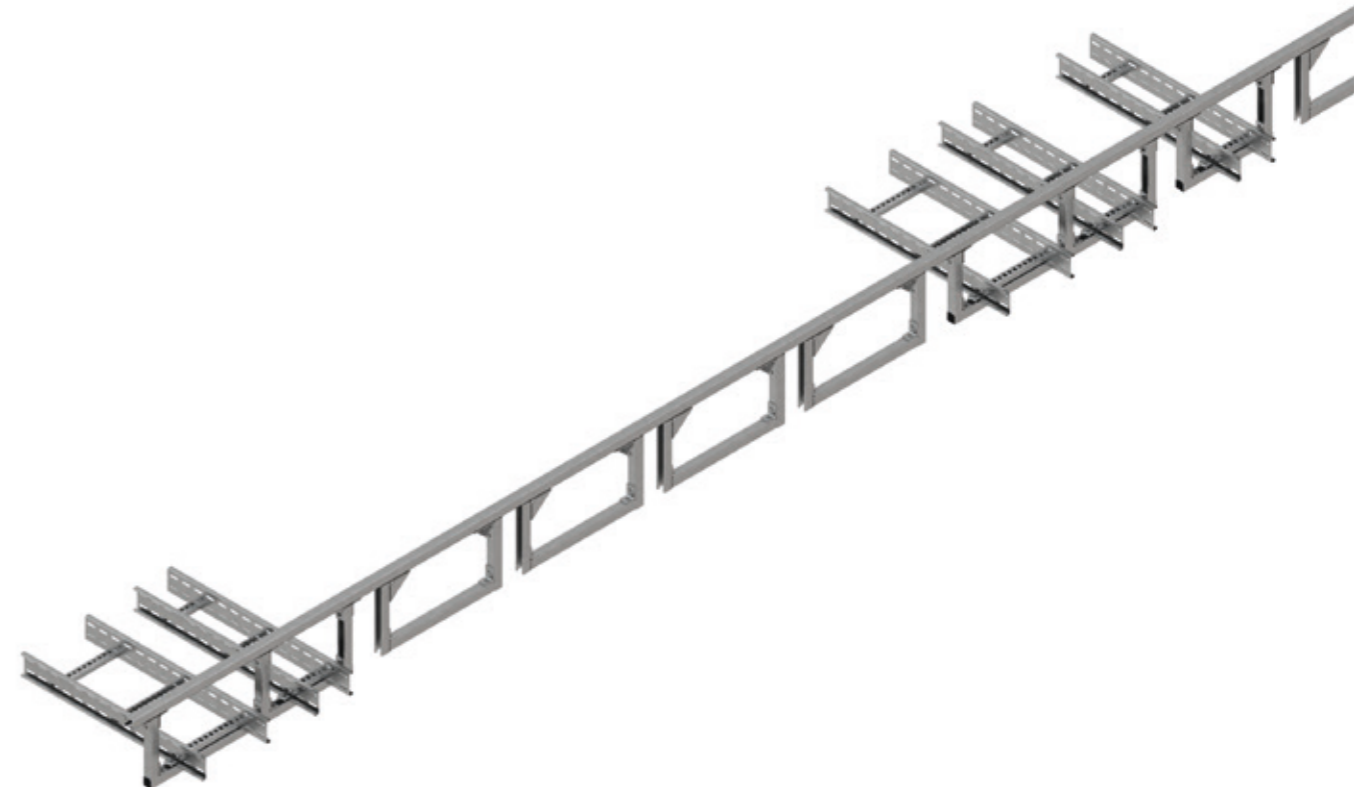
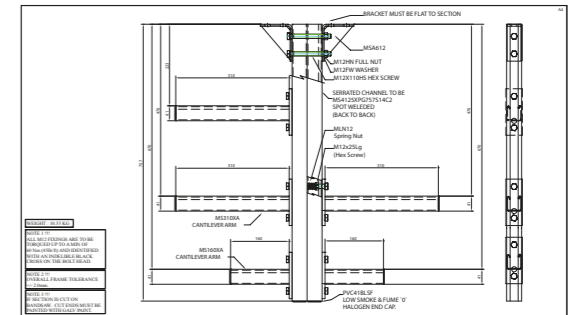
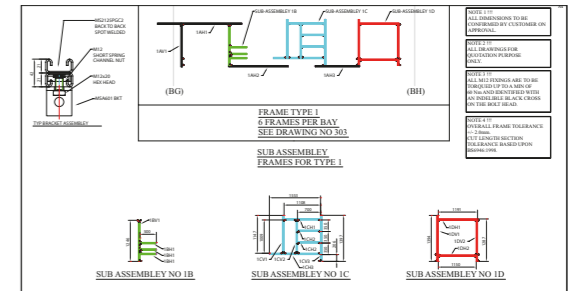
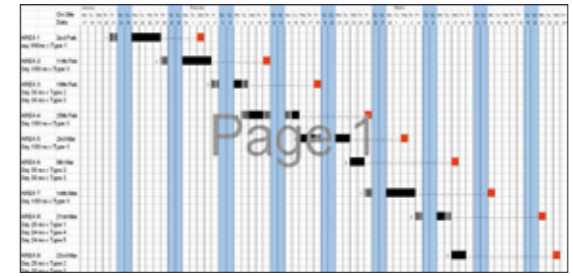

Cable Management
Tel: +44(0) 121 601 6085
metsec.cablemanagement@voestalpine.com

Cable Management Technical Department
Tel: +44(0) 121 601 6030
Metsec.CMDTechnical@voestalpine.com

© Copyright voestalpine Metsec plc 2024

In the interests of a policy of continuous research and development, voestalpine Metsec plc reserve the right to change the specifications in this publication without prior notice.

voestalpine Metsec plc

Broadwell Road, Oldbury, West Midlands, B69 4HF
Tel: +44 (0) 121 601 6000
email: metsec.plc@voestalpine.com

www.metsec.com

voestalpine

ONE STEP AHEAD.

